

The CENTRE for EDUCATION
in MATHEMATICS and COMPUTING

Problem of the Week Problems and Solutions 2022 - 2023

Problem E (Grade 11/12)

Themes

(Click on a theme name to jump to that section.)

Number Sense (N)

Geometry & Measurement (G)

Algebra (A)

Data Management (D)

Computational Thinking (C)

The problems in this booklet are organized into themes.

A problem often appears in multiple themes.

Number Sense (N)





Problem of the Week

Problem E

Three Items Only

Three-Item-Menu is a restaurant that sells only hamburgers, french fries, and soft drinks.

One day, exactly 120 customers made a purchase. Half of the customers purchased at least a hamburger, $\frac{1}{4}$ of the customers purchased at least french fries, but $\frac{1}{3}$ of the customers purchased only a soft drink. Of the customers who bought a hamburger, $\frac{4}{5}$ of them bought at least one other item.

How many customers purchased a hamburger and soft drink but not french fries?

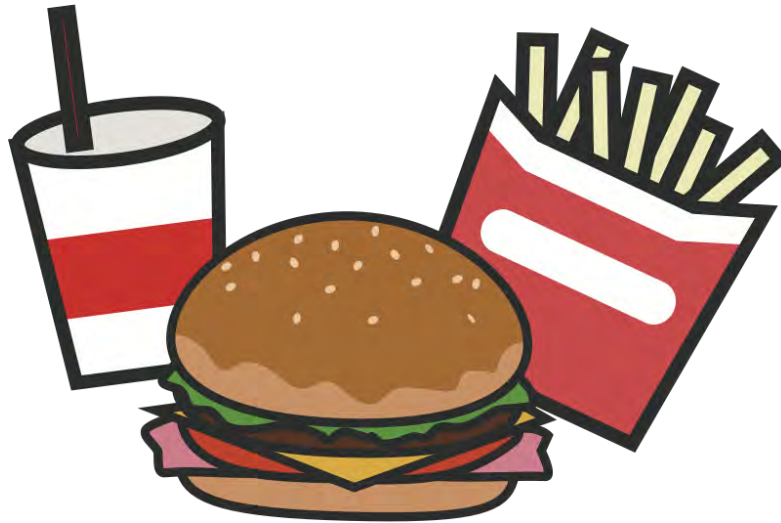



Problem of the Week

Problem E and Solution

Three Items Only

Problem

Three-Item-Menu is a restaurant that sells only hamburgers, french fries, and soft drinks.

One day, exactly 120 customers made a purchase. Half of the customers purchased at least a hamburger, $\frac{1}{4}$ of the customers purchased at least french fries, but $\frac{1}{3}$ of the customers purchased only a soft drink. Of the customers who bought a hamburger, $\frac{4}{5}$ of them bought at least one other item.

How many customers purchased a hamburger and soft drink but not french fries?

Solution

We start by defining seven variables as follows:

- Let a be the number of customers who purchased a hamburger only.
- Let b be the number of customers who purchased french fries only.
- Let c be the number of customers who purchased a soft drink only.
- Let d be the number of customers who purchased a hamburger and french fries but not a soft drink.
- Let k be the number of customers who purchased french fries and a soft drink but not a hamburger.
- Let m be the number of customers who purchased a hamburger and a soft drink but not french fries.
- Let n be the number of customers who purchased a hamburger, french fries and a soft drink.

We have added these variables to the Venn diagram below. We need to determine the value of m .

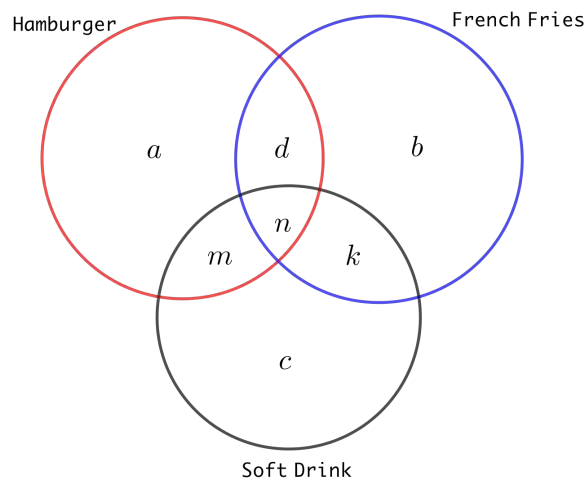



We know that 120 customers made a purchase, so

$$a + b + c + d + k + m + n = 120 \quad (1)$$

We are given that half of the customers purchased a hamburger, so $\frac{1}{2} \times 120 = 60$ customers purchased a hamburger. These customers may have also purchased french fries or a soft drink or both or neither. This tells us that

$$a + d + m + n = 60 \quad (2)$$

We are given that $\frac{1}{4}$ of the customers purchased french fries, so $\frac{1}{4} \times 120 = 30$ customers purchased french fries. These customers may have also purchased a hamburger or a soft drink or both or neither. This tells us that

$$b + d + k + n = 30 \quad (3)$$

We are given that $\frac{1}{3}$ of the customers purchased only a soft drink, so $\frac{1}{3} \times 120 = 40$ customers purchased only a soft drink. Therefore, $c = 40$.

We are given that, of the customers who bought a hamburger, $\frac{4}{5}$ bought at least one other item. So, $\frac{4}{5}$ of the 60 customers who purchased a hamburger bought at least one other item. In other words, $\frac{4}{5} \times 60 = 48$ also bought french fries, a soft drink or both. Therefore,

$$d + m + n = 48 \quad (4)$$

Subtracting equation (4) from equation (2), we see that $a = 12$.

Substituting $a = 12$ and $c = 40$ into equation (1), we have $12 + b + 40 + d + k + m + n = 120$, and thus $b + d + k + m + n = 68$, or $(b + d + k + n) + m = 68$. From equation (3) we know $b + d + k + n = 30$, and so $30 + m = 68$, thus $m = 38$. Therefore, 38 customers purchased a hamburger and soft drink but not french fries.

We have determined what was required and can stop here. We do not need to solve for the remaining variables. It actually turns out that in this problem there is not enough information given to determine the values of all of the remaining variables.



Problem of the Week

Problem E

A Rectangle and a Square

Simeon has a rope that is 108 cm long and is asked to cut the rope once so that one of the pieces can be arranged, with its two ends touching, to form a square, and the other piece can be arranged, with its two ends touching, to form a rectangle with one side length of 6 cm. Furthermore, the area of the square will be equal to the area of the rectangle.

Where should Simeon make the cut to the original piece of rope?

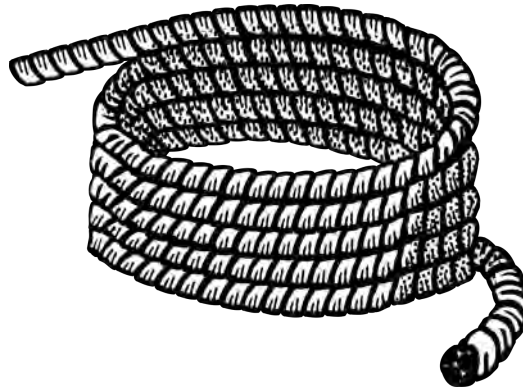

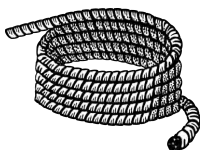

Problem of the Week

Problem E and Solution

A Rectangle and a Square

Problem

Simeon has a rope that is 108 cm long and is asked to cut the rope once so that one of the pieces can be arranged, with its two ends touching, to form a square, and the other piece can be arranged, with its two ends touching, to form a rectangle with one side length of 6 cm. Furthermore, the area of the square will be equal to the area of the rectangle.

Where should Simeon make the cut to the original piece of rope?

Solution

Let the length of the piece of rope used to form the square be $4x$ cm. This is also equal to the perimeter of the square. Then the side length of the square is $4x \div 4 = x$ cm. The area of the square is

$$x \times x = x^2 \text{ cm}^2 \quad (1)$$

The length of the piece of rope used to form the rectangle is $(108 - 4x)$ cm. This is also equal to the perimeter of the rectangle. If one side length of the rectangle is 6 cm, then there is $108 - 4x - 6 - 6 = (96 - 4x)$ cm left to form the lengths of the two other sides of the rectangle. Therefore, the other side length of the rectangle is $\frac{96-4x}{2} = (48 - 2x)$ cm. Thus, the area of the rectangle is

$$(6)(48 - 2x) = (288 - 12x) \text{ cm}^2 \quad (2)$$

We are given that the area of the square is equal to the area of the rectangle. So, by equating equations (1) and (2), we obtain

$$\begin{aligned} x^2 &= 288 - 12x \\ x^2 + 12x - 288 &= 0 \\ (x - 12)(x + 24) &= 0 \end{aligned}$$

Thus, $x = 12$ or $x = -24$. Since x is the length of the side of the square, we must have $x > 0$. Therefore, $x = 12$ cm. Then the length of rope used to form the square is $4x = 4(12) = 48$ cm.

Therefore, the cut should be made 48 cm from one end (and so 60 cm from the other end), creating a 60 cm piece for the rectangle and a 48 cm piece for the square.

NOTE:

The area of the square is $12 \times 12 = 144 \text{ cm}^2$.

The length of the other side of the rectangle is $48 - 2x = 48 - 24 = 24$ cm. The area of the rectangle is $24 \times 6 = 144 \text{ cm}^2$.

(These calculations were not required but are provided as a check of the correctness of the result.)



Problem of the Week

Problem E

How Many?

Natalia has a jar containing some number magnets. In the jar there is one set of numbers from 1 to 9, as well as some extra number 5 magnets and number 8 magnets. If the mean (average) of all the numbers in the jar is 6.4, what is the smallest possible number of number magnets in the jar?





Problem of the Week

Problem E and Solution

How Many?

Problem

Natalia has a jar containing some number magnets. In the jar there is one set of numbers from 1 to 9, as well as some extra number 5 magnets and number 8 magnets. If the mean (average) of all the numbers in the jar is 6.4, what is the smallest possible number of number magnets in the jar?

Solution

Let m be the number of extra number 5 magnets and n be the number of extra number 8 magnets in the jar, where both m and n are positive integers.

It follows that there are a total of $(9 + m + n)$ number magnets in the jar. The sum of the numbers in the jar is $(1 + 2 + 3 + \cdots + 7 + 8 + 9 + 5m + 8n)$ which simplifies to $(45 + 5m + 8n)$.

The mean (average) of a set of values is equal to the sum of the values in the set divided by the number of values in the set. Since the average of all the numbers in the jar is 6.4, we can write the following equation.

$$\begin{aligned}\frac{45 + 5m + 8n}{9 + m + n} &= 6.4 \\ \frac{450 + 50m + 80n}{9 + m + n} &= 64 \\ 450 + 50m + 80n &= 64(9 + m + n) \\ 450 + 50m + 80n &= 576 + 64m + 64n \\ 16n - 14m &= 126 \\ 8n &= 63 + 7m \\ n &= \frac{7(9 + m)}{8}\end{aligned}$$

Since m and n are positive integers, $7(9 + m)$ must be divisible by 8. Since 7 is not a multiple of 8, it follows that $(9 + m)$ must be a multiple of 8.

Since m is a positive integer, $(9 + m)$ must be greater than 9. The smallest multiple of 8 which is also greater than 9 is 16. Therefore, $9 + m = 16$ and $m = 7$. Then we can solve for n .

$$n = \frac{7(9 + m)}{8} = \frac{7(16)}{8} = 14$$

Therefore, the smallest number of number magnets in the jar is $9 + 7 + 14 = 30$. It is left as an exercise for the solver to verify that this produces the correct average.

EXTENSION:

Determine the *largest* number of number magnets less than 1000 that could be in the jar, if their mean is 6.4.



Problem of the Week

Problem E

Two Digits at a Time

The number 34 692 contains 5 digits, and so we say its digit length is 5. The first digit of 34 692 is 3. Also, the two-digit integers formed by choosing any pair of consecutive digits, that is, 34, 46, 69, and 92, are all divisible by either 17 or 23.

An integer with digit length 2022 has first digit 3. This integer also has the property that the two-digit integers formed by choosing any pair of consecutive digits are all divisible by either 17 or 23.

List all of the possibilities for the last three digits of this integer.

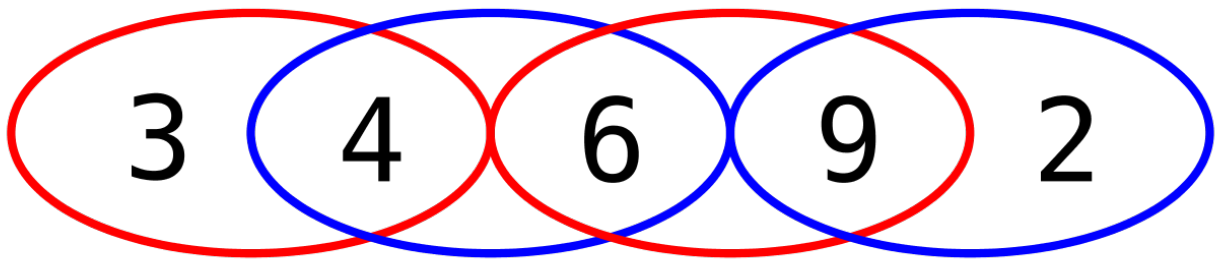

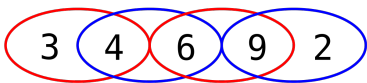

Problem of the Week

Problem E and Solution

Two Digits at a Time

Problem

The number 34692 contains 5 digits, and so we say its digit length is 5. The first digit of 34692 is 3. Also, the two-digit integers formed by choosing any pair of consecutive digits, that is, 34, 46, 69, and 92, are all divisible by either 17 or 23.

An integer with digit length 2022 has first digit 3. This integer also has the property that the two-digit integers formed by choosing any pair of consecutive digits are all divisible by either 17 or 23.

List all of the possibilities for the last three digits of this integer.

Solution

We first list out all two-digit multiples of 17 and 23.

The two-digit multiples of 17 are 17, 34, 51, 68, and 85.

The two-digit multiples of 23 are 23, 46, 69, and 92.

Since the integer starts with a 3 and the only two-digit number in the two lists that starts with a 3 is 34, the second digit must be 4. Similarly, the third digit is 6, since the only two-digit number in the two lists starting with a 4 is 46. However, the fourth digit can be 8 or 9, since there are two two-digit numbers, 68 and 69, in the two lists that start with a 6. Now we need to consider two cases.

- Case 1: The fourth digit is an 8.

Since the only two-digit number in the two lists starting with an 8 is 85, the fifth digit must then be 5. Similarly, the sixth digit is 1, and the seventh digit is 7. We must stop here, since there is no two-digit number in either list that starts with a 7. Therefore, the fourth digit must not be 8.

- Case 2: The fourth digit is 9.

Since the only two-digit number in the two lists starting with a 9 is 92, the fifth digit must then be 2. Similarly, the sixth digit is 3. We can now repeat our argument from the beginning. The digit after the 3 must be a 4, then a 6, then a 9, then a 2. The five digits '34692' will continue to repeat as long as a 9 follows the 6.

Since $2022 \div 5 = 404.4$, the number of length 2022 will consist of 404 blocks of five digits followed by two more digits. As we saw above, the first 403 blocks of digits must each be the five digits 34692. However, the last seven digits could be 3469234 or 3468517.

Therefore, there are two possibilities for the last three digits. The last three digits could be 234 or 517.



Problem of the Week

Problem E

All Square

The positive multiples of 3 from 3 to 2400, inclusive, are each multiplied by the same positive integer, n . All of the products are then added together and the resulting sum is a perfect square.

Determine the value of the smallest positive integer n that makes this true.

$$3, 6, 9, \dots, 2400$$

NOTE:

In solving this problem, it may be helpful to use the fact that the sum of the first n positive integers is equal to $\frac{n(n+1)}{2}$.

That is,

$$1 + 2 + 3 + \dots + n = \frac{n(n+1)}{2}$$

For example, $1 + 2 + 3 + 4 + 5 = 15$, and $\frac{5(6)}{2} = 15$.

Also, $1 + 2 + 3 + 4 + 5 + 6 + 7 + 8 = 36$, and $\frac{8(9)}{2} = 36$.



Problem of the Week

3, 6, 9, . . . , 2400

Problem E and Solution

All Square

Problem

The positive multiples of 3 from 3 to 2400, inclusive, are each multiplied by the same positive integer, n . All of the products are then added together and the resulting sum is a perfect square.

Determine the value of the smallest positive integer n that makes this true.

Solution

What does the prime factorization of a perfect square look like? Let's look at a few examples: $9 = 3^2$, $36 = 6^2 = 2^2 3^2$, and $129\,600 = 360^2 = 2^6 3^4 5^2$. Notice that the exponent on each of the prime factors in the prime factorization in each of the three examples is an even number. In fact, a positive integer is a perfect square exactly when the exponent on each prime in its prime factorization is even. Can you convince yourself that this is true?

The positive integer n is the smallest positive integer such that

$$3n + 6n + 9n + \cdots + 2394n + 2397n + 2400n \quad (1)$$

is a perfect square.

Factoring expression (1), we obtain

$$3n(1 + 2 + 3 + \cdots + 798 + 799 + 800)$$

Then, using the formula $1 + 2 + 3 + \cdots + n = \frac{n(n+1)}{2}$, with $n = 800$, we see that this expression is equal to

$$3n \left(\frac{800 \times 801}{2} \right) = 3n(400)(801)$$

Factoring $3 \times 400 \times 801$ into the product of primes, we have that expression (1) is equal to

$$3n[(2)(2)(2)(2)(5)(5)][(3)(3)(89)] = n(2^4)(5^2)(3^3)(89) \quad (2)$$

We need to determine what additional factors are required to make the quantity in expression (2) a perfect square such that n is as small as possible. In order for the exponent on each prime in the prime factorization to be even, we need n to be $3 \times 89 = 267$. Then the quantity in expression (2) is the perfect square

$$n(2^4)(5^2)(3^3)(89) = (3)(89)(2^4)(5^2)(3^3)(89) = (2^4)(5^2)(3^4)(89^2) = [(2^2)(5)(3^2)(89)]^2$$

Therefore, the smallest positive integer is 267 and the perfect square is

$$267 \times 3 \times 400 \times 801 = 256\,640\,400 = (16\,020)^2$$



NOTE: When solving this problem, we could have instead noticed that $3n + 6n + 9n + \cdots + 2400n$ is an arithmetic series with $t_1 = 3n$ and $t_{800} = 2400n$.

Substituting these values for t_1 and t_{800} into the formula for the sum of the terms in an arithmetic series, we get

$$S_{800} = \frac{800}{2} (3n + 2400n) = 400(2403n)$$

When we factor $400(2403n)$ into the product of primes, we get the same expression as (2), and then we can continue from there to get the solution of 267.



Problem of the Week

Problem E

Coffee Sales

For the months of April, May and June, *Coffee Only* sold coffee for \$2.50 per cup.

In May, they sold $y\%$ more cups of coffee than in April, where $y \geq 0$. In June, they sold $y\%$ fewer cups of coffee than in May.

Their records for sales in May were misplaced. They sold \$31 250 worth of coffee in April. In June they sold \$30 800 worth of coffee.

Determine the total value of the coffee they sold in May.





Problem of the Week

Problem E and Solution

Coffee Sales

Problem

For the months of April, May and June, *Coffee Only* sold coffee for \$2.50 per cup.

In May, they sold $y\%$ more cups of coffee than in April, where $y \geq 0$. In June, they sold $y\%$ fewer cups of coffee than in May.

Their records for sales in May were misplaced. They sold \$31 250 worth of coffee in April. In June they sold \$30 800 worth of coffee.

Determine the total value of the coffee they sold in May.

Solution

Since the company had sales of \$31 250 in April, the amount of coffee sold in April was $\frac{31250}{2.50} = 12\,500$ cups.

Since the company had sales of \$30 800 in June, the amount of coffee sold in June was $\frac{30800}{2.50} = 12\,320$ cups.

In May, *Coffee Only* sold $y\%$ more cups of coffee than in April. In other words, they sold

$$12\,500 + 12\,500 \left(\frac{y}{100} \right) = 12\,500 \left(1 + \frac{y}{100} \right)$$

cups of coffee in May.

In June, they sold $y\%$ fewer cups of coffee than in May. In other words, they sold

$$\left[12\,500 \left(1 + \frac{y}{100} \right) \right] - \left[12\,500 \left(1 + \frac{y}{100} \right) \right] \left(\frac{y}{100} \right) = \left[12\,500 \left(1 + \frac{y}{100} \right) \right] \left(1 - \frac{y}{100} \right)$$

cups of coffee in June.

We also know that *Coffee Only* sold 12 320 cups of coffee in June. Therefore,

$$\begin{aligned} 12\,500 \left(1 + \frac{y}{100} \right) \left(1 - \frac{y}{100} \right) &= 12\,320 \\ \left(1 + \frac{y}{100} \right) \left(1 - \frac{y}{100} \right) &= \frac{616}{625} \\ 1 - \frac{y^2}{10\,000} &= \frac{616}{625} \\ \frac{y^2}{10\,000} &= \frac{9}{625} \\ y^2 &= 144 \end{aligned}$$

Since $y \geq 0$, we have $y = 12$. Therefore, in May *Coffee Only* sold

$$12\,500 \left(1 + \frac{y}{100} \right) = 12\,500 \left(1 + \frac{12}{100} \right) = 14\,000$$

cups of coffee. The total value of the coffee sold in May was $14\,000 \times \$2.50 = \$35\,000$.



Problem of the Week

Problem E

Secret Numbers

Wakana, Yousef, and Zora are each given a card with a positive integer on it. They cannot see each other's cards, but are told that the sum of their three numbers is 14. They then make the following observations.

- Wakana says "I know that Yousef and Zora have different numbers."
- Yousef then says "I already knew that all three numbers were different."
- Zora then says "I now know what all three of the numbers are."

What number does each person have?





Problem of the Week

Problem E and Solution

Secret Numbers

Problem

Wakana, Yousef, and Zora are each given a card with a positive integer on it. They cannot see each other's cards, but are told that the sum of their three numbers is 14. They then make the following observations.

- Wakana says "I know that Yousef and Zora have different numbers."
- Yousef then says "I already knew that all three numbers were different."
- Zora then says "I now know what all three of the numbers are."

What number does each person have?

Solution

We want to find the single solution to the problem $x + y + z = 14$ that satisfies the observations made by Wakana, Yousef, and Zora. It turns out that there are 78 different possible sums of three positive integers totalling 14. We could list all of the possible solutions and then proceed through the observations until we determine the required solution. However, our approach will be far less exhausting. At the end of the solution, we will provide a justification as to why there are 78 positive integer solutions to the equation $x + y + z = 14$.

The sum of the three numbers is 14, an even number. To generate an even sum, the three numbers must all be even, or one of the numbers must be even and the other two numbers must be odd. We will go through each of the three observations to determine the three numbers.

- First, Wakana says "I know that Yousef and Zora have different numbers."

How can Wakana KNOW? If her number is even, then Yousef and Zora could both have even numbers or both have odd numbers to generate the sum 14. So if her number was even, Wakana would not KNOW that the other two numbers were different. Therefore, Wakana must have an odd number, one of the others has an odd number and the other has an even number.

- Then, Yousef says "I already knew that all three numbers were different."

Using the same logic as before, since Yousef knows Wakana and Zora have different numbers, Yousef must have an odd number (and thus Zora must have the even number). But how does Yousef KNOW that all three numbers are different?

If Yousef has a 1, 3, or 5, Wakana could have the same number, since $1 + 1 + 12$, $3 + 3 + 8$, and $5 + 5 + 4$ all equal 14. So Yousef cannot have a 1, 3, or 5.

If Yousef has a 7, 9, 11, or 13, Wakana could not have the same number as Yousef, in order for the three numbers to sum to 14. Furthermore, if Yousef has a 7, Wakana must have a 5 or lower. If Yousef has a 9, Wakana must have a 3 or lower. If Yousef has an 11, Wakana must have a 1. Yousef cannot have a 13, since the three numbers to sum to 14.



At this point our list of possible solutions has dropped from 78 to 6. The remaining possibilities are shown in the table.

Yousef's Number	Wakana's Number	Zora's Number
7	1	6
7	3	4
7	5	2
9	1	4
9	3	2
11	1	2

- Finally, Zora says “I now know what all three of the numbers are.”

If Zora has a 2, Yousef could have a 7 and Wakana could have a 5, or Yousef could have a 9 and Wakana could have a 3, or Yousef could have an 11 and Wakana could have a 1. So Zora cannot have a 2.

If Zora has a 4, Yousef could have a 7 and Wakana could have a 3, or Yousef could have a 9 and Wakana could have a 1. So Zora cannot have a 4.

However, if Zora has a 6, then Yousef must have a 7 and Wakana must have a 1. This is the only possibility in which Zora's statement is true.

Therefore, Wakana has a 1, Yousef has a 7, and Zora has a 6.

NOTE: We will show here why there are 78 solutions to the equation $x + y + z = 14$, where x , y , and z are positive integers.

Suppose $x = 1$. Then we have the following possibilities for y and z .

y	1	2	3	4	5	6	7	8	9	10	11	12
z	12	11	10	9	8	7	6	5	4	3	2	1

In total, there are 12 positive integer solutions when $x = 1$.

Suppose $x = 2$. Then we have the following possibilities for y and z .

y	1	2	3	4	5	6	7	8	9	10	11
z	11	10	9	8	7	6	5	4	3	2	1

In total, there are 11 positive integer solutions when $x = 2$.

Continuing in this manner, we can find that there are 10 positive integer solutions when $x = 3$, 9 positive integer solutions when $x = 4$, 8 positive integer solutions when $x = 5$, 7 positive integer solutions when $x = 6$, 6 positive integer solutions when $x = 7$, 5 positive integer solutions when $x = 8$, 4 positive integer solutions when $x = 9$, 3 positive integer solutions when $x = 10$, 2 positive integer solutions when $x = 11$, and 1 positive integer solution when $x = 12$.

In total, there are

$$12 + 11 + 10 + 9 + 8 + 7 + 6 + 5 + 4 + 3 + 2 + 1 = 78$$

positive integer solutions to $x + y + z = 14$.



Problem of the Week

Problem E

Not Again

When $\frac{1}{50^{2023}}$ is written as a decimal, it terminates.

What is the last non-zero digit in the decimal representation of $\frac{1}{50^{2023}}$?

$$\frac{1}{50^{2023}} = \dots\dots\dots$$





$$\frac{1}{50^{2023}} = \dots\dots\dots$$

Problem of the Week

Problem E and Solution

Not Again

Problem

When $\frac{1}{50^{2023}}$ is written as a decimal, it terminates.

What is the last non-zero digit in the decimal representation of $\frac{1}{50^{2023}}$?

Solution

Our first instinct might be to use our calculator to get an idea of how the last digit behaves for the first few powers of $\frac{1}{50}$. This might work for a little while, however most calculators let us down too quickly.

Notice that $\frac{1}{50^{2023}} = \left(\frac{1}{50}\right)^{2023} = \left(\frac{1}{100} \times 2\right)^{2023} = (0.01 \times 2)^{2023} = (0.01)^{2023} \times 2^{2023}$.

The last non-zero digit in the decimal representation of $\frac{1}{50^{2023}}$ will therefore be the last non-zero digit in the decimal representation of $(0.01)^{2023}$ multiplied by the last digit of 2^{2023} .

Since the last non-zero digit in the decimal representation of $(0.01)^{2023}$ is 1, the last non-zero digit in the decimal representation of $\frac{1}{50^{2023}}$ will therefore be the last digit of 2^{2023} .

We now examine the last digit of various powers of 2:

$$\begin{array}{cccc} 2^1 = \mathbf{2} & 2^2 = \mathbf{4} & 2^3 = \mathbf{8} & 2^4 = \mathbf{16} \\ 2^5 = \mathbf{32} & 2^6 = \mathbf{64} & 2^7 = \mathbf{128} & 2^8 = \mathbf{256} \end{array}$$

Notice that the last digit repeats every four powers of 2. It is 2, then 4, then 8, then 6. This pattern continues, and we can verify that 2^9 ends with a 2, 2^{10} ends with a 4, 2^{11} ends with an 8, 2^{12} ends with a 6, and so on. We will leave it up to the solver to explain *why* this pattern continues.

Now we need to determine the number of complete cycles of this pattern before we get to 2^{2023} . Since $\frac{2023}{4} = 505\frac{3}{4}$, it follows that there are there are 505 complete cycles. Since $505 \times 4 = 2020$, this means 2^{2020} ends with a 6, 2^{2021} ends with a 2, 2^{2022} ends with a 4, and 2^{2023} ends with an 8.

Since 2^{2023} ends with an 8, $\frac{1}{50^{2023}}$ also ends with an 8.



Problem of the Week

Problem E

Across the Prism

A trapezoidal prism is a prism in which opposite parallel ends are congruent trapezoids.

For the trapezoidal prism shown, the opposite parallel sides of each trapezoid are 36 cm and 16 cm in length. The non-parallel sides of each trapezoid are 16 cm and 12 cm in length. The prism is 40 cm long. The volume of the prism is 9984 cm^3 .

A body diagonal of a prism is a line connecting two vertices that are not on the same face. Find the length of the body diagonal AB (indicated in the diagram), accurate to 1 decimal place.

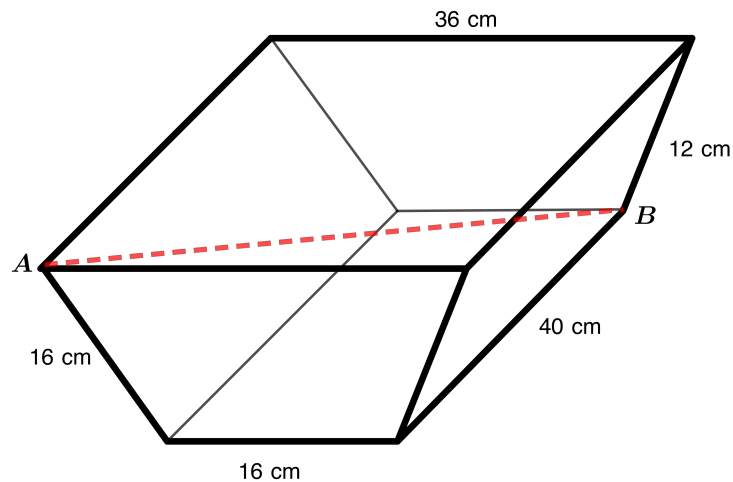

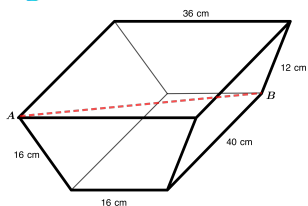

Problem of the Week Problem E and Solution Across the Prism

Problem

A trapezoidal prism is a prism in which opposite parallel ends are congruent trapezoids.

For the trapezoidal prism shown, the opposite parallel sides of each trapezoid are 36 cm and 16 cm in length. The non-parallel sides of each trapezoid are 16 cm and 12 cm in length. The prism is 40 cm long. The volume of the prism is 9984 cm^3 .

A body diagonal of a prism is a line connecting two vertices that are not on the same face. Find the length of the body diagonal AB (indicated in the diagram), accurate to 1 decimal place.

Solution

Let h represent the height of the trapezoid. We will determine the height using two different methods.

Method 1: Finding the Height Using the Given Volume

To find the volume, V , of a prism, we multiply the area of one of the congruent bases by the perpendicular distance, d , between the two bases. Since the bases are trapezoids, we can calculate the area of the base using the formula $A = \frac{h(a+b)}{2}$, where h is the perpendicular distance between the two parallel sides a and b . We know $V = 9984 \text{ cm}^3$, $d = 40 \text{ cm}$, $a = 16 \text{ cm}$, and $b = 36 \text{ cm}$. We can find h .

$$\begin{aligned} V &= \frac{h(a+b)}{2} \times d \\ 9984 &= \frac{h(16+36)}{2} \times 40 \\ 9984 &= 26h \times 40 \\ 9984 &= 1040h \\ h &= 9.6 \text{ cm} \end{aligned}$$

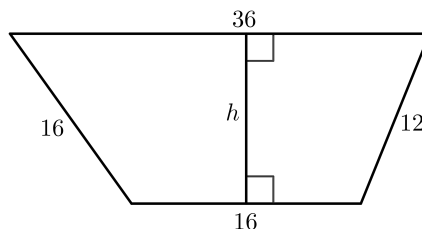

Method 2: Finding the Height Without Using the Given Volume

We start by breaking the trapezoids into two right-angled triangles and a rectangle. This can be done by drawing a line from each of the two vertices on the shorter parallel side to meet the longer parallel side at a right angle. The longer parallel side of the trapezoid breaks into pieces with lengths $a \text{ cm}$, 16 cm , and $36 - 16 - a = 20 - a \text{ cm}$. This is shown in the diagram.

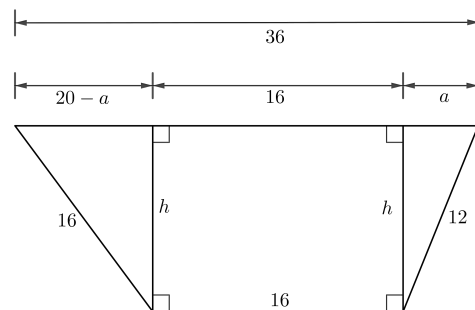

Using the Pythagorean Theorem, we can find two different expressions for h :

$$h = \sqrt{16^2 - (20-a)^2} \text{ and } h = \sqrt{12^2 - a^2}.$$

$$\text{Since } h = h, \sqrt{16^2 - (20-a)^2} = \sqrt{12^2 - a^2}.$$



Squaring both sides and expanding, we get $256 - 400 + 40a - a^2 = 144 - a^2$. Simplifying further, we get $40a = 288$, and so $a = 7.2$ cm.

Substituting $a = 7.2$ into $h = \sqrt{144 - a^2}$, we find that $h = \sqrt{144 - 7.2^2} = 9.6$ cm.

With both methods, we find that $h = 9.6$ cm. We now want to find the length of AB . Let DE represent the length of the longer parallel side of the back trapezoid, with C on DE such that $DC \perp BC$. It follows that $BC = h = 9.6$ cm.

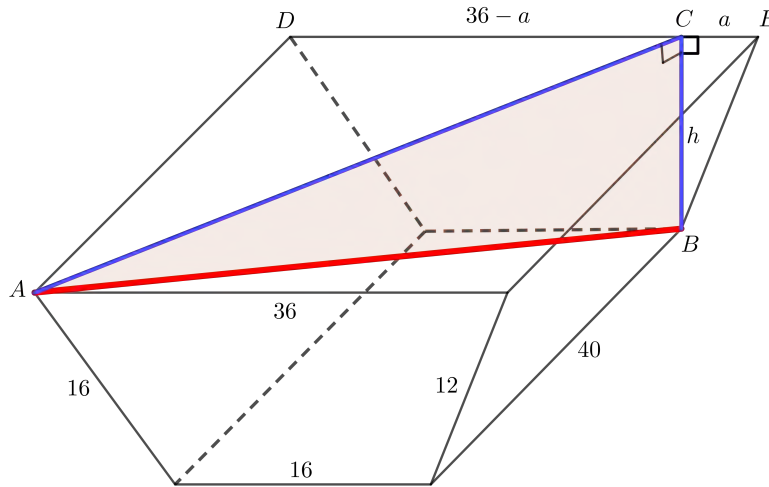

From Method 2, we know that $CE = a = 7.2$ cm. Then $DC = DE - CE = 36 - 7.2 = 28.8$ cm. The sides of the prism are perpendicular to the ends, so $AD \perp DC$ and $\triangle CDA$ is a right-angled triangle. Using the Pythagorean Theorem in $\triangle CDA$,

$$\begin{aligned} AC^2 &= DC^2 + AD^2 \\ &= 28.8^2 + 40^2 \\ &= 2429.44 \end{aligned}$$

To find the required length, AB , we note that AC is a line segment drawn across the top of the prism. BC is a line segment perpendicular to the top and bottom of the prism. It follows that $\angle ACB = 90^\circ$ and $\triangle ACB$ is a right-angled triangle. We will use the Pythagorean Theorem in $\triangle ACB$ to find the length AB .

$$\begin{aligned} AB^2 &= AC^2 + BC^2 \\ &= 2429.44 + 9.6^2 \\ &= 2521.6 \end{aligned}$$

Since $AB > 0$, then we have $AB = \sqrt{2521.6} \approx 50.2$ cm.

Therefore, length of the body diagonal, AB , is approximately 50.2 cm.



Problem of the Week

Problem E

One More Coin

A coin collecting club has between 12 and 30 members attend its monthly meeting. For one such meeting, they noticed that all of the members present each had the same number of coins except one member who had one more coin than each of the other members. Between them, the members had a total number of 1000 coins.

How many members attended the meeting?





Problem of the Week

Problem E and Solution

One More Coin

Problem

A coin collecting club has between 12 and 30 members attend its monthly meeting. For one such meeting, they noticed that all of the members present each had the same number of coins except one member who had one more coin than each of the other members. Between them, the members had a total number of 1000 coins.

How many members attended the meeting?

Solution

Let n represent the number of members present at the meeting. We know that $12 < n < 30$ and n is an integer. Let c represent the number of coins that all but one member had. That member had $c + 1$ coins. It follows that $(n - 1)$ members had c coins each and one member had $c + 1$ coins, producing a total of 1000 coins.

Thus,

$$\begin{aligned}(n - 1) \times c + 1 \times (c + 1) &= 1000 \\ nc - c + c + 1 &= 1000 \\ nc &= 999\end{aligned}$$

We are looking for two positive integers with a product of 999, with one of the numbers between 12 and 30. The prime factorization of 999 is $3 \times 3 \times 3 \times 37$. We can combine the factors to produce pairs of positive integers whose product is 999. The possibilities are 1 and 999, 3 and 333, 9 and 111, and 27 and 37. The only possible product which gives one factor between 12 and 30 is 27×37 .

It follows that there were 27 members present at the last meeting, and 26 of the members had 37 coins each and 1 member had 38 coins. This can be easily verified, as $26 \times 37 + 1 \times 38 = 1000$.



Problem of the Week
Problem E
Missing the Fives III

Bobbi lists the positive integers, in order, excluding all multiples of 5. Her resulting list is

1, 2, 3, 4, 6, 7, 8, 9, 11, 12, 13, 14, 16, 17, ...

Determine the sum of the first 2023 integers in Bobbi's list.

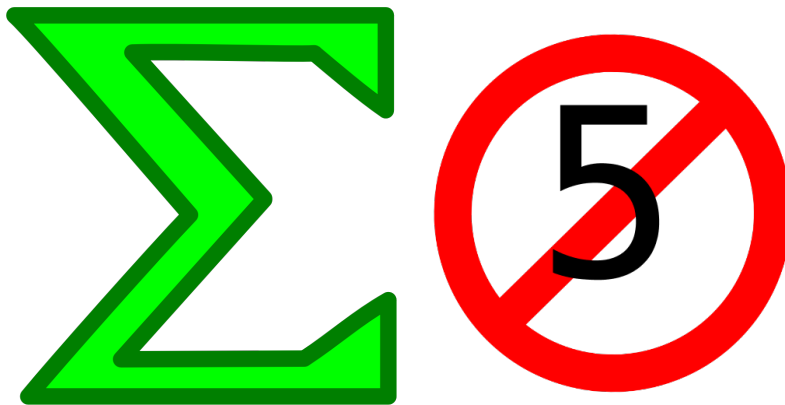

NOTE:

In solving this problem, it may be helpful to use the fact that the sum of the first n positive integers is equal to $\frac{n(n+1)}{2}$. That is,

$$1 + 2 + 3 + \cdots + n = \frac{n(n+1)}{2}$$





Problem of the Week

Problem E and Solution

Missing the Fives III

Problem

Bobbi lists the positive integers, in order, excluding all multiples of 5. Her resulting list is

$$1, 2, 3, 4, 6, 7, 8, 9, 11, 12, 13, 14, 16, 17, \dots$$

Determine the sum of the first 2023 integers in Bobbi's list.

Solution

Solution 1

We begin by determining which integers are in Bobbi's list. In each group of 5 consecutive integers beginning at 1, Bobbi lists 4 of the integers, since she leaves out each integer that is a multiple of 5. That is, in each of these groups of 5 integers, Bobbi's list contains $\frac{4}{5}$ of the integers.

Consider the positive integers from 1 to n , where n is a multiple of 5. Of these n integers, Bobbi's list contains $\frac{4}{5}n$ integers. Since Bobbi's list contains 2023 integers, which is not a multiple of 4, and 2024 is a multiple of 4, we will determine the sum of the first 2024 integers in Bobbi's list and then subtract the 2024th integer.

Now, $\frac{4}{5}n = 2024$ or $n = \frac{2024 \times 5}{4} = 2530$. So we need to determine the sum of the first 2530 positive integers with the integers that are multiples of 5 removed.

That is, we need to determine the sum

$$1 + 2 + 3 + 4 + 6 + \dots + 2524 + 2526 + 2527 + 2528 + 2529$$

We will proceed to determine this sum by first calculating the sum of the integers from 1 to 2530. We will then subtract from that sum the sum of the integers in this list that are multiples of 5. We will also need to remove 2529, which is the 2024th number in the list.

The sum of the integers from 1 to n is given by $\frac{n(n+1)}{2}$, and so the sum of the integers from 1 to 2530 is equal to $\frac{(2530)(2531)}{2} = 3\,201\,715$.

The sum of the multiples of 5 in this list, $5 + 10 + 15 + \dots + 2520 + 2525 + 2530$, can be written as $5(1 + 2 + 3 + \dots + 504 + 505 + 506)$.

This is equal to $5 \times \frac{(506)(507)}{2} = 641\,355$.

Therefore, the sum of the first 2023 integers in Bobbi's list is $3\,201\,715 - 641\,355 - 2529 = 2\,557\,831$.



Solution 2

In this solution, we will find the sum of the first 2024 integers in Bobbi's list by pairing up the integers, and then subtract the 2024th integer in her list. From Solution 1, we know that the 2024th number in Bobbi's list is 2529. Thus, the sum of the first 2024 integers in Bobbi's list is

$$1 + 2 + 3 + 4 + 6 + \cdots + 2524 + 2526 + 2527 + 2528 + 2529$$

The sum of the first and last integers in this list is $1 + 2529 = 2530$.

The sum of the second integer and the second last integer is $2 + 2528 = 2530$.

The sum of the third integer and the third last integer is $3 + 2527 = 2530$.

We continue in this way moving toward the middle of the list. That is, we move one number to the right of the previous first number, and one number to the left of the previous second number. Doing so, we notice that

- when the first number in the new pair is one more than the previous first number, then the number it is paired with is one less than the previous second number, and
- when the first number in the new pair is two more than the previous first number (as is the case when a multiple of 5 is omitted), then the number it is paired with is two less than the previous second number.

That is, as we continue moving toward the middle of Bobbi's list, each pair will continue to have a sum equal to 2530. Since there are 2024 numbers in Bobbi's list, there are 1012 such pairs, each having a sum of 2530. Thus, if Bobbi lists the positive integers, in order, leaving out the integers that are multiples of 5, the sum of the first 2024 integers in her list is $1012 \times 2530 = 2\,560\,360$. However, this includes the 2024th integer in her list. Therefore, the sum of the first 2023 integers in Bobbi's list is $2\,560\,360 - 2529 = 2\,557\,831$.



Problem of the Week

Problem E

Three Squares

The three squares $ABCD$, $AEFG$, and $AHJK$ overlap as shown in the diagram.

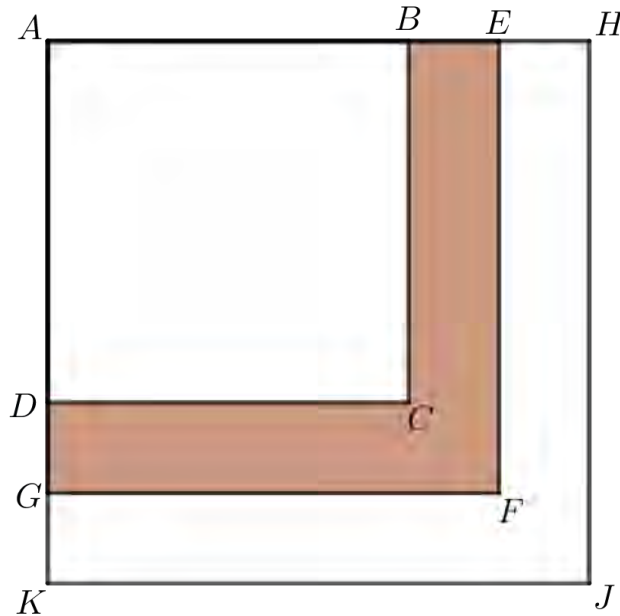

The side length of each square, in centimetres, is a positive integer. The area of square $AEFG$ that is not covered by square $ABCD$ is 33 cm^2 . That is, the area of the shaded region $BEFGDC$ is 33 cm^2 . If $DG = GK$, determine all possible side lengths of each square.



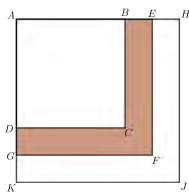

Problem of the Week

Problem E and Solution

Three Squares

Problem

The three squares $ABCD$, $AEFG$, and $AHJK$ overlap as shown in the diagram.

The side length of each square, in centimetres, is a positive integer. The area of square $AEFG$ that is not covered by square $ABCD$ is 33 cm^2 . That is, the area of the shaded region $BEFGDC$ is 33 cm^2 . If $DG = GK$, determine all possible side lengths of each square.

Solution

Let $AD = x \text{ cm}$ and $DG = y \text{ cm}$. Therefore $GK = DG = y \text{ cm}$. Also, since the side length of each square is an integer, x and y are integers.

The shaded region has area 33 cm^2 . The shaded region is equal to the area of the square with side length AG minus the area of the square with side length AD .

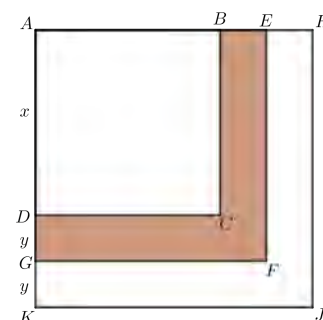

Since $AD = x$ and $AG = AD + DG = x + y$, we have

$$\begin{aligned} 33 &= (\text{area of square with side length } AG) - (\text{area of square with side length } AD) \\ &= (x + y)^2 - x^2 \\ &= x^2 + 2xy + y^2 - x^2 \\ &= 2xy + y^2 \\ &= y(2x + y) \end{aligned}$$

Since x and y are integers, so is $2x + y$. Therefore, $2x + y$ and y are two positive integers that multiply to give 33. Therefore, we must have $y = 1$ and $2x + y = 33$, or $y = 3$ and $2x + y = 11$, or $y = 11$ and $2x + y = 3$, or $y = 33$ and $2x + y = 1$. The last two would imply that $x < 0$, which is not possible. Therefore, $y = 1$ and $2x + y = 33$, or $y = 3$ and $2x + y = 11$.

When $y = 1$ and $2x + y = 33$, it follows that $x = 16$. Then square $ABCD$ has side length $x = 16 \text{ cm}$, square $AEFG$ has side length $x + y = 17 \text{ cm}$, and square $AHJK$ has side length $x + 2y = 18 \text{ cm}$.

When $y = 3$ and $2x + y = 11$, it follows that $x = 4$. Then square $ABCD$ has side length $x = 4 \text{ cm}$, square $AEFG$ has side length $x + y = 7 \text{ cm}$, and square $AHJK$ has side length $x + 2y = 10 \text{ cm}$.

Therefore, there are two possible sets of squares. The squares are either $16 \text{ cm} \times 16 \text{ cm}$ and $17 \text{ cm} \times 17 \text{ cm}$ and $18 \text{ cm} \times 18 \text{ cm}$, or $4 \text{ cm} \times 4 \text{ cm}$ and $7 \text{ cm} \times 7 \text{ cm}$ and $10 \text{ cm} \times 10 \text{ cm}$. Each of these sets of squares satisfies the conditions of the problem.



Problem of the Week

Problem E

How Far From Here to There

A cyclist leaves the town of Alphaville and heads toward Betaville. She travels at a constant speed of 14 km/h.

At the same time, a jogger and a walker leave Betaville and head toward Alphaville. The walker travels at a constant speed of 6 km/h and the jogger travels at a constant speed of 10 km/h.

If the cyclist passes the walker 4 minutes after passing the jogger, how far apart are the towns Alphaville and Betaville?





Problem of the Week

Problem E and Solution

How Far From Here to There



Problem

A cyclist leaves the town of Alphaville and heads toward Betaville. She travels at a constant speed of 14 km/h.

At the same time, a jogger and a walker leave Betaville and head toward Alphaville. The walker travels at a constant speed of 6 km/h and the jogger travels at a constant speed of 10 km/h.

If the cyclist passes the walker 4 minutes after passing the jogger, how far apart are the towns Alphaville and Betaville?

Solution

Let d be the distance, in km, between the towns Alphaville and Betaville.

Let t be the time, in hours, until the jogger and cyclist meet.

Using the formula distance = speed \times time, in t hours the cyclist travels $14t$ km and the jogger travels $10t$ km.

Between the cyclist and jogger, they travel the total distance between Alphaville and Betaville in t hours. Therefore, $d = 14t + 10t = 24t$.

The cyclist meets the walker 4 minutes, or $\frac{4}{60} = \frac{1}{15}$ hours, after meeting the jogger. Therefore, $(t + \frac{1}{15})$ is the time, in hours, until the cyclist meets the walker.

Again, using the formula distance = speed \times time, in $(t + \frac{1}{15})$ hours, the cyclist travels $14(t + \frac{1}{15})$ km and the walker travels $6(t + \frac{1}{15})$ km.

Between the cyclist and walker, they travel the total distance between Alphaville and Betaville in $(t + \frac{1}{15})$ hours. Therefore, $d = 14(t + \frac{1}{15}) + 6(t + \frac{1}{15}) = 20(t + \frac{1}{15})$.

Thus, $d = 24t$ and $d = 20(t + \frac{1}{15})$. Therefore,

$$24t = 20\left(t + \frac{1}{15}\right)$$

$$24t = 20t + \frac{4}{3}$$

$$4t = \frac{4}{3}$$

$$t = \frac{1}{3}$$

Since $t = \frac{1}{3}$ hours, we find $d = 24t = 24\left(\frac{1}{3}\right) = 8$ km.

Therefore, the towns of Alphaville and Betaville are 8 km apart.



Problem of the Week

Problem E

Fill ALL the Squares

Twelve squares are placed in a row forming the grid below. Each square is to be filled with an integer. After the third square, each integer in a square is the sum of the previous three integers. If we know the third integer is 6, the sixth integer is 11, and the eleventh integer is 14, determine all of the integers in the grid.

		6			11					14	
--	--	---	--	--	----	--	--	--	--	----	--



Problem of the Week

Problem E and Solution

Fill ALL the Squares

Problem

Twelve squares are placed in a row forming the grid below. Each square is to be filled with an integer. After the third square, each integer in a square is the sum of the previous three integers. If we know the third integer is 6, the sixth integer is 11, and the eleventh integer is 14, determine all of the integers in the grid.

		6			11					14	
--	--	---	--	--	----	--	--	--	--	----	--

Solution

Let a_1 be the first integer in the grid, a_2 be the second, a_3 be the third, a_4 be the fourth, and so on, until a_{12} which is the twelfth integer in the grid. We are given that $a_3 = 6$, $a_6 = 11$, and $a_{11} = 14$.

Each integer after the third integer is equal to the sum of the previous three integers. Therefore, $a_6 = a_3 + a_4 + a_5$. Thus, $11 = 6 + a_4 + a_5$ or $a_4 + a_5 = 5$.

We also have $a_7 = a_4 + a_5 + a_6 = a_4 + a_5 + 11 = 5 + 11 = 16$, since $a_4 + a_5 = 5$.

Similarly,

$$a_9 = a_6 + a_7 + a_8 = 11 + 16 + a_8 = 27 + a_8,$$

$$a_{10} = a_7 + a_8 + a_9 = 16 + a_8 + a_9 = 16 + (a_8) + (a_8 + 27) = 2a_8 + 43, \text{ and}$$

$$a_{11} = a_8 + a_9 + a_{10} = (a_8) + (a_8 + 27) + (2a_8 + 43) = 4a_8 + 70.$$

We are given that $a_{11} = 14$. Therefore, $4a_8 + 70 = 14$, or $4a_8 = -56$, or $a_8 = -14$.

Therefore, $a_9 = a_8 + 27 = -14 + 27 = 13$, and $a_{10} = 2a_8 + 43 = 2(-14) + 43 = 15$.

Also, $a_{12} = a_9 + a_{10} + a_{11} = 13 + 15 + 14 = 42$.

So far, we know that the integers in the grid, from left to right are

$$a_1, a_2, 6, a_4, a_5, 11, 16, -14, 13, 15, 14, 42$$

Working backwards, $-14 = a_5 + 11 + 16$, so $a_5 = -41$.

From earlier, $a_4 + a_5 = 5$. Since $a_5 = -41$, we know $a_4 = 46$.

Continuing working backwards, $a_5 = a_2 + 6 + a_4$, so $-41 = a_2 + 6 + 46$, or $a_2 = -93$.

Finally, $a_4 = a_1 + a_2 + 6$, so $46 = a_1 + (-93) + 6$, or $a_1 = 133$.

Therefore, the twelve integers in the grid, from left to right, are

$$133, -93, 6, 46, -41, 11, 16, -14, 13, 15, 14, 42$$

The filled grid is shown below. We can indeed check that each integer after the first three integers is equal to the sum of the previous three integers.

133	-93	6	46	-41	11	16	-14	13	15	14	42
-----	-----	---	----	-----	----	----	-----	----	----	----	----



Problem of the Week

Problem E

A Lot of Zeros

For a positive integer n , the product of the integers from 1 to n can be written in abbreviated form as $n!$, which we read as “ n factorial”. So,

$$n! = n \times (n - 1) \times (n - 2) \times \cdots \times 3 \times 2 \times 1$$

For example,

$$6! = 6 \times 5 \times 4 \times 3 \times 2 \times 1 = 720, \text{ and}$$

$$11! = 11 \times 10 \times 9 \times \cdots \times 3 \times 2 \times 1 = 39\,916\,800.$$

Note that $6!$ ends in one zero and $11!$ ends in two zeros.

Determine the smallest positive integer n such that $n!$ ends in exactly 1000 zeros.

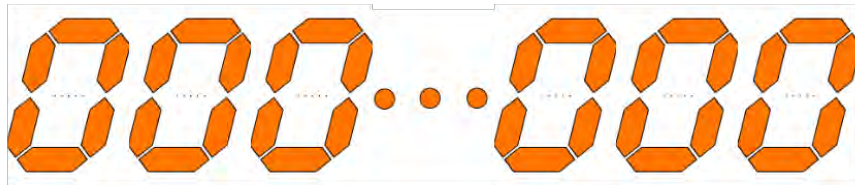



Problem of the Week

Problem E and Solution

A Lot of Zeros

Problem

For a positive integer n , the product of the integers from 1 to n can be written in abbreviated form as $n!$, which we read as “ n factorial”. So,

$$n! = n \times (n - 1) \times (n - 2) \times \cdots \times 3 \times 2 \times 1$$

For example,

$$6! = 6 \times 5 \times 4 \times 3 \times 2 \times 1 = 720, \text{ and } 11! = 11 \times 10 \times 9 \times \cdots \times 3 \times 2 \times 1 = 39\,916\,800.$$

Note that $6!$ ends in one zero and $11!$ ends in two zeros.

Determine the smallest positive integer n such that $n!$ ends in exactly 1000 zeros.

Solution

When finding a solution to this problem, it may be helpful to work with possible values for n to determine the number of zeros that $n!$ ends in. One could use a calculator as part of this, but many standard calculators switch to scientific notation around $14!$. A trial and error approach could work but it may be very time consuming. Our approach will be more systematic.

A zero is added to the end of a positive integer when we multiply by 10. Multiplying a number by 10 is the same as multiplying a number by 2 and then by 5, or by 5 and then by 2, since $2 \times 5 = 10$ and $5 \times 2 = 10$.

So we want n to be the smallest positive integer such that the prime factorization of $n!$ contains 1000 5s and 1000 2s. Every even positive integer has a 2 in its prime factorization and every positive integer that is a multiple of 5 has a 5 in its prime factorization. There are more positive integers less than or equal to n that are multiples of 2 than multiples of 5. So once we find a positive integer n such that $n!$ has 1000 5s in its prime factorization, we can stop, we know that there will be a sufficient number of 2s in its prime factorization.

There are $\lfloor \frac{n}{5} \rfloor$ positive integers less than or equal to n that are divisible by 5. Note, the notation $\lfloor x \rfloor$ means *the floor of x* and is the largest integer less than or equal to x . So $\lfloor 4.2 \rfloor = 4$, $\lfloor 4.9 \rfloor = 4$ and $\lfloor 4 \rfloor = 4$. Also, since $5 \times 1000 = 5000$, we know that $n \leq 5000$.

Numbers that are divisible by 25 will add an additional factor of 5, since $25 = 5 \times 5$.

There are $\lfloor \frac{n}{25} \rfloor$ positive integers less than or equal to n that are divisible by 25.

Numbers that are divisible by 125 will add an additional factor of 5, since $125 = 5 \times 5 \times 5$ and two of the factors have already been counted when we looked at 5 and 25.

There are $\lfloor \frac{n}{125} \rfloor$ positive integers less than or equal to n that are divisible by 125.

Numbers that are divisible by 625 will add an additional factor of 5, since $625 = 5 \times 5 \times 5 \times 5$ and three of the factors have already been counted when we looked at 5, 25, and 125.

There are $\lfloor \frac{n}{625} \rfloor$ positive integers less than or equal to n that are divisible by 625.

Numbers that are divisible by 3125 will add an additional factor of 5, since $3125 = 5^5$ and four of the factors have already been counted when we looked at 5, 25, 125, and 625.



There are $\lfloor \frac{n}{3125} \rfloor$ positive integers less than or equal to n that are divisible by 3125.

The next power of 5 to consider is $5^6 = 15\,625$. But since $n \leq 5000$, we do not need to consider this power of 5 or any larger power.

Thus, we know that n must satisfy the equation

$$\left\lfloor \frac{n}{5} \right\rfloor + \left\lfloor \frac{n}{25} \right\rfloor + \left\lfloor \frac{n}{125} \right\rfloor + \left\lfloor \frac{n}{625} \right\rfloor + \left\lfloor \frac{n}{3125} \right\rfloor = 1000$$

Let's ignore the floor function. We know that n is going to be *close* to satisfying

$$\begin{aligned} \frac{n}{5} + \frac{n}{25} + \frac{n}{125} + \frac{n}{625} + \frac{n}{3125} &= 1000 \\ \frac{625n}{3125} + \frac{125n}{3125} + \frac{25n}{3125} + \frac{5n}{3125} + \frac{n}{3125} &= 1000 \\ \frac{781}{3125}n &= 1000 \\ n &= \frac{1000 \times 3125}{781} \\ n &\approx 4001.2 \end{aligned}$$

The number of zeros at the end of 4001! is equal to

$$\begin{aligned} &\left\lfloor \frac{4001}{5} \right\rfloor + \left\lfloor \frac{4001}{25} \right\rfloor + \left\lfloor \frac{4001}{125} \right\rfloor + \left\lfloor \frac{4001}{625} \right\rfloor + \left\lfloor \frac{4001}{3125} \right\rfloor \\ &= \lfloor 800.2 \rfloor + \lfloor 160.04 \rfloor + \lfloor 32.008 \rfloor + \lfloor 6.4016 \rfloor + \lfloor 1.28032 \rfloor \\ &= 800 + 160 + 32 + 6 + 1 \\ &= 999 \end{aligned}$$

Therefore, the number 4001! ends in 999 zeros. We need one more factor of 5 in order to have 1000 zeros at the end. The first integer after 4001 that is divisible by 5 is 4005.

Therefore, 4005 is the smallest positive integer such that 4005! ends in 1000 zeros.

Indeed, we can check. The number of zeros at the end of 4004! is equal to the number of 5s in its prime factorization, which is equal to

$$\begin{aligned} &\left\lfloor \frac{4004}{5} \right\rfloor + \left\lfloor \frac{4004}{25} \right\rfloor + \left\lfloor \frac{4004}{125} \right\rfloor + \left\lfloor \frac{4004}{625} \right\rfloor + \left\lfloor \frac{4004}{3125} \right\rfloor \\ &= \lfloor 800.8 \rfloor + \lfloor 160.16 \rfloor + \lfloor 32.032 \rfloor + \lfloor 6.4064 \rfloor + \lfloor 1.28128 \rfloor \\ &= 800 + 160 + 32 + 6 + 1 \\ &= 999 \end{aligned}$$

The number of zeros at the end of 4005! is equal to the number of 5s in its prime factorization, which is equal to

$$\begin{aligned} &\left\lfloor \frac{4005}{5} \right\rfloor + \left\lfloor \frac{4005}{25} \right\rfloor + \left\lfloor \frac{4005}{125} \right\rfloor + \left\lfloor \frac{4005}{625} \right\rfloor + \left\lfloor \frac{4005}{3125} \right\rfloor \\ &= \lfloor 801 \rfloor + \lfloor 160.2 \rfloor + \lfloor 32.04 \rfloor + \lfloor 6.408 \rfloor + \lfloor 1.2816 \rfloor \\ &= 801 + 160 + 32 + 6 + 1 \\ &= 1000 \end{aligned}$$



Problem of the Week

Problem E

A Pinch of Salt?

A container initially contained 320 grams of common salt.

Mixture Y was formed by taking x grams of the common salt out of the container, adding x grams of Himalayan Pink Salt to the container, and then mixing uniformly. In Mixture Y, the ratio of the mass of the common salt to the mass of the Himalayan Pink Salt, expressed in lowest terms, was $c : h$.

Mixture Z was then formed by taking x grams of Mixture Y out of the container, adding x grams of Himalayan Pink Salt to the container, and then mixing uniformly. In Mixture Z, the ratio of the mass of the common salt to the mass of the Himalayan Pink Salt was $49 : 15$.

What is the value of $x + c + h$?





Problem of the Week

Problem E and Solution

A Pinch of Salt?

Problem

A container initially contained 320 grams of common salt.

Mixture Y was formed by taking x grams of the common salt out of the container, adding x grams of Himalayan Pink Salt to the container, and then mixing uniformly. In Mixture Y, the ratio of the mass of the common salt to the mass of the Himalayan Pink Salt, expressed in lowest terms, was $c : h$.

Mixture Z was then formed by taking x grams of Mixture Y out of the container, adding x grams of Himalayan Pink Salt to the container, and then mixing uniformly. In Mixture Z, the ratio of the mass of the common salt to the mass of the Himalayan Pink Salt was $49 : 15$.

What is the value of $x + c + h$?

Solution

Initially, the container contained 320 g of common salt and 0 g of Himalayan Pink Salt.

Mixture Y contained $(320 - x)$ g of common salt and x g of Himalayan Pink Salt. When Mixture Z (the final mixture) is formed, there was still a total of 320 g of salt in the bowl.

In Mixture Z, the ratio of the mass of common salt to the mass of Himalayan Pink Salt is $49 : 15$. Therefore, the mass of common salt is $\frac{49}{49+15} \cdot 320 = \frac{49}{64} \cdot 320 = 49 \cdot 5 = 245$ g and the mass of Himalayan Pink Salt in Mixture Z is $320 - 245 = 75$ g.

Mixture Y consisted of $(320 - x)$ g of common salt and x g of Himalayan Pink Salt, which were thoroughly mixed together. Therefore, each gram of Mixture Y consisted of $\frac{320-x}{320}$ g of common salt and $\frac{x}{320}$ g of Himalayan Pink Salt.

To form Mixture Z, x g of Mixture Y was removed. This amount of Mixture Y that was removed contained $x \cdot \frac{x}{320} = \frac{x^2}{320}$ g of Himalayan Pink Salt. Therefore, the mass of Himalayan Pink Salt in Mixture Z is the original x g added to get Mixture Y minus the $\frac{x^2}{320}$ g from mixture Y plus the new x g making $x - \frac{x^2}{320} + x = 2x - \frac{x^2}{320}$ g of Himalayan Pink Salt.

But we determined earlier that Mixture Z contains 75 g of Himalayan Pink Salt. Therefore,

$$\begin{aligned}2x - \frac{x^2}{320} &= 75 \\0 &= x^2 - 2(320)x + 75(320) \\0 &= x^2 - 640x + 24\,000 \\0 &= (x - 40)(x - 600)\end{aligned}$$

Therefore, $x = 40$ or $x = 600$.

Since the initial mixture consisted of 320 g of common salt, then we must have $x < 320$. It follows that $x = 40$.

Therefore, Mixture Y consisted of $320 - 40 = 280$ g of common salt and 40 g of Himalayan Pink Salt. The ratio of these masses is $280 : 40$ or $7 : 1$ in lowest terms. Thus, $c = 7$ and $h = 1$.

Therefore, $x + c + h = 40 + 7 + 1 = 48$.



Problem of the Week

Problem E

Sum Product Function

A function, g , has $g(2) = 5$ and $g(3) = 7$. In addition, g has the property that

$$g(a) + g(b) = g(ab)$$

for all positive integers a and b .

For example, $g(6) = g(2) + g(3) = 12$.

What is the value of $g(648)$?

$$g(a) + g(b) = g(ab)$$





Problem of the Week

$$g(a) + g(b) = g(ab) \quad \text{Problem E and Solution}$$

Sum Product Function

Problem

A function, g , has $g(2) = 5$ and $g(3) = 7$. In addition, g has the property that

$$g(a) + g(b) = g(ab)$$

for all positive integers a and b .

For example, $g(6) = g(2) + g(3) = 12$.

What is the value of $g(648)$?

Solution

We can rewrite $g(648)$ as:

$$\begin{aligned} g(648) &= g(2 \cdot 324) \\ &= g(2) + g(324) \\ &= g(2) + g(2 \cdot 162) \\ &= g(2) + g(2) + g(162) \\ &= g(2) + g(2) + g(2 \cdot 81) \\ &= g(2) + g(2) + g(2) + g(81) \\ &= g(2) + g(2) + g(2) + g(3 \cdot 27) \\ &= g(2) + g(2) + g(2) + g(3) + g(27) \\ &= g(2) + g(2) + g(2) + g(3) + g(3 \cdot 9) \\ &= g(2) + g(2) + g(2) + g(3) + g(3) + g(9) \\ &= g(2) + g(2) + g(2) + g(3) + g(3) + g(3 \cdot 3) \\ &= g(2) + g(2) + g(2) + g(3) + g(3) + g(3) + g(3) \end{aligned}$$

Therefore, $g(648) = 3g(2) + 4g(3) = 3(5) + 4(7) = 43$.

NOTE:

While this answers the question, is there actually a function that satisfies the requirements?

The answer is yes.

One function that satisfies the requirements of the problem is the function g defined by

$$g(1) = 0 \text{ and } g(2^p 3^q r) = 5p + 7q$$

for all non-negative integers p and q and all positive integers r that are not divisible by 2 or by 3. Can you see why this function satisfies the requirements?

Geometry & Measurement (G)





Problem of the Week

Problem E

A Rectangle and a Square

Simeon has a rope that is 108 cm long and is asked to cut the rope once so that one of the pieces can be arranged, with its two ends touching, to form a square, and the other piece can be arranged, with its two ends touching, to form a rectangle with one side length of 6 cm. Furthermore, the area of the square will be equal to the area of the rectangle.

Where should Simeon make the cut to the original piece of rope?

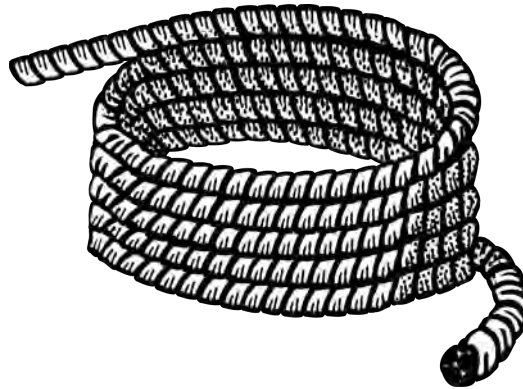

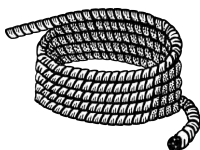

Problem of the Week

Problem E and Solution

A Rectangle and a Square

Problem

Simeon has a rope that is 108 cm long and is asked to cut the rope once so that one of the pieces can be arranged, with its two ends touching, to form a square, and the other piece can be arranged, with its two ends touching, to form a rectangle with one side length of 6 cm. Furthermore, the area of the square will be equal to the area of the rectangle.

Where should Simeon make the cut to the original piece of rope?

Solution

Let the length of the piece of rope used to form the square be $4x$ cm. This is also equal to the perimeter of the square. Then the side length of the square is $4x \div 4 = x$ cm. The area of the square is

$$x \times x = x^2 \text{ cm}^2 \quad (1)$$

The length of the piece of rope used to form the rectangle is $(108 - 4x)$ cm. This is also equal to the perimeter of the rectangle. If one side length of the rectangle is 6 cm, then there is $108 - 4x - 6 - 6 = (96 - 4x)$ cm left to form the lengths of the two other sides of the rectangle. Therefore, the other side length of the rectangle is $\frac{96-4x}{2} = (48 - 2x)$ cm. Thus, the area of the rectangle is

$$(6)(48 - 2x) = (288 - 12x) \text{ cm}^2 \quad (2)$$

We are given that the area of the square is equal to the area of the rectangle. So, by equating equations (1) and (2), we obtain

$$\begin{aligned} x^2 &= 288 - 12x \\ x^2 + 12x - 288 &= 0 \\ (x - 12)(x + 24) &= 0 \end{aligned}$$

Thus, $x = 12$ or $x = -24$. Since x is the length of the side of the square, we must have $x > 0$. Therefore, $x = 12$ cm. Then the length of rope used to form the square is $4x = 4(12) = 48$ cm.

Therefore, the cut should be made 48 cm from one end (and so 60 cm from the other end), creating a 60 cm piece for the rectangle and a 48 cm piece for the square.

NOTE:

The area of the square is $12 \times 12 = 144 \text{ cm}^2$.

The length of the other side of the rectangle is $48 - 2x = 48 - 24 = 24$ cm. The area of the rectangle is $24 \times 6 = 144 \text{ cm}^2$.

(These calculations were not required but are provided as a check of the correctness of the result.)



Problem of the Week

Problem E

The Other Side

In $\triangle STU$, a median is drawn from vertex S , meeting side TU at point M . The length of side ST is 7 cm, the length of side SU is 9 cm, and the length of the median SM is 7 cm.

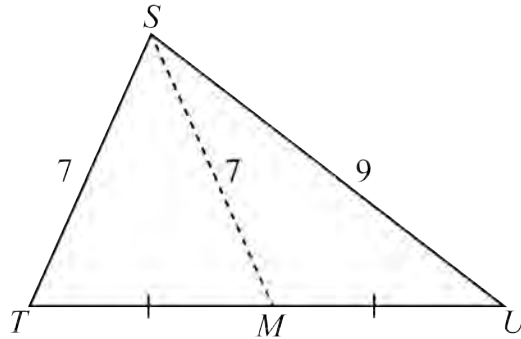

Determine the length of TU .



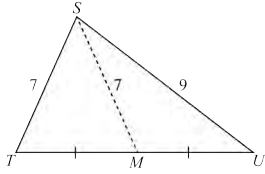

Problem of the Week

Problem E and Solution

The Other Side

Problem

In $\triangle STU$, a median is drawn from vertex S , meeting side TU at point M . The length of side ST is 7 cm, the length of side SU is 9 cm, and the length of the median SM is 7 cm. Determine the length of TU .

Solution

Solution 1

Since $ST = SM = 7$, $\triangle STM$ is isosceles. In $\triangle STM$, draw an altitude from vertex S to TM , intersecting TM at N . Let $TN = x$. In an isosceles triangle, the altitude drawn to the base bisects the base. Therefore, $NM = TN = x$. Since SM is a median in $\triangle STU$, it follows that $MU = TM = 2x$. Let $SN = h$.

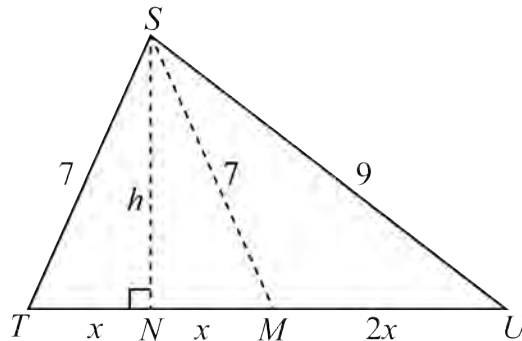

Since $\triangle SNM$ is a right-angled triangle, we can use the Pythagorean Theorem as follows.

$$\begin{aligned}SN^2 &= SM^2 - NM^2 \\h^2 &= 7^2 - x^2 \\h^2 &= 49 - x^2\end{aligned}\tag{1}$$

Since $\triangle SNU$ is a right-angled triangle, we can use the Pythagorean Theorem as follows.

$$\begin{aligned}SN^2 &= SU^2 - NU^2 \\h^2 &= 9^2 - (x + 2x)^2 \\h^2 &= 81 - (3x)^2 \\h^2 &= 81 - 9x^2\end{aligned}\tag{2}$$



In both equations (1) and (2), the left side is h^2 . Therefore, the right side of equation (1) must equal the right side of equation (2).

$$\begin{aligned}49 - x^2 &= 81 - 9x^2 \\-x^2 + 9x^2 &= 81 - 49 \\8x^2 &= 32 \\x^2 &= 4\end{aligned}$$

Since $x > 0$, it follows that $x = 2$.

Therefore, $TU = TN + NM + MU = x + x + 2x = 4x = 4(2) = 8$ cm.

Solution 2

This solution is presented for students who have done some trigonometry and know the Cosine Law. Since SM is a median, let $TM = MU = y$. Then $TU = 2y$.

Using the Cosine Law in $\triangle STM$,

$$\begin{aligned}SM^2 &= ST^2 + TM^2 - 2(ST)(TM) \cos T \\7^2 &= 7^2 + y^2 - 2(7)(y) \cos T \\49 &= 49 + y^2 - 14y \cos T \\14y \cos T &= y^2\end{aligned}\tag{1}$$

Using the Cosine Law in $\triangle STU$,

$$\begin{aligned}SU^2 &= ST^2 + TU^2 - 2(ST)(TU) \cos T \\9^2 &= 7^2 + (2y)^2 - 2(7)(2y) \cos T \\81 &= 49 + 4y^2 - 28y \cos T \\28y \cos T &= 4y^2 - 32 \\14y \cos T &= 2y^2 - 16\end{aligned}\tag{2}$$

Subtracting equation (2) from equation (1) allows us to solve for y .

$$\begin{aligned}14y \cos T &= y^2 && (1) \\14y \cos T &= 2y^2 - 16 && (2) \\0 &= -y^2 + 16 \\y^2 &= 16\end{aligned}$$

Since $y > 0$, it follows that $y = 4$.

Therefore, the length of TU is $2(4) = 8$ cm.



Problem of the Week

Problem E

The Angle Between

Rectangle $PQRS$ has $PQ = 3$ and $QR = 4$. Points T and U are on side PS such that $PT = US = 1$.

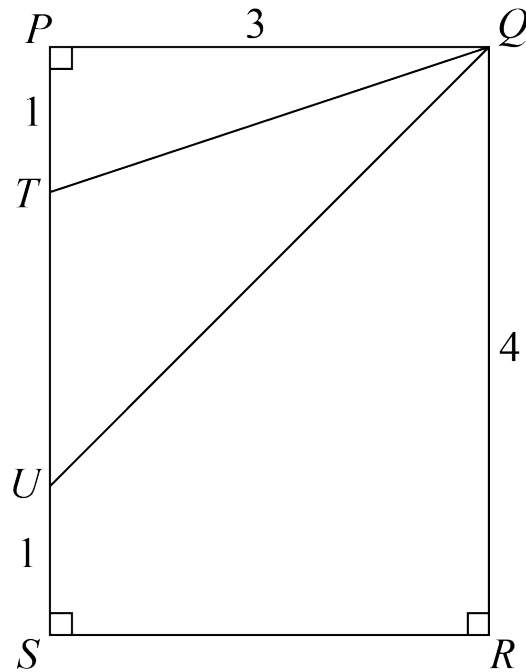

Determine the measure of $\angle TQU$, in degrees and rounded to 1 decimal place.





Problem of the Week

Problem E and Solution

The Angle Between

Problem

Rectangle $PQRS$ has $PQ = 3$ and $QR = 4$. Points T and U are on side PS such that $PT = US = 1$. Determine the measure of $\angle TQU$, in degrees and rounded to 1 decimal place.

Solution

Let X be the point on QR such that UX is parallel to SR . Then $\angle UXQ = 90^\circ$. Also, $UX = SR = 3$, $XR = US = 1$, and therefore $QX = 3$.

It follows that $\triangle UXQ$ is an isosceles right-angled triangle, and so $\angle UQX = \angle QUX = 45^\circ$.

From here we present three different solutions.

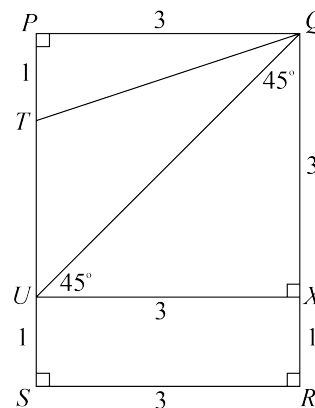

Solution 1

Since $\triangle TPQ$ is a right-angled triangle, $\tan(\angle TQP) = \frac{1}{3}$, and so $\angle TQP \approx 18.4^\circ$.

Since $\angle PQX = 90^\circ$, we can calculate the value of $\angle TQU$ as follows.

$$\begin{aligned}\angle PQX &= \angle PQT + \angle TQU + \angle UQX \\ \angle TQU &= \angle PQX - \angle PQT - \angle UQX \\ \angle TQU &\approx 90^\circ - 18.4^\circ - 45^\circ \\ \angle TQU &\approx 26.6^\circ\end{aligned}$$

Therefore, $\angle TQU \approx 26.6^\circ$.

Solution 2

Since $\triangle TPQ$ is a right-angled triangle, by the Pythagorean Theorem, $TQ^2 = PT^2 + PQ^2 = 1^2 + 3^2 = 10$. Therefore $TQ = \sqrt{10}$, since $TQ > 0$.

Since $PQRS$ is a rectangle, $PS = QR = 4$, and $PT = US = 1$, it follows that $TU = 2$. Since $\triangle UXQ$ is a right-angled triangle, by the Pythagorean Theorem, $QU^2 = UX^2 + QX^2 = 3^2 + 3^2 = 18$. Therefore $QU = \sqrt{18}$, since $QU > 0$. Now we will use the cosine law in $\triangle TQU$.



$$TU^2 = TQ^2 + QU^2 - 2(TQ)(QU) \cos(\angle TQU)$$

$$2^2 = 10 + 18 - 2(\sqrt{10})(\sqrt{18}) \cos(\angle TQU)$$

$$4 - 10 - 18 = -2\sqrt{10}\sqrt{18} \cos(\angle TQU)$$

$$-24 = -2\sqrt{10}\sqrt{18} \cos(\angle TQU)$$

$$\frac{12}{\sqrt{10}\sqrt{18}} = \cos(\angle TQU)$$

$$\angle TQU \approx 26.6^\circ$$

Therefore, $\angle TQU \approx 26.6^\circ$.

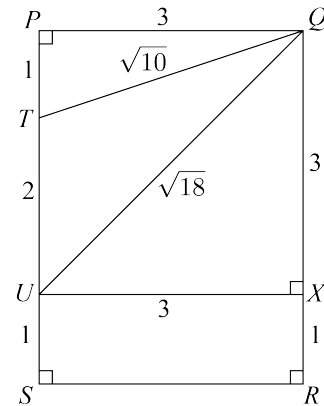

Solution 3

Since $\triangle TPQ$ is a right-angled triangle, by the Pythagorean Theorem, $TQ^2 = PT^2 + PQ^2 = 1^2 + 3^2 = 10$. Therefore $TQ = \sqrt{10}$, since $TQ > 0$.

Since $PQRS$ is a rectangle, $PS = QR = 4$, and $PT = US = 1$, it follows that $TU = 2$.

Since UX is parallel to SR , then $\angle PUX = 90^\circ$. Since $\angle QUX = 45^\circ$, it follows that $\angle TUQ = 45^\circ$.

Now we will use the sine law in $\triangle TQU$.

$$\frac{\sin(\angle TQU)}{TU} = \frac{\sin(\angle TUQ)}{TQ}$$

$$\frac{\sin(\angle TQU)}{2} = \frac{\sin 45^\circ}{\sqrt{10}}$$

$$\angle TQU \approx 26.6^\circ$$

Therefore, $\angle TQU \approx 26.6^\circ$.

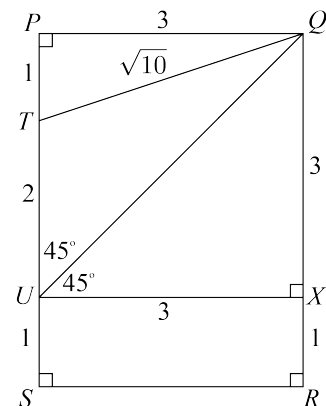



Problem of the Week

Problem E

Across the Prism

A trapezoidal prism is a prism in which opposite parallel ends are congruent trapezoids.

For the trapezoidal prism shown, the opposite parallel sides of each trapezoid are 36 cm and 16 cm in length. The non-parallel sides of each trapezoid are 16 cm and 12 cm in length. The prism is 40 cm long. The volume of the prism is 9984 cm^3 .

A body diagonal of a prism is a line connecting two vertices that are not on the same face. Find the length of the body diagonal AB (indicated in the diagram), accurate to 1 decimal place.

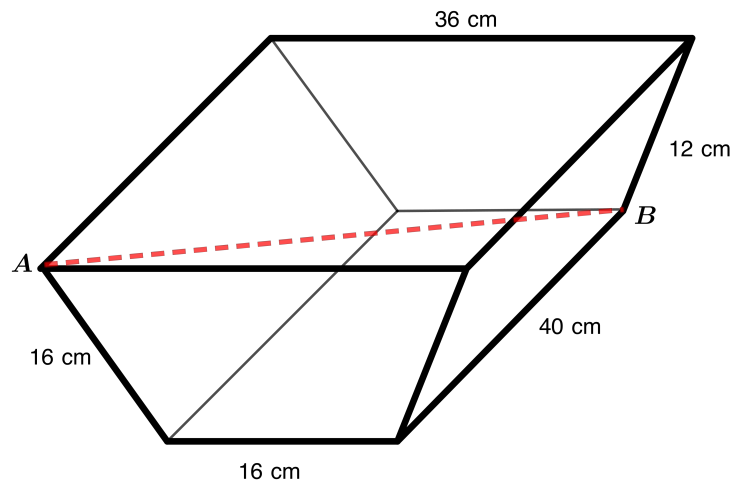

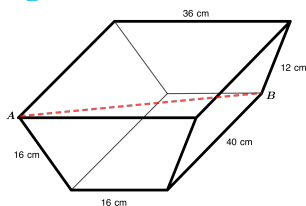

Problem of the Week

Problem E and Solution

Across the Prism

Problem

A trapezoidal prism is a prism in which opposite parallel ends are congruent trapezoids.

For the trapezoidal prism shown, the opposite parallel sides of each trapezoid are 36 cm and 16 cm in length. The non-parallel sides of each trapezoid are 16 cm and 12 cm in length. The prism is 40 cm long. The volume of the prism is 9984 cm^3 .

A body diagonal of a prism is a line connecting two vertices that are not on the same face. Find the length of the body diagonal AB (indicated in the diagram), accurate to 1 decimal place.

Solution

Let h represent the height of the trapezoid. We will determine the height using two different methods.

Method 1: Finding the Height Using the Given Volume

To find the volume, V , of a prism, we multiply the area of one of the congruent bases by the perpendicular distance, d , between the two bases. Since the bases are trapezoids, we can calculate the area of the base using the formula $A = \frac{h(a+b)}{2}$, where h is the perpendicular distance between the two parallel sides a and b . We know $V = 9984 \text{ cm}^3$, $d = 40 \text{ cm}$, $a = 16 \text{ cm}$, and $b = 36 \text{ cm}$. We can find h .

$$\begin{aligned} V &= \frac{h(a+b)}{2} \times d \\ 9984 &= \frac{h(16+36)}{2} \times 40 \\ 9984 &= 26h \times 40 \\ 9984 &= 1040h \\ h &= 9.6 \text{ cm} \end{aligned}$$

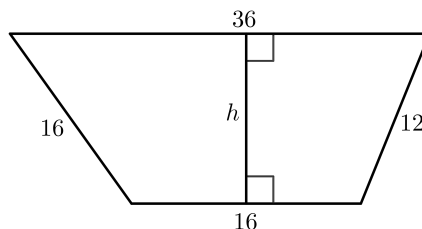

Method 2: Finding the Height Without Using the Given Volume

We start by breaking the trapezoids into two right-angled triangles and a rectangle. This can be done by drawing a line from each of the two vertices on the shorter parallel side to meet the longer parallel side at a right angle. The longer parallel side of the trapezoid breaks into pieces with lengths $a \text{ cm}$, 16 cm , and $36 - 16 - a = 20 - a \text{ cm}$. This is shown in the diagram.

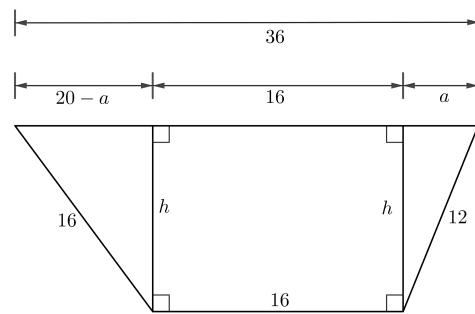

Using the Pythagorean Theorem, we can find two different expressions for h :

$$h = \sqrt{16^2 - (20-a)^2} \text{ and } h = \sqrt{12^2 - a^2}.$$

$$\text{Since } h = h, \sqrt{16^2 - (20-a)^2} = \sqrt{12^2 - a^2}.$$



Squaring both sides and expanding, we get $256 - 400 + 40a - a^2 = 144 - a^2$. Simplifying further, we get $40a = 288$, and so $a = 7.2$ cm.

Substituting $a = 7.2$ into $h = \sqrt{144 - a^2}$, we find that $h = \sqrt{144 - 7.2^2} = 9.6$ cm.

With both methods, we find that $h = 9.6$ cm. We now want to find the length of AB . Let DE represent the length of the longer parallel side of the back trapezoid, with C on DE such that $DC \perp BC$. It follows that $BC = h = 9.6$ cm.

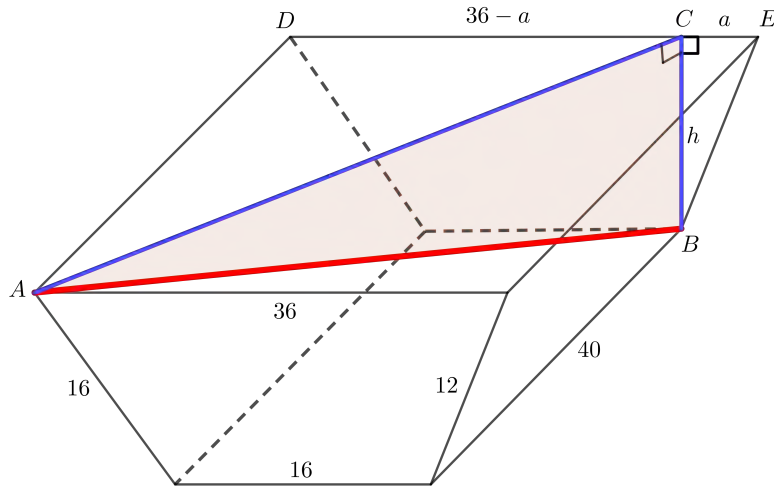

From Method 2, we know that $CE = a = 7.2$ cm. Then $DC = DE - CE = 36 - 7.2 = 28.8$ cm.

The sides of the prism are perpendicular to the ends, so $AD \perp DC$ and $\triangle CDA$ is a right-angled triangle. Using the Pythagorean Theorem in $\triangle CDA$,

$$\begin{aligned} AC^2 &= DC^2 + AD^2 \\ &= 28.8^2 + 40^2 \\ &= 2429.44 \end{aligned}$$

To find the required length, AB , we note that AC is a line segment drawn across the top of the prism. BC is a line segment perpendicular to the top and bottom of the prism. It follows that $\angle ACB = 90^\circ$ and $\triangle ACB$ is a right-angled triangle. We will use the Pythagorean Theorem in $\triangle ACB$ to find the length AB .

$$\begin{aligned} AB^2 &= AC^2 + BC^2 \\ &= 2429.44 + 9.6^2 \\ &= 2521.6 \end{aligned}$$

Since $AB > 0$, then we have $AB = \sqrt{2521.6} \approx 50.2$ cm.

Therefore, length of the body diagonal, AB , is approximately 50.2 cm.



Problem of the Week

Problem E

Three Squares

The three squares $ABCD$, $AEFG$, and $AHJK$ overlap as shown in the diagram.

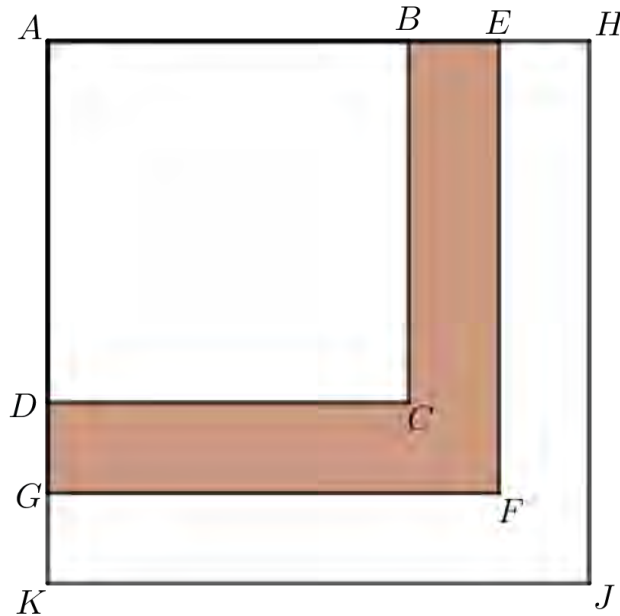

The side length of each square, in centimetres, is a positive integer. The area of square $AEFG$ that is not covered by square $ABCD$ is 33 cm^2 . That is, the area of the shaded region $BEFGDC$ is 33 cm^2 . If $DG = GK$, determine all possible side lengths of each square.



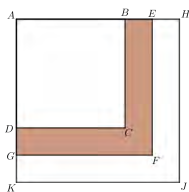

Problem of the Week

Problem E and Solution

Three Squares

Problem

The three squares $ABCD$, $AEFG$, and $AHJK$ overlap as shown in the diagram.

The side length of each square, in centimetres, is a positive integer. The area of square $AEFG$ that is not covered by square $ABCD$ is 33 cm^2 . That is, the area of the shaded region $BEFGDC$ is 33 cm^2 . If $DG = GK$, determine all possible side lengths of each square.

Solution

Let $AD = x \text{ cm}$ and $DG = y \text{ cm}$. Therefore $GK = DG = y \text{ cm}$.

Also, since the side length of each square is an integer, x and y are integers.

The shaded region has area 33 cm^2 . The shaded region is equal to the area of the square with side length AG minus the area of the square with side length AD .

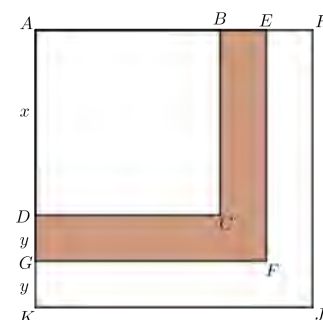

Since $AD = x$ and $AG = AD + DG = x + y$, we have

$$\begin{aligned} 33 &= (\text{area of square with side length } AG) - (\text{area of square with side length } AD) \\ &= (x + y)^2 - x^2 \\ &= x^2 + 2xy + y^2 - x^2 \\ &= 2xy + y^2 \\ &= y(2x + y) \end{aligned}$$

Since x and y are integers, so is $2x + y$. Therefore, $2x + y$ and y are two positive integers that multiply to give 33. Therefore, we must have $y = 1$ and $2x + y = 33$, or $y = 3$ and $2x + y = 11$, or $y = 11$ and $2x + y = 3$, or $y = 33$ and $2x + y = 1$. The last two would imply that $x < 0$, which is not possible. Therefore, $y = 1$ and $2x + y = 33$, or $y = 3$ and $2x + y = 11$.

When $y = 1$ and $2x + y = 33$, it follows that $x = 16$. Then square $ABCD$ has side length $x = 16 \text{ cm}$, square $AEFG$ has side length $x + y = 17 \text{ cm}$, and square $AHJK$ has side length $x + 2y = 18 \text{ cm}$.

When $y = 3$ and $2x + y = 11$, it follows that $x = 4$. Then square $ABCD$ has side length $x = 4 \text{ cm}$, square $AEFG$ has side length $x + y = 7 \text{ cm}$, and square $AHJK$ has side length $x + 2y = 10 \text{ cm}$.

Therefore, there are two possible sets of squares. The squares are either $16 \text{ cm} \times 16 \text{ cm}$ and $17 \text{ cm} \times 17 \text{ cm}$ and $18 \text{ cm} \times 18 \text{ cm}$, or $4 \text{ cm} \times 4 \text{ cm}$ and $7 \text{ cm} \times 7 \text{ cm}$ and $10 \text{ cm} \times 10 \text{ cm}$. Each of these sets of squares satisfies the conditions of the problem.



Problem of the Week

Problem E

A Square in a Triangle

In $\triangle ABC$, there is a right angle at B and the length of BC is twice the length of AB . In other words, $BC = 2AB$.

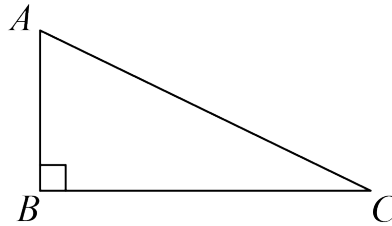

Square $DEFB$ is drawn inside $\triangle ABC$ so that vertex D is somewhere on AB between A and B , vertex E is somewhere on AC between A and C , vertex F is somewhere on BC between B and C , and the final vertex is at B .

Square $DEFB$ is called an *inscribed* square. Determine the ratio of the area of the inscribed square $DEFB$ to the area of $\triangle ABC$.



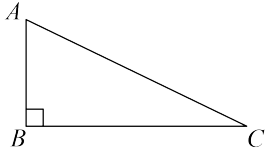

Problem of the Week

Problem E and Solution

A Square in a Triangle

Problem

In $\triangle ABC$, there is a right angle at B and the length of BC is twice the length of AB . In other words, $BC = 2AB$. Square $DEFB$ is drawn inside $\triangle ABC$ so that vertex D is somewhere on AB between A and B , vertex E is somewhere on AC between A and C , vertex F is somewhere on BC between B and C , and the final vertex is at B .

Square $DEFB$ is called an *inscribed* square. Determine the ratio of the area of the inscribed square $DEFB$ to the area of $\triangle ABC$.

Solution

First we draw square $DEFB$ according to the instructions in the problem. Let $DB = BF = FE = ED = a$ and $AD = b$. Since $BC = 2AB$, it follows that $BC = 2(AD + DB) = 2(a + b) = 2a + 2b$. Since $BC = BF + FC$, it follows that $2a + 2b = a + FC$, so $FC = a + 2b$.

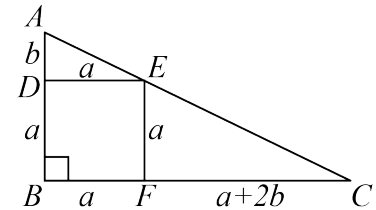

From here we present two solutions. In Solution 1, we solve the problem using similar triangles. In Solution 2, we place the diagram on the xy -plane and solve the problem using analytic geometry.

Solution 1

Consider $\triangle ADE$ and $\triangle ABC$. We will first show that $\triangle ADE \sim \triangle ABC$.

Since $DEFB$ is a square, then $\angle EDB = 90^\circ$, and so $\angle EDA = 180^\circ - \angle EDB = 180^\circ - 90^\circ = 90^\circ$. Therefore, $\angle EDA = \angle ABC$. Also, $\angle DAE = \angle BAC$ since they represent the same angle. Since the angles in a triangle add to 180° , then we must also have $\angle AED = \angle ACB$.

So $\triangle ADE \sim \triangle ABC$, by Angle-Angle-Angle Triangle Similarity.

Since $\triangle ADE \sim \triangle ABC$, then corresponding side lengths are in the same ratio. In particular,

$$\begin{aligned} \frac{AD}{DE} &= \frac{AB}{BC} \\ \frac{AD}{DE} &= \frac{AB}{2AB} \\ \frac{b}{a} &= \frac{1}{2} \\ a &= 2b \end{aligned}$$

Since $BC = 2a + 2b$ and $a = 2b$, then $BC = 2(2b) + 2b = 6b$. Since $AB = a + b$ and $a = 2b$, then $AB = 2b + b = 3b$. The area of $\triangle ABC$ is $\frac{1}{2}(BC \times AB) = \frac{1}{2}(6b \times 3b) = 9b^2$.

The area of square $DEFB$ is $a \times a = a^2 = (2b)^2 = 4b^2$.

The ratio of the area of inscribed square $DEFB$ to the area of $\triangle ABC$ is $4b^2 : 9b^2 = 4 : 9$, since $b > 0$.



Solution 2

First we place the triangle on the xy -plane with B at $(0,0)$ and BC along the positive x -axis. The coordinates of D are $(0,a)$, the coordinates of A are $(0,a+b)$, the coordinates of F are $(a,0)$, the coordinates of E are (a,a) , and the coordinates of C are $(2a+2b,0)$.

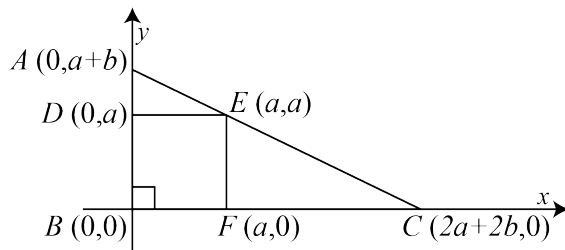

Let's determine the equation of the line through A , E , and C .

Since this line passes through $(0, a+b)$, then we know it has y -intercept $a+b$.

Since it passes through $(0, a+b)$ and (a, a) , then the line has slope $\frac{a-(a+b)}{a-0} = -\frac{b}{a}$.

Therefore, the equation of the line through A , E , and C is $y = \left(-\frac{b}{a}\right)x + a + b$.

Since $C(2a+2b,0)$ lies on this line, then substituting $x = 2a+2b$ and $y = 0$ into $y = \left(-\frac{b}{a}\right)x + a + b$ gives

$$\begin{aligned} 0 &= \left(-\frac{b}{a}\right)(2a+2b) + a + b \\ 0 &= (-b)(2a+2b) + (a)(a+b) \\ 0 &= -2ab - 2b^2 + a^2 + ab \\ 0 &= a^2 - ab - 2b^2 \\ 0 &= (a+b)(a-2b) \end{aligned}$$

Thus, $a = -b$ or $a = 2b$. But since $a, b > 0$, then $a = -b$ is inadmissible and we must have $a = 2b$.

Since $BC = 2a+2b$ and $a = 2b$, then $BC = 2(2b)+2b = 6b$. Since $AB = a+b$ and $a = 2b$, then $AB = 2b+b = 3b$. The area of $\triangle ABC$ is $\frac{1}{2}(BC \times AB) = \frac{1}{2}(6b \times 3b) = 9b^2$.

The area of square $DEFB$ is $a \times a = a^2 = (2b)^2 = 4b^2$.

The ratio of the area of inscribed square $DEFB$ to the area of $\triangle ABC$ is $4b^2 : 9b^2 = 4 : 9$, since $b > 0$.

NOTE:

From the equation $0 = (-b)(2a+2b) + (a)(a+b)$, we could have instead factored $(2a+2b)$ to obtain $0 = (-2b)(a+b) + a(a+b)$. Since $a, b > 0$, $a+b > 0$, so we could have divided out the common factor of $(a+b)$ leaving $0 = -2b + a$ which simplifies to $a = 2b$. Thus, the factoring of $a^2 - ab - 2b^2$ to determine $a = 2b$ would not have been necessary.

EXTENSION:

If, in the original problem, $BC = kAB$, where $k > 0$, and the square was inscribed as given, what would be the ratio of the area of square $DEFB$ to the area of $\triangle ABC$?



Problem of the Week

Problem E

Only One

A circle with centre O and radius 4 has points A and B on its circumference such that $\angle AOB = 90^\circ$.

Another circle with diameter AB is drawn such that O lies on its circumference.

Find the area of the shaded region, which is the area inside one circle or the other circle, but not both.

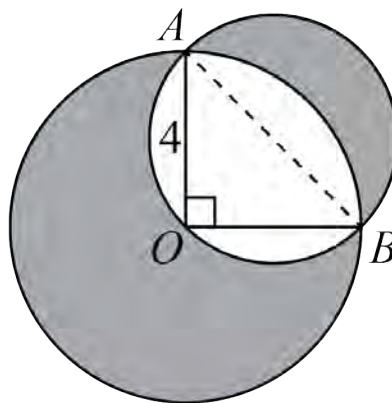

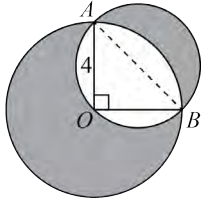

Problem of the Week

Problem E and Solution

Only One

Problem

A circle with centre O and radius 4 has points A and B on its circumference such that $\angle AOB = 90^\circ$.

Another circle with diameter AB is drawn such that O lies on its circumference.

Find the area of the shaded region, which is the area inside one circle or the other circle, but not both.

Solution

Let A_1 be the region inside the larger circle but outside the smaller circle.

Let A_2 be the region inside the smaller circle but outside the larger circle.

Let A_3 be the region inside sector AOB but outside of $\triangle AOB$.

We need to calculate $A_1 + A_2$.

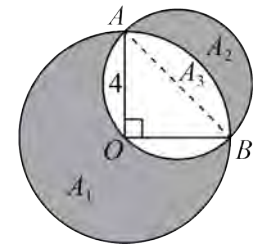

First, we will calculate A_3 .

Since $\angle AOB = 90^\circ$, the area of sector AOB is $\frac{90}{360} = \frac{1}{4}$ the area of the larger circle.

That is, the area of sector AOB is $\frac{1}{4} \times \pi(4)^2 = 4\pi$.

The area of $\triangle AOB$ is $\frac{1}{2}(OA)(OB) = \frac{1}{2}(4)(4) = 8$.

Therefore, $A_3 = \text{area of sector } AOB - \text{area of } \triangle AOB = (4\pi - 8)$.

Next we will calculate A_2 .

Since $\angle AOB = 90^\circ$, the Pythagorean theorem tells us $AB^2 = OA^2 + OB^2 = 4^2 + 4^2 = 32$.

Therefore, $AB = \sqrt{32} = 4\sqrt{2}$, since $AB > 0$.

Since AB is a diameter of the smaller circle, the radius is $\frac{1}{2}AB = \frac{1}{2}(4\sqrt{2}) = 2\sqrt{2}$.

Therefore, $A_2 + A_3 = \frac{1}{2}(\text{the area of the circle with radius } 2\sqrt{2}) = \frac{1}{2}\pi(2\sqrt{2})^2 = \frac{1}{2}\pi(8) = 4\pi$.

Therefore, $A_2 = 4\pi - A_3 = 4\pi - (4\pi - 8) = 8$.

Finally, we will calculate A_1 .

A_1 represents the area inside the larger circle which is not in the smaller circle.

The larger circle has radius 4 and area $\pi(4)^2 = 16\pi$.

The smaller circle has radius $2\sqrt{2}$ and area $\pi(2\sqrt{2})^2 = 8\pi$.

$$\begin{aligned} A_1 &= (\text{area of larger circle}) - \frac{1}{2}(\text{area of smaller circle}) - A_3 \\ &= 16\pi - \frac{1}{2}(8\pi) - (4\pi - 8) \\ &= 16\pi - 4\pi - 4\pi + 8 \\ &= 8\pi + 8 \end{aligned}$$

Therefore, the area of the shaded region is equal to $A_1 + A_2 = (8\pi + 8) + 8 = (8\pi + 16)$ units².



Problem of the Week

Problem E

A Dividing Point

A square has vertices at $A(0, 0)$, $B(-9, 12)$, $C(3, 21)$, and $D(12, 9)$.

The line ℓ passes through A and intersects CD at point $T(r, s)$, splitting the square so that the area of square $ABCD$ is three times the area of $\triangle ATD$.

Determine the equation of line ℓ .

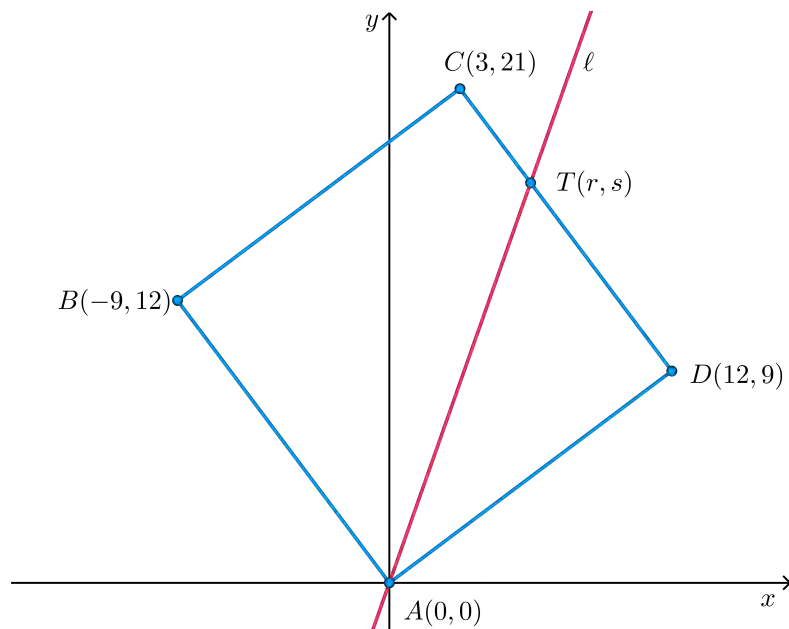



Problem of the Week

Problem E and Solution

A Dividing Point

Problem

A square has vertices at $A(0, 0)$, $B(-9, 12)$, $C(3, 21)$, and $D(12, 9)$.

The line ℓ passes through A and intersects CD at point $T(r, s)$, splitting the square so that the area of square $ABCD$ is three times the area of $\triangle ATD$.

Determine the equation of line ℓ .

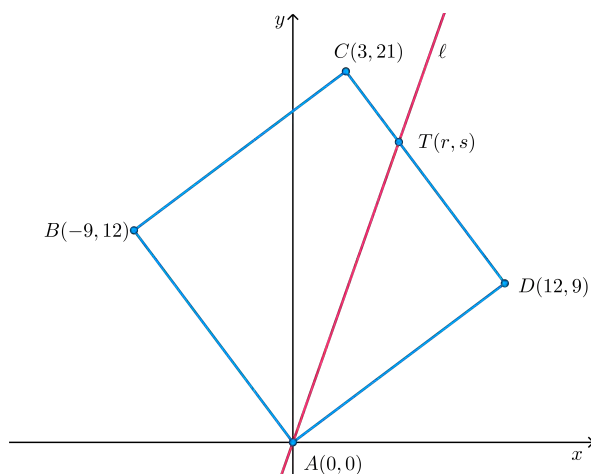

Solution

Since A has coordinates $(0, 0)$ and D has coordinates $(12, 9)$, using the distance formula, we have

$$\begin{aligned}AD &= \sqrt{(9 - 0)^2 + (12 - 0)^2} \\ &= \sqrt{81 + 144} \\ &= \sqrt{225} \\ &= 15\end{aligned}$$

Therefore, the area of square $ABCD$ is equal to $15^2 = 225$.

Since the area of square $ABCD$ is three times the area of $\triangle ATD$, the area of $\triangle ATD$ is equal to $\frac{1}{3}$ of the area of square $ABCD$. Thus, the area of $\triangle ATD = \frac{1}{3}(225) = 75$.

Since $ABCD$ is a square, $\angle ADC = 90^\circ$. Consider $\triangle ATD$. This triangle is a right-angled triangle with base $AD = 15$ and height TD .

Using the formula $\text{area} = \frac{\text{base} \times \text{height}}{2}$,

$$\begin{aligned}\text{area of } \triangle ATD &= \frac{AD \times TD}{2} \\ 75 &= \frac{15 \times TD}{2} \\ TD &= 10\end{aligned}$$

From here we present two solutions.



Solution 1

We first calculate the equation of the line that the segment CD lies on.

Since D has coordinates $(12, 9)$ and C has coordinates $(3, 21)$, this line has slope equal to $\frac{21-9}{3-12} = \frac{12}{-9} = -\frac{4}{3}$.

Since the line has slope $-\frac{4}{3}$ and the point $(3, 21)$ lies on the line, we have

$$\begin{aligned}\frac{y-21}{x-3} &= -\frac{4}{3} \\ 3y-63 &= -4x+12 \\ 3y &= -4x+75 \\ y &= -\frac{4}{3}x+25\end{aligned}$$

Since $T(r, s)$ lies on this line, $s = -\frac{4}{3}r + 25$.

Using the distance formula, since T has coordinates (r, s) , D has coordinates $(12, 9)$, and $TD = 10$, we have

$$\begin{aligned}\sqrt{(r-12)^2 + (s-9)^2} &= 10 \\ (r-12)^2 + (s-9)^2 &= 100\end{aligned}$$

Since $s = -\frac{4}{3}r + 25$, we have

$$\begin{aligned}(r-12)^2 + \left(\left(-\frac{4}{3}r+25\right)-9\right)^2 &= 100 \\ (r-12)^2 + \left(-\frac{4}{3}r+16\right)^2 &= 100 \\ r^2 - 24r + 144 + \frac{16}{9}r^2 - \frac{128}{3}r + 256 &= 100 \\ \frac{25}{9}r^2 - \frac{200}{3}r + 300 &= 0 \\ \frac{25}{9}(r^2 - 24r + 108) &= 0 \\ r^2 - 24r + 108 &= 0 \\ (r-6)(r-18) &= 0 \\ r &= 6, 18\end{aligned}$$

But $r = 18$ lies outside the square. Therefore, $r = 6$ and $s = -\frac{4}{3}(6) + 25 = -8 + 25 = 17$.

Thus, the line ℓ passes through $A(0, 0)$ and $T(6, 17)$, has y -intercept 0, and slope $\frac{17-0}{6-0} = \frac{17}{6}$.

Therefore, the equation of line ℓ is $y = \frac{17}{6}x$, or $17x - 6y = 0$.



Solution 2

Since $TD = 10$ and $CD = 15$, we have $CT = CD - TD = 15 - 10 = 5$.

Since $\triangle ATD$ is a right-angled triangle, using the Pythagorean Theorem we have

$$\begin{aligned}AT^2 &= AD^2 + TD^2 \\(r - 0)^2 + (s - 0)^2 &= 15^2 + 10^2 \\r^2 + s^2 &= 325\end{aligned}$$

Since T has coordinates (r, s) , C has coordinates $(3, 21)$, and $CT = 5$, using the distance formula we have

$$\begin{aligned}5 &= \sqrt{(r - 3)^2 + (s - 21)^2} \\25 &= r^2 - 6r + 9 + s^2 - 42s + 441 \\6r + 42s &= r^2 + s^2 + 425\end{aligned}$$

Since $r^2 + s^2 = 325$, we have

$$\begin{aligned}6r + 42s &= 325 + 425 \\&= 750\end{aligned}$$

Again, since T has coordinates (r, s) , D has coordinates $(12, 9)$, and $TD = 10$, using the distance formula we have

$$\begin{aligned}10 &= \sqrt{(r - 12)^2 + (s - 9)^2} \\100 &= r^2 - 24r + 144 + s^2 - 18s + 81 \\24r + 18s &= r^2 + s^2 + 125\end{aligned}$$

Since $r^2 + s^2 = 325$, we have

$$\begin{aligned}24r + 18s &= 325 + 125 \\&= 450\end{aligned}$$

We now have the system of equations

$$\begin{aligned}6r + 42s &= 750 \\24r + 18s &= 450\end{aligned}$$

Multiplying the first equation by 4, we get the system

$$\begin{aligned}24r + 168s &= 3000 \\24r + 18s &= 450\end{aligned}$$

Subtracting the second equation from the first gives $150s = 2550$, and $s = 17$ follows. Substituting $s = 17$ into $6r + 42s = 750$, we obtain $6r + 42(17) = 750$, and $r = 6$ follows.

Thus, the line ℓ passes through $A(0, 0)$ and $T(6, 17)$, has y -intercept 0, and slope $\frac{17 - 0}{6 - 0} = \frac{17}{6}$.

Therefore, the equation of line ℓ is $y = \frac{17}{6}x$, or $17x - 6y = 0$.

EXTENSION:

Can you determine the coordinates of point U on CB such that the area of $\triangle ABU$ is equal to the area of $\triangle ATD$? By finding U and T , you will have found two line segments, AU and AT , that divide square $ABCD$ into three regions of equal area.

Algebra (A)





Problem of the Week

Problem E

How Many?

Natalia has a jar containing some number magnets. In the jar there is one set of numbers from 1 to 9, as well as some extra number 5 magnets and number 8 magnets. If the mean (average) of all the numbers in the jar is 6.4, what is the smallest possible number of number magnets in the jar?





Problem of the Week

Problem E and Solution

How Many?

Problem

Natalia has a jar containing some number magnets. In the jar there is one set of numbers from 1 to 9, as well as some extra number 5 magnets and number 8 magnets. If the mean (average) of all the numbers in the jar is 6.4, what is the smallest possible number of number magnets in the jar?

Solution

Let m be the number of extra number 5 magnets and n be the number of extra number 8 magnets in the jar, where both m and n are positive integers.

It follows that there are a total of $(9 + m + n)$ number magnets in the jar. The sum of the numbers in the jar is $(1 + 2 + 3 + \cdots + 7 + 8 + 9 + 5m + 8n)$ which simplifies to $(45 + 5m + 8n)$.

The mean (average) of a set of values is equal to the sum of the values in the set divided by the number of values in the set. Since the average of all the numbers in the jar is 6.4, we can write the following equation.

$$\begin{aligned}\frac{45 + 5m + 8n}{9 + m + n} &= 6.4 \\ \frac{450 + 50m + 80n}{9 + m + n} &= 64 \\ 450 + 50m + 80n &= 64(9 + m + n) \\ 450 + 50m + 80n &= 576 + 64m + 64n \\ 16n - 14m &= 126 \\ 8n &= 63 + 7m \\ n &= \frac{7(9 + m)}{8}\end{aligned}$$

Since m and n are positive integers, $7(9 + m)$ must be divisible by 8. Since 7 is not a multiple of 8, it follows that $(9 + m)$ must be a multiple of 8.

Since m is a positive integer, $(9 + m)$ must be greater than 9. The smallest multiple of 8 which is also greater than 9 is 16. Therefore, $9 + m = 16$ and $m = 7$. Then we can solve for n .

$$n = \frac{7(9 + m)}{8} = \frac{7(16)}{8} = 14$$

Therefore, the smallest number of number magnets in the jar is $9 + 7 + 14 = 30$. It is left as an exercise for the solver to verify that this produces the correct average.

EXTENSION:

Determine the *largest* number of number magnets less than 1000 that could be in the jar, if their mean is 6.4.



Problem of the Week

Problem E

Painting is Fund (Raising)

The POTW High School Painting Club has 30 student members, some from Grade 11 and the remainder from Grade 12. Over the year, they want to fundraise money for the school art department. Each possible pairing of students from the club will create exactly one painting together. When two Grade 11 students paint together, they will sell the painting for \$20. When a Grade 11 and a Grade 12 student paint together, they will sell the painting for \$30. When two Grade 12 students paint together, they will sell the painting for \$40.

When all the paintings are sold, the students will have raised \$13 920. How many of the 30 members of the club are Grade 11 students?





Problem of the Week

Problem E and Solution

Painting is Fund (Raising)

Problem

The POTW High School Painting Club has 30 student members, some from Grade 11 and the remainder from Grade 12. Over the year, they want to fundraise money for the school art department. Each possible pairing of students from the club will create exactly one painting together. When two Grade 11 students paint together, they will sell the painting for \$20. When a Grade 11 and a Grade 12 student paint together, they will sell the painting for \$30. When two Grade 12 students paint together, they will sell the painting for \$40.

When all the paintings are sold, the students will have raised \$13 920. How many of the 30 members of the club are Grade 11 students?

Solution

If 3 students, Student A , Student B , and Student C , are in the same grade, then there will be $(3 \times 2) \div 2 = 3$ pairings, namely AB , AC , and BC . (If we look at this using a counting argument, there would be 3 choices for the first student and for each of these choices, there would be 2 choices for the second student, a total of $3 \times 2 = 6$ pairings, namely AB , AC , BA , BC , CA , and CB . However, notice that each pairing appears twice. Since order is not important we must divide by 2, getting us 3 possible pairings.)

If 3 students, Student A , Student B , and Student C , are in Grade 11 and 2 students, Student D and Student E , are in Grade 12, then there will be $3 \times 2 = 6$ pairings of students in different grades, namely AD , AE , BD , BE , CD , and CE . (There are 3 choices for the Grade 11 student in the pairing and for each of these choices, there are 2 possibilities for the Grade 12 student. This gives a total of $3 \times 2 = 6$ pairings.)

Similar arguments will now be applied to our problem.

Let a represent the number of Grade 11 students in the club and $(30 - a)$ represent the number of Grade 12 students in the club.

Since there are a students in Grade 11 and each must paint with every other student in Grade 11, there will be $a \times (a - 1) \div 2$ paintings from pairs where both students are in Grade 11. Thus, the amount raised by paintings from pairs where both students are in Grade 11 would be

$$20 \times \left(\frac{a(a - 1)}{2} \right)$$



Similarly, since there are $(30 - a)$ students in Grade 12 and each must paint with every other student in Grade 12, there will be

$(30 - a) \times (30 - a - 1) \div 2 = (30 - a) \times (29 - a) \div 2$ paintings from pairs where both students are in Grade 12. Thus, the amount raised by paintings from pairs where both students are in Grade 12 would be

$$40 \times \left(\frac{(30 - a)(29 - a)}{2} \right)$$

Since every Grade 11 student must paint with every Grade 12 student, there will be $a \times (30 - a)$ paintings from pairs with one student from each grade. Thus, the amount raised by paintings from pairs with one student from each grade would be

$$30 \times (a(30 - a))$$

Therefore,

$$13\,920 = 20 \left(\frac{a(a - 1)}{2} \right) + 40 \left(\frac{(30 - a)(29 - a)}{2} \right) + 30(a(30 - a))$$

$$13\,920 = 10(a^2 - a) + 20(870 - 59a + a^2) + 30(30a - a^2)$$

$$1392 = (a^2 - a) + 2(870 - 59a + a^2) + 3(30a - a^2)$$

$$1392 = a^2 - a + 1740 - 118a + 2a^2 + 90a - 3a^2$$

$$1392 = -29a + 1740$$

$$29a = 348$$

$$a = 12$$

Therefore, 12 of the students in the club are in Grade 11.



Problem of the Week

Problem E

Keeping it Small

Clara is learning to code, so she has written a program to help her practice what she has learned so far.

Clara's program takes two real numbers as input, called A and B . First, her program doubles A , squares the result, and then reduces this result by four times A . The result is called C . Then her program squares B , and then increases this result by six times B . The result is called D . Finally, her program outputs the sum of C and D .

Determine the minimum possible output of Clara's program, and the two input values that produce this output.

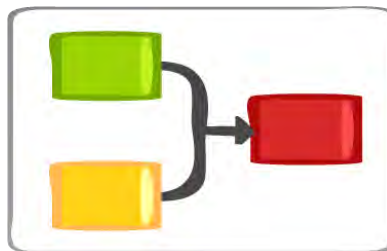

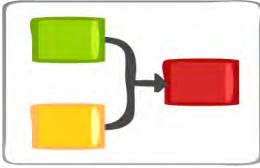

Problem of the Week

Problem E and Solution

Keeping it Small

Problem

Clara is learning to code, so she has written a program to help her practice what she has learned so far.

Clara's program takes two real numbers as input, called A and B . First, her program doubles A , squares the result, and then reduces this result by four times A . The result is called C . Then her program squares B , and then increases this result by six times B . The result is called D . Finally, her program outputs the sum of C and D .

Determine the minimum possible output of Clara's program, and the two input values that produce this output.

Solution

In order to minimize the final output, we need to minimize both C and D .

First, let's minimize C . Clara's program doubles A to get $2A$. It squares this result to get $(2A)^2 = 4A^2$. It then reduces this number by $4A$, to get $C = 4A^2 - 4A$. Thus, we need to minimize $4A^2 - 4A$. This is a quadratic and so represents a parabola. Since the coefficient of A^2 is positive, it opens up and so its minimum value occurs at its vertex. We can find the vertex by completing the square.

$$\begin{aligned}4A^2 - 4A &= 4(A^2 - A) \\ &= 4\left(A^2 - A + \frac{1}{4} - \frac{1}{4}\right) \\ &= 4\left(A^2 - A + \frac{1}{4}\right) - 1 \\ &= 4\left(A - \frac{1}{2}\right)^2 - 1\end{aligned}$$

The vertex is at $\left(\frac{1}{2}, -1\right)$, and so the minimum value of $C = 4A^2 - 4A$ is -1 and occurs when $A = \frac{1}{2}$.

Now let's minimize D . Clara's program squares B to get B^2 . It then increases the result by $6B$ to get $D = B^2 + 6B$. So we need to minimize $B^2 + 6B$. This is a quadratic and so represents a parabola. Since the coefficient of B^2 is positive, it opens up and so its minimum value occurs at its vertex. We can find the vertex by completing the square.

$$\begin{aligned}B^2 + 6B &= (B^2 + 6B + 9) - 9 \\ &= (B + 3)^2 - 9\end{aligned}$$

The vertex is at $(-3, -9)$, and so the minimum value of $D = B^2 + 6B$ is -9 and occurs when $B = -3$.

Therefore, the minimum possible output of Clara's program is $-1 + (-9) = -10$ and occurs when $A = \frac{1}{2}$ and $B = -3$.

Aside: This problem is essentially asking us to minimize the multivariable function $f(x, y) = 4x^2 - 4x + y^2 + 6y$.



Problem of the Week

Problem E

One More Coin

A coin collecting club has between 12 and 30 members attend its monthly meeting. For one such meeting, they noticed that all of the members present each had the same number of coins except one member who had one more coin than each of the other members. Between them, the members had a total number of 1000 coins.

How many members attended the meeting?





Problem of the Week

Problem E and Solution

One More Coin

Problem

A coin collecting club has between 12 and 30 members attend its monthly meeting. For one such meeting, they noticed that all of the members present each had the same number of coins except one member who had one more coin than each of the other members. Between them, the members had a total number of 1000 coins.

How many members attended the meeting?

Solution

Let n represent the number of members present at the meeting. We know that $12 < n < 30$ and n is an integer. Let c represent the number of coins that all but one member had. That member had $c + 1$ coins. It follows that $(n - 1)$ members had c coins each and one member had $c + 1$ coins, producing a total of 1000 coins.

Thus,

$$\begin{aligned}(n - 1) \times c + 1 \times (c + 1) &= 1000 \\ nc - c + c + 1 &= 1000 \\ nc &= 999\end{aligned}$$

We are looking for two positive integers with a product of 999, with one of the numbers between 12 and 30. The prime factorization of 999 is $3 \times 3 \times 3 \times 37$. We can combine the factors to produce pairs of positive integers whose product is 999. The possibilities are 1 and 999, 3 and 333, 9 and 111, and 27 and 37. The only possible product which gives one factor between 12 and 30 is 27×37 .

It follows that there were 27 members present at the last meeting, and 26 of the members had 37 coins each and 1 member had 38 coins. This can be easily verified, as $26 \times 37 + 1 \times 38 = 1000$.



Problem of the Week

Problem E

Three Squares

The three squares $ABCD$, $AEFG$, and $AHJK$ overlap as shown in the diagram.

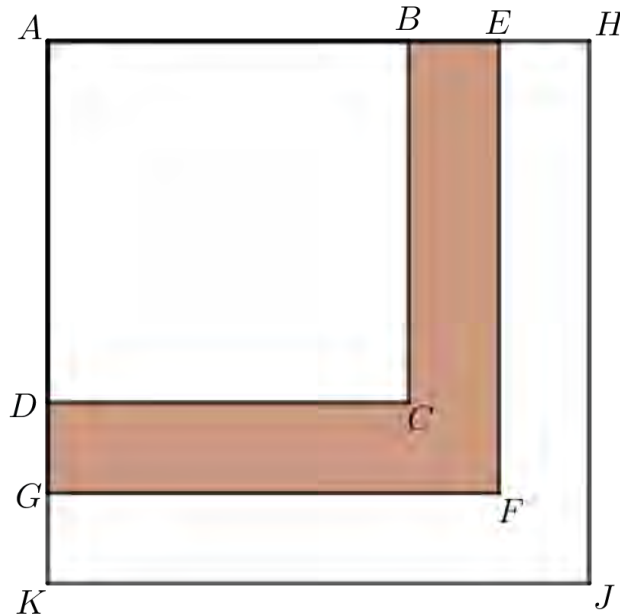

The side length of each square, in centimetres, is a positive integer. The area of square $AEFG$ that is not covered by square $ABCD$ is 33 cm^2 . That is, the area of the shaded region $BEFGDC$ is 33 cm^2 . If $DG = GK$, determine all possible side lengths of each square.



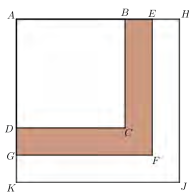

Problem of the Week

Problem E and Solution

Three Squares

Problem

The three squares $ABCD$, $AEFG$, and $AHJK$ overlap as shown in the diagram.

The side length of each square, in centimetres, is a positive integer. The area of square $AEFG$ that is not covered by square $ABCD$ is 33 cm^2 . That is, the area of the shaded region $BEFGDC$ is 33 cm^2 . If $DG = GK$, determine all possible side lengths of each square.

Solution

Let $AD = x \text{ cm}$ and $DG = y \text{ cm}$. Therefore $GK = DG = y \text{ cm}$. Also, since the side length of each square is an integer, x and y are integers.

The shaded region has area 33 cm^2 . The shaded region is equal to the area of the square with side length AG minus the area of the square with side length AD .

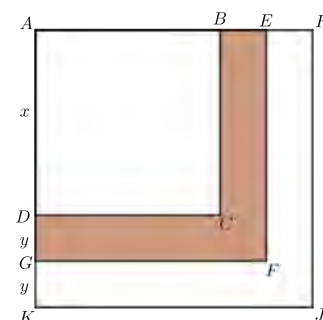

Since $AD = x$ and $AG = AD + DG = x + y$, we have

$$\begin{aligned} 33 &= (\text{area of square with side length } AG) - (\text{area of square with side length } AD) \\ &= (x + y)^2 - x^2 \\ &= x^2 + 2xy + y^2 - x^2 \\ &= 2xy + y^2 \\ &= y(2x + y) \end{aligned}$$

Since x and y are integers, so is $2x + y$. Therefore, $2x + y$ and y are two positive integers that multiply to give 33. Therefore, we must have $y = 1$ and $2x + y = 33$, or $y = 3$ and $2x + y = 11$, or $y = 11$ and $2x + y = 3$, or $y = 33$ and $2x + y = 1$. The last two would imply that $x < 0$, which is not possible. Therefore, $y = 1$ and $2x + y = 33$, or $y = 3$ and $2x + y = 11$.

When $y = 1$ and $2x + y = 33$, it follows that $x = 16$. Then square $ABCD$ has side length $x = 16 \text{ cm}$, square $AEFG$ has side length $x + y = 17 \text{ cm}$, and square $AHJK$ has side length $x + 2y = 18 \text{ cm}$.

When $y = 3$ and $2x + y = 11$, it follows that $x = 4$. Then square $ABCD$ has side length $x = 4 \text{ cm}$, square $AEFG$ has side length $x + y = 7 \text{ cm}$, and square $AHJK$ has side length $x + 2y = 10 \text{ cm}$.

Therefore, there are two possible sets of squares. The squares are either $16 \text{ cm} \times 16 \text{ cm}$ and $17 \text{ cm} \times 17 \text{ cm}$ and $18 \text{ cm} \times 18 \text{ cm}$, or $4 \text{ cm} \times 4 \text{ cm}$ and $7 \text{ cm} \times 7 \text{ cm}$ and $10 \text{ cm} \times 10 \text{ cm}$. Each of these sets of squares satisfies the conditions of the problem.



Problem of the Week

Problem E

A Pinch of Salt?

A container initially contained 320 grams of common salt.

Mixture Y was formed by taking x grams of the common salt out of the container, adding x grams of Himalayan Pink Salt to the container, and then mixing uniformly. In Mixture Y, the ratio of the mass of the common salt to the mass of the Himalayan Pink Salt, expressed in lowest terms, was $c : h$.

Mixture Z was then formed by taking x grams of Mixture Y out of the container, adding x grams of Himalayan Pink Salt to the container, and then mixing uniformly. In Mixture Z, the ratio of the mass of the common salt to the mass of the Himalayan Pink Salt was $49 : 15$.

What is the value of $x + c + h$?





Problem of the Week

Problem E and Solution

A Pinch of Salt?

Problem

A container initially contained 320 grams of common salt.

Mixture Y was formed by taking x grams of the common salt out of the container, adding x grams of Himalayan Pink Salt to the container, and then mixing uniformly. In Mixture Y, the ratio of the mass of the common salt to the mass of the Himalayan Pink Salt, expressed in lowest terms, was $c : h$.

Mixture Z was then formed by taking x grams of Mixture Y out of the container, adding x grams of Himalayan Pink Salt to the container, and then mixing uniformly. In Mixture Z, the ratio of the mass of the common salt to the mass of the Himalayan Pink Salt was $49 : 15$.

What is the value of $x + c + h$?

Solution

Initially, the container contained 320 g of common salt and 0 g of Himalayan Pink Salt.

Mixture Y contained $(320 - x)$ g of common salt and x g of Himalayan Pink Salt. When Mixture Z (the final mixture) is formed, there was still a total of 320 g of salt in the bowl.

In Mixture Z, the ratio of the mass of common salt to the mass of Himalayan Pink Salt is $49 : 15$. Therefore, the mass of common salt is $\frac{49}{49+15} \cdot 320 = \frac{49}{64} \cdot 320 = 49 \cdot 5 = 245$ g and the mass of Himalayan Pink Salt in Mixture Z is $320 - 245 = 75$ g.

Mixture Y consisted of $(320 - x)$ g of common salt and x g of Himalayan Pink Salt, which were thoroughly mixed together. Therefore, each gram of Mixture Y consisted of $\frac{320-x}{320}$ g of common salt and $\frac{x}{320}$ g of Himalayan Pink Salt.

To form Mixture Z, x g of Mixture Y was removed. This amount of Mixture Y that was removed contained $x \cdot \frac{x}{320} = \frac{x^2}{320}$ g of Himalayan Pink Salt. Therefore, the mass of Himalayan Pink Salt in Mixture Z is the original x g added to get Mixture Y minus the $\frac{x^2}{320}$ g from mixture Y plus the new x g making $x - \frac{x^2}{320} + x = 2x - \frac{x^2}{320}$ g of Himalayan Pink Salt.

But we determined earlier that Mixture Z contains 75 g of Himalayan Pink Salt. Therefore,

$$\begin{aligned}2x - \frac{x^2}{320} &= 75 \\0 &= x^2 - 2(320)x + 75(320) \\0 &= x^2 - 640x + 24\,000 \\0 &= (x - 40)(x - 600)\end{aligned}$$

Therefore, $x = 40$ or $x = 600$.

Since the initial mixture consisted of 320 g of common salt, then we must have $x < 320$. It follows that $x = 40$.

Therefore, Mixture Y consisted of $320 - 40 = 280$ g of common salt and 40 g of Himalayan Pink Salt. The ratio of these masses is $280 : 40$ or $7 : 1$ in lowest terms. Thus, $c = 7$ and $h = 1$.

Therefore, $x + c + h = 40 + 7 + 1 = 48$.



Problem of the Week

Problem E

A Dividing Point

A square has vertices at $A(0, 0)$, $B(-9, 12)$, $C(3, 21)$, and $D(12, 9)$.

The line ℓ passes through A and intersects CD at point $T(r, s)$, splitting the square so that the area of square $ABCD$ is three times the area of $\triangle ATD$.

Determine the equation of line ℓ .

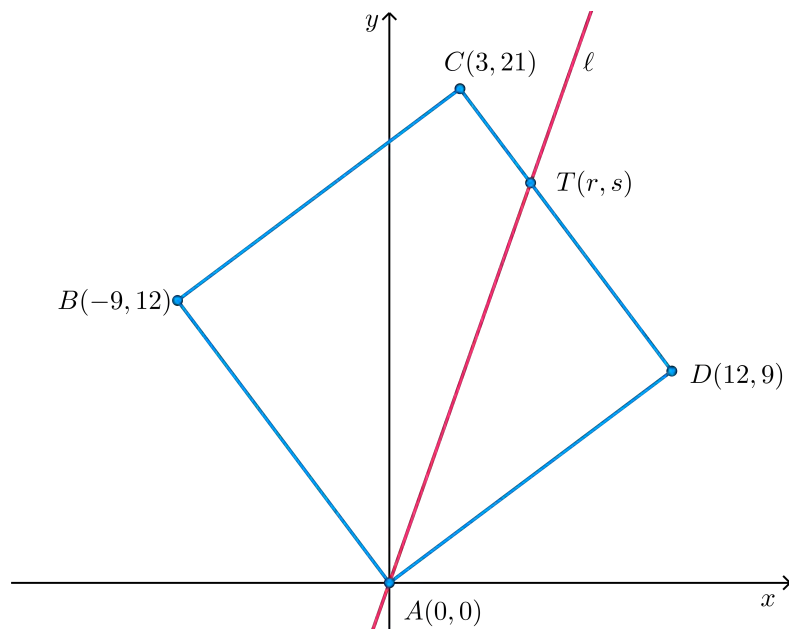



Problem of the Week

Problem E and Solution

A Dividing Point

Problem

A square has vertices at $A(0, 0)$, $B(-9, 12)$, $C(3, 21)$, and $D(12, 9)$.

The line ℓ passes through A and intersects CD at point $T(r, s)$, splitting the square so that the area of square $ABCD$ is three times the area of $\triangle ATD$.

Determine the equation of line ℓ .

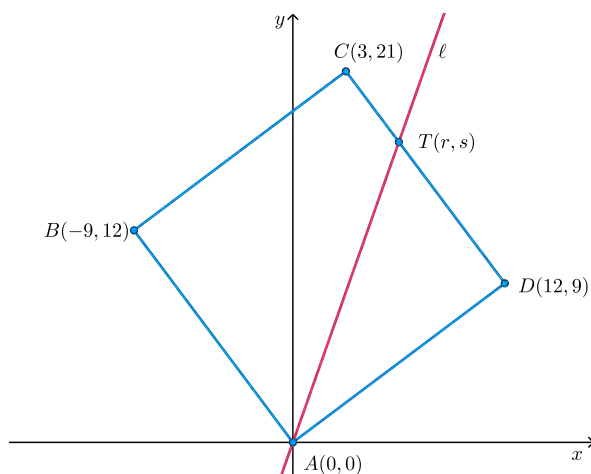

Solution

Since A has coordinates $(0, 0)$ and D has coordinates $(12, 9)$, using the distance formula, we have

$$\begin{aligned}AD &= \sqrt{(9 - 0)^2 + (12 - 0)^2} \\ &= \sqrt{81 + 144} \\ &= \sqrt{225} \\ &= 15\end{aligned}$$

Therefore, the area of square $ABCD$ is equal to $15^2 = 225$.

Since the area of square $ABCD$ is three times the area of $\triangle ATD$, the area of $\triangle ATD$ is equal to $\frac{1}{3}$ of the area of square $ABCD$. Thus, the area of $\triangle ATD = \frac{1}{3}(225) = 75$.

Since $ABCD$ is a square, $\angle ADC = 90^\circ$. Consider $\triangle ATD$. This triangle is a right-angled triangle with base $AD = 15$ and height TD .

Using the formula $\text{area} = \frac{\text{base} \times \text{height}}{2}$,

$$\begin{aligned}\text{area of } \triangle ATD &= \frac{AD \times TD}{2} \\ 75 &= \frac{15 \times TD}{2} \\ TD &= 10\end{aligned}$$

From here we present two solutions.



Solution 1

We first calculate the equation of the line that the segment CD lies on.

Since D has coordinates $(12, 9)$ and C has coordinates $(3, 21)$, this line has slope equal to $\frac{21-9}{3-12} = \frac{12}{-9} = -\frac{4}{3}$.

Since the line has slope $-\frac{4}{3}$ and the point $(3, 21)$ lies on the line, we have

$$\begin{aligned}\frac{y-21}{x-3} &= -\frac{4}{3} \\ 3y-63 &= -4x+12 \\ 3y &= -4x+75 \\ y &= -\frac{4}{3}x+25\end{aligned}$$

Since $T(r, s)$ lies on this line, $s = -\frac{4}{3}r + 25$.

Using the distance formula, since T has coordinates (r, s) , D has coordinates $(12, 9)$, and $TD = 10$, we have

$$\begin{aligned}\sqrt{(r-12)^2 + (s-9)^2} &= 10 \\ (r-12)^2 + (s-9)^2 &= 100\end{aligned}$$

Since $s = -\frac{4}{3}r + 25$, we have

$$\begin{aligned}(r-12)^2 + \left(\left(-\frac{4}{3}r+25\right)-9\right)^2 &= 100 \\ (r-12)^2 + \left(-\frac{4}{3}r+16\right)^2 &= 100 \\ r^2 - 24r + 144 + \frac{16}{9}r^2 - \frac{128}{3}r + 256 &= 100 \\ \frac{25}{9}r^2 - \frac{200}{3}r + 300 &= 0 \\ \frac{25}{9}(r^2 - 24r + 108) &= 0 \\ r^2 - 24r + 108 &= 0 \\ (r-6)(r-18) &= 0 \\ r &= 6, 18\end{aligned}$$

But $r = 18$ lies outside the square. Therefore, $r = 6$ and $s = -\frac{4}{3}(6) + 25 = -8 + 25 = 17$.

Thus, the line ℓ passes through $A(0, 0)$ and $T(6, 17)$, has y -intercept 0, and slope $\frac{17-0}{6-0} = \frac{17}{6}$.

Therefore, the equation of line ℓ is $y = \frac{17}{6}x$, or $17x - 6y = 0$.



Solution 2

Since $TD = 10$ and $CD = 15$, we have $CT = CD - TD = 15 - 10 = 5$.

Since $\triangle ATD$ is a right-angled triangle, using the Pythagorean Theorem we have

$$\begin{aligned}AT^2 &= AD^2 + TD^2 \\(r - 0)^2 + (s - 0)^2 &= 15^2 + 10^2 \\r^2 + s^2 &= 325\end{aligned}$$

Since T has coordinates (r, s) , C has coordinates $(3, 21)$, and $CT = 5$, using the distance formula we have

$$\begin{aligned}5 &= \sqrt{(r - 3)^2 + (s - 21)^2} \\25 &= r^2 - 6r + 9 + s^2 - 42s + 441 \\6r + 42s &= r^2 + s^2 + 425\end{aligned}$$

Since $r^2 + s^2 = 325$, we have

$$\begin{aligned}6r + 42s &= 325 + 425 \\&= 750\end{aligned}$$

Again, since T has coordinates (r, s) , D has coordinates $(12, 9)$, and $TD = 10$, using the distance formula we have

$$\begin{aligned}10 &= \sqrt{(r - 12)^2 + (s - 9)^2} \\100 &= r^2 - 24r + 144 + s^2 - 18s + 81 \\24r + 18s &= r^2 + s^2 + 125\end{aligned}$$

Since $r^2 + s^2 = 325$, we have

$$\begin{aligned}24r + 18s &= 325 + 125 \\&= 450\end{aligned}$$

We now have the system of equations

$$\begin{aligned}6r + 42s &= 750 \\24r + 18s &= 450\end{aligned}$$

Multiplying the first equation by 4, we get the system

$$\begin{aligned}24r + 168s &= 3000 \\24r + 18s &= 450\end{aligned}$$

Subtracting the second equation from the first gives $150s = 2550$, and $s = 17$ follows. Substituting $s = 17$ into $6r + 42s = 750$, we obtain $6r + 42(17) = 750$, and $r = 6$ follows.

Thus, the line ℓ passes through $A(0, 0)$ and $T(6, 17)$, has y -intercept 0, and slope $\frac{17 - 0}{6 - 0} = \frac{17}{6}$.

Therefore, the equation of line ℓ is $y = \frac{17}{6}x$, or $17x - 6y = 0$.

EXTENSION:

Can you determine the coordinates of point U on CB such that the area of $\triangle ABU$ is equal to the area of $\triangle ATD$? By finding U and T , you will have found two line segments, AU and AT , that divide square $ABCD$ into three regions of equal area.



Problem of the Week

Problem E

Sum Product Function

A function, g , has $g(2) = 5$ and $g(3) = 7$. In addition, g has the property that

$$g(a) + g(b) = g(ab)$$

for all positive integers a and b .

For example, $g(6) = g(2) + g(3) = 12$.

What is the value of $g(648)$?

$$g(a) + g(b) = g(ab)$$





Problem of the Week

$$g(a) + g(b) = g(ab) \quad \text{Problem E and Solution}$$

Sum Product Function

Problem

A function, g , has $g(2) = 5$ and $g(3) = 7$. In addition, g has the property that

$$g(a) + g(b) = g(ab)$$

for all positive integers a and b .

For example, $g(6) = g(2) + g(3) = 12$.

What is the value of $g(648)$?

Solution

We can rewrite $g(648)$ as:

$$\begin{aligned} g(648) &= g(2 \cdot 324) \\ &= g(2) + g(324) \\ &= g(2) + g(2 \cdot 162) \\ &= g(2) + g(2) + g(162) \\ &= g(2) + g(2) + g(2 \cdot 81) \\ &= g(2) + g(2) + g(2) + g(81) \\ &= g(2) + g(2) + g(2) + g(3 \cdot 27) \\ &= g(2) + g(2) + g(2) + g(3) + g(27) \\ &= g(2) + g(2) + g(2) + g(3) + g(3 \cdot 9) \\ &= g(2) + g(2) + g(2) + g(3) + g(3) + g(9) \\ &= g(2) + g(2) + g(2) + g(3) + g(3) + g(3 \cdot 3) \\ &= g(2) + g(2) + g(2) + g(3) + g(3) + g(3) + g(3) \end{aligned}$$

Therefore, $g(648) = 3g(2) + 4g(3) = 3(5) + 4(7) = 43$.

NOTE:

While this answers the question, is there actually a function that satisfies the requirements?

The answer is yes.

One function that satisfies the requirements of the problem is the function g defined by

$$g(1) = 0 \text{ and } g(2^p 3^q r) = 5p + 7q$$

for all non-negative integers p and q and all positive integers r that are not divisible by 2 or by 3. Can you see why this function satisfies the requirements?

Data Management (D)





Problem of the Week

Problem E

Dis-Card

Noah and Acacia each have nine cards, numbered from 1 to 9. Each person randomly discards one of their cards and then calculates the sum of the numbers on their remaining eight cards.

Calculate the probability that the difference between these two sums is a multiple of 4.





Problem of the Week

Problem E and Solution

Dis-Card

Problem

Noah and Acacia each have nine cards, numbered from 1 to 9. Each person randomly discards one of their cards and then calculates the sum of the numbers on their remaining eight cards.

Calculate the probability that the difference between these two sums is a multiple of 4.

Solution

Let n represent the sum of the numbers on Noah's remaining eight cards, and a represent the sum of the numbers on Acacia's remaining eight cards. In order to determine the probability, we must determine the number of ways n and a can differ by a multiple of 4 and divide by the total number of ways Noah and Acacia can each discard one card.

First, we determine the total number of ways Noah and Acacia can each discard one card. Since each person has 9 cards to choose from, it follows that there are $9 \times 9 = 81$ possibilities.

The sum of the numbers on each person's original cards is $1 + 2 + 3 + 4 + 5 + 6 + 7 + 8 + 9 = \frac{9(10)}{2} = 45$. Since the cards are numbered from 1 to 9, after one card is discarded the remaining sum will be between 36 and 44. From here we present two different solutions.

Solution 1

If Noah discarded the card numbered 1, the sum of the numbers on the remaining cards would be $45 - 1 = 44$, which is n . If Acacia also discarded the card numbered 1, then $a = 44$ as well. Then $n - a = 0$, which is a multiple of 4. Acacia could also discard the cards numbered 5 or 9. Then $a = 45 - 5 = 40$ or $a = 45 - 9 = 36$, and $n - a = 4$ or $n - a = 8$, both of which are multiples of 4.

In general, if Acacia discards a card with the same number as Noah or the same number as Noah increased or decreased by some multiple of 4, then $n - a$ will be a multiple of 4. The following table summarizes the possibilities.

Number Discarded by Noah	Sum of Numbers on Noah's Remaining Cards (n)	Number Discarded by Acacia	Sum of Numbers on Acacia's Remaining Cards (a)	Value of $n - a$	Number of Values of $n - a$ that are Divisible by 4
1	44	1 or 5 or 9	44 or 40 or 36	0 or 4 or 8	3
2	43	2 or 6	43 or 39	0 or 4	2
3	42	3 or 7	42 or 38	0 or 4	2
4	41	4 or 8	41 or 37	0 or 4	2
5	40	1 or 5 or 9	44 or 40 or 36	-4 or 0 or 4	3
6	39	2 or 6	43 or 39	-4 or 0	2
7	38	3 or 7	42 or 38	-4 or 0	2
8	37	4 or 8	41 or 37	-4 or 0	2
9	36	1 or 5 or 9	44 or 40 or 36	-8 or -4 or 0	3

We find that there are $3 + 2 + 2 + 2 + 3 + 2 + 2 + 2 + 3 = 21$ different ways to discard the cards so that n and a differ by a multiple of 4.

Therefore, the probability that n and a differ by a multiple of 4 is $\frac{21}{81} = \frac{7}{27}$.



Solution 2

Let's systematically look at Noah's possible choices.

- Noah removes card 1. Then the sum of the numbers on Noah's remaining cards is $n = 45 - 1 = 44$. The sum of the numbers on Acacia's remaining cards, a , must satisfy $36 \leq a \leq 44$ and $44 - a$ is a multiple of 4. There are three possibilities for a : 44, 40, 36. These values of a correspond to Acacia removing cards 1, 5, and 9, respectively.
- Noah removes card 2. Then the sum of the numbers on Noah's remaining cards is $n = 45 - 2 = 43$. The sum of the numbers on Acacia's remaining cards, a , must satisfy $36 \leq a \leq 44$ and $43 - a$ is a multiple of 4. There are two possibilities for a : 43, 39. These values of a correspond to Acacia removing cards 2 and 6, respectively.
- Noah removes card 3. Then the sum of the numbers on Noah's remaining cards is $n = 45 - 3 = 42$. The sum of the numbers on Acacia's remaining cards, a , must satisfy $36 \leq a \leq 44$ and $42 - a$ is a multiple of 4. There are two possibilities for a : 42, 38. These values of a correspond to Acacia removing cards 3 and 7, respectively.
- Noah removes card 4. Then the sum of the numbers on Noah's remaining cards is $n = 45 - 4 = 41$. The sum of the numbers on Acacia's remaining cards, a , must satisfy $36 \leq a \leq 44$ and $41 - a$ is a multiple of 4. There are two possibilities for a : 41, 37. These values of a correspond to Acacia removing cards 4 and 8, respectively.
- Noah removes card 5. Then the sum of the numbers on Noah's remaining cards is $n = 45 - 5 = 40$. The sum of the numbers on Acacia's remaining cards, a , must satisfy $36 \leq a \leq 44$ and $40 - a$ is a multiple of 4. There are three possibilities for a : 44, 40, 36. These values of a correspond to Acacia removing cards 1, 5, and 9, respectively.
- Noah removes card 6. Then the sum of the numbers on Noah's remaining cards is $n = 45 - 6 = 39$. The sum of the numbers on Acacia's remaining cards, a , must satisfy $36 \leq a \leq 44$ and $39 - a$ is a multiple of 4. There are two possibilities for a : 43, 39. These values of a correspond to Acacia removing cards 2 and 6, respectively.
- Noah removes card 7. Then the sum of the numbers on Noah's remaining cards is $n = 45 - 7 = 38$. The sum of the numbers on Acacia's remaining cards, a , must satisfy $36 \leq a \leq 44$ and $38 - a$ is a multiple of 4. There are two possibilities for a : 42, 38. These values of a correspond to Acacia removing cards 3 and 7, respectively.
- Noah removes card 8. Then the sum of the numbers on Noah's remaining cards is $n = 45 - 8 = 37$. The sum of the numbers on Acacia's remaining cards, a , must satisfy $36 \leq a \leq 44$ and $37 - a$ is a multiple of 4. There are two possibilities for a : 41, 37. These values of a correspond to Acacia removing cards 4 and 8, respectively.
- Noah removes card 9. Then the sum of the numbers on Noah's remaining cards is $n = 45 - 9 = 36$. The sum of the numbers on Acacia's remaining cards, a , must satisfy $36 \leq a \leq 44$ and $36 - a$ is a multiple of 4. There are three possibilities for a : 44, 40, 36. These values of a correspond to Acacia removing cards 1, 5, and 9, respectively.

We find that there are $3 + 2 + 2 + 2 + 3 + 2 + 2 + 2 + 3 = 21$ different ways to discard the cards so that n and a differ by a multiple of 4.

Therefore, the probability that n and a differ by a multiple of 4 is $\frac{21}{81} = \frac{7}{27}$.



Problem of the Week

Problem E

Painting is Fund (Raising)

The POTW High School Painting Club has 30 student members, some from Grade 11 and the remainder from Grade 12. Over the year, they want to fundraise money for the school art department. Each possible pairing of students from the club will create exactly one painting together. When two Grade 11 students paint together, they will sell the painting for \$20. When a Grade 11 and a Grade 12 student paint together, they will sell the painting for \$30. When two Grade 12 students paint together, they will sell the painting for \$40.

When all the paintings are sold, the students will have raised \$13 920. How many of the 30 members of the club are Grade 11 students?





Problem of the Week

Problem E and Solution

Painting is Fund (Raising)

Problem

The POTW High School Painting Club has 30 student members, some from Grade 11 and the remainder from Grade 12. Over the year, they want to fundraise money for the school art department. Each possible pairing of students from the club will create exactly one painting together. When two Grade 11 students paint together, they will sell the painting for \$20. When a Grade 11 and a Grade 12 student paint together, they will sell the painting for \$30. When two Grade 12 students paint together, they will sell the painting for \$40.

When all the paintings are sold, the students will have raised \$13 920. How many of the 30 members of the club are Grade 11 students?

Solution

If 3 students, Student A , Student B , and Student C , are in the same grade, then there will be $(3 \times 2) \div 2 = 3$ pairings, namely AB , AC , and BC . (If we look at this using a counting argument, there would be 3 choices for the first student and for each of these choices, there would be 2 choices for the second student, a total of $3 \times 2 = 6$ pairings, namely AB , AC , BA , BC , CA , and CB . However, notice that each pairing appears twice. Since order is not important we must divide by 2, getting us 3 possible pairings.)

If 3 students, Student A , Student B , and Student C , are in Grade 11 and 2 students, Student D and Student E , are in Grade 12, then there will be $3 \times 2 = 6$ pairings of students in different grades, namely AD , AE , BD , BE , CD , and CE . (There are 3 choices for the Grade 11 student in the pairing and for each of these choices, there are 2 possibilities for the Grade 12 student. This gives a total of $3 \times 2 = 6$ pairings.)

Similar arguments will now be applied to our problem.

Let a represent the number of Grade 11 students in the club and $(30 - a)$ represent the number of Grade 12 students in the club.

Since there are a students in Grade 11 and each must paint with every other student in Grade 11, there will be $a \times (a - 1) \div 2$ paintings from pairs where both students are in Grade 11. Thus, the amount raised by paintings from pairs where both students are in Grade 11 would be

$$20 \times \left(\frac{a(a - 1)}{2} \right)$$



Similarly, since there are $(30 - a)$ students in Grade 12 and each must paint with every other student in Grade 12, there will be

$(30 - a) \times (30 - a - 1) \div 2 = (30 - a) \times (29 - a) \div 2$ paintings from pairs where both students are in Grade 12. Thus, the amount raised by paintings from pairs where both students are in Grade 12 would be

$$40 \times \left(\frac{(30 - a)(29 - a)}{2} \right)$$

Since every Grade 11 student must paint with every Grade 12 student, there will be $a \times (30 - a)$ paintings from pairs with one student from each grade. Thus, the amount raised by paintings from pairs with one student from each grade would be

$$30 \times (a(30 - a))$$

Therefore,

$$13\,920 = 20 \left(\frac{a(a - 1)}{2} \right) + 40 \left(\frac{(30 - a)(29 - a)}{2} \right) + 30(a(30 - a))$$

$$13\,920 = 10(a^2 - a) + 20(870 - 59a + a^2) + 30(30a - a^2)$$

$$1392 = (a^2 - a) + 2(870 - 59a + a^2) + 3(30a - a^2)$$

$$1392 = a^2 - a + 1740 - 118a + 2a^2 + 90a - 3a^2$$

$$1392 = -29a + 1740$$

$$29a = 348$$

$$a = 12$$

Therefore, 12 of the students in the club are in Grade 11.



Problem of the Week

Problem E

Dot Remover

Manfred has six cards. One card has 2 dots on it, one card has 3 dots on it, one card has 4 dots on it, one card has 5 dots on it, one card has 6 dots on it, and one card has 7 dots on it.

Manfred removes one of the dots at random, with each of the 27 dots equally likely to be removed. Esther then randomly chooses one of the cards, with each card equally likely to be chosen.

What is the probability that the card chosen by Esther has an odd number of dots on it?

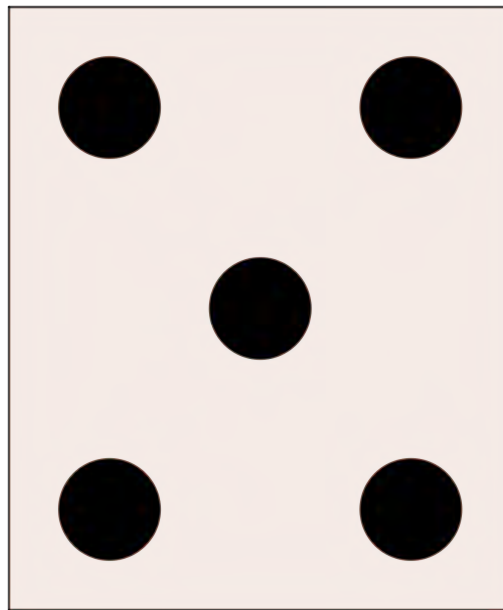

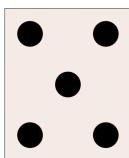

Problem of the Week

Problem E and Solution

Dot Remover

Problem

Manfred has six cards. One card has 2 dots on it, one card has 3 dots on it, one card has 4 dots on it, one card has 5 dots on it, one card has 6 dots on it, and one card has 7 dots on it.

Manfred removes one of the dots at random, with each of the 27 dots equally likely to be removed. Esther then randomly chooses one of the cards, with each card equally likely to be chosen.

What is the probability that the card chosen by Esther has an odd number of dots on it?

Solution

Initially, there are three cards with an even number of dots and three cards with an odd number of dots. When a dot is removed from a card with an even number of dots, that card then has an odd number of dots. When a dot is removed from a card with an odd number of dots, that card then has an even number of dots.

If a dot is removed from a card with an even number of dots, then there will be four cards with an odd number of dots and two cards with an even number of dots. This means that the probability of choosing a card with an odd number of dots after a dot is removed is $\frac{4}{6} = \frac{2}{3}$ in this case.

If a dot is removed from a card with an odd number of dots, then there will be two cards with an odd number of dots and four cards with an even number of dots. This means that the probability of choosing a card with an odd number of dots after a dot is removed is $\frac{2}{6} = \frac{1}{3}$ in this case.

Since there are $2 + 3 + 4 + 5 + 6 + 7 = 27$ dots in total, then the probability that a dot is removed from the card with 2 dots is $\frac{2}{27}$, from the card with 3 dots is $\frac{3}{27}$, and so on. Thus, the probability that a dot is removed from the card with 2 dots and then a card with an odd number of dots is chosen is $\frac{2}{27} \times \frac{2}{3}$, since there are now four cards with an odd number of dots and two cards with an even number of dots.

Similarly, the probability that a dot is removed from the card with 3 dots and then a card with odd number of dots is chosen is $\frac{3}{27} \times \frac{1}{3}$.

Continuing in this way, the probability of choosing a card with an odd number of dots after a dot is removed is $\frac{2}{27} \times \frac{2}{3} + \frac{3}{27} \times \frac{1}{3} + \frac{4}{27} \times \frac{2}{3} + \frac{5}{27} \times \frac{1}{3} + \frac{6}{27} \times \frac{2}{3} + \frac{7}{27} \times \frac{1}{3}$.

This is equal to

$$\frac{2}{3} \left(\frac{2}{27} + \frac{4}{27} + \frac{6}{27} \right) + \frac{1}{3} \left(\frac{3}{27} + \frac{5}{27} + \frac{7}{27} \right) = \frac{2}{3} \left(\frac{12}{27} \right) + \frac{1}{3} \left(\frac{15}{27} \right) = \frac{8}{27} + \frac{5}{27} = \frac{13}{27}.$$



Problem of the Week

Problem E

Twelve Cousins

Arya has twelve cousins. She secretly writes their ages, as positive integers, on a piece of paper. She then tells you the mean (average) of the twelve ages is 8.75 and the median is 10. Finally, she draws you the following histogram to represent the ages of her cousins.

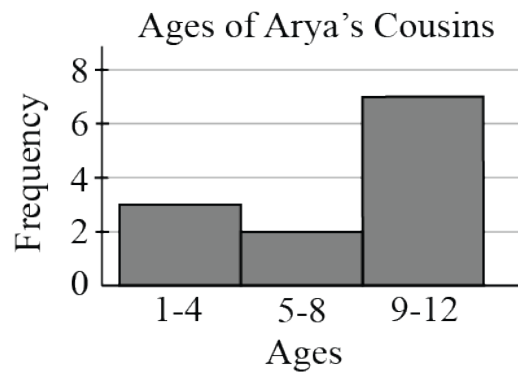

How many possibilities are there for the ages of Arya's twelve cousins?



Problem of the Week

Problem E and Solution

Twelve Cousins

Problem

Arya has twelve cousins. She secretly writes their ages, as positive integers, on a piece of paper. She then tells you the mean (average) of the twelve ages is 8.75 and the median is 10. Finally, she draws you the following histogram to represent the ages of her cousins.

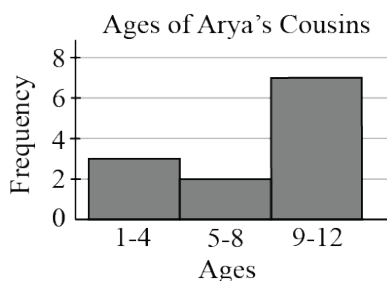

How many possibilities are there for the ages of Arya's twelve cousins?

Solution

Since there are 12 ages, the median will be the number halfway between the sixth and seventh ages when they are arranged in increasing order. From the histogram, we know that the sixth and seventh ages are both between 9 and 12. Since the median is 10, it follows that the sixth and seventh ages are either 9 and 11, respectively, or they are both 10.

Since the mean of the 12 ages is 8.75, it follows that the sum of all 12 ages is $8.75 \times 12 = 105$. We know from the previous paragraph that the sixth and seventh ages are either 9 and 11, respectively, or they are both 10. Either way, their sum is 20. So the sum of the remaining ten ages is $105 - 20 = 85$. From the histogram, we know that three of these ages are between 1 and 4, two of these ages are between 5 and 8, and the remaining five are between 9 and 12 and also greater than the seventh age, which is either 10 or 11.

We will consider cases by looking at the possible sums of the five smallest ages.

Case 1: The sum of the five smallest ages is 28.

This is the maximum possible sum of the five smallest ages, and occurs when the ages are 4, 4, 4, 8, 8. The corresponding sum of the five largest ages is then $85 - 28 = 57$.

- If the seventh age is 10, then the five largest ages could be 10, 11, 12, 12, 12 or 11, 11, 11, 12, 12. Thus, there are 2 possibilities for the ages of Arya's cousins.
- If the seventh age is 11, then the five largest ages could only be 11, 11, 11, 12, 12. Thus, there is 1 possibility for the ages of Arya's cousins.

In total, there are $2 + 1 = 3$ possibilities for the ages of Arya's cousins if the sum of the five smallest ages is 28.



Case 2: The sum of the five smallest ages is 27.

This occurs when the ages are 3, 4, 4, 8, 8 or 4, 4, 4, 7, 8. The corresponding sum of the five largest ages is then $85 - 27 = 58$.

- If the seventh age is 10, then the five largest ages could be 10, 12, 12, 12, 12 or 11, 11, 12, 12, 12. Thus, there are 2 possibilities for the five smallest ages and 2 possibilities for the five largest ages, which results in $2 \times 2 = 4$ possibilities for the ages of Arya's cousins.
- If the seventh age is 11, then the five largest ages could only be 11, 11, 12, 12, 12. Thus, there are 2 possibilities for the five smallest ages and 1 possibility for the five largest ages, which results in $2 \times 1 = 2$ possibilities for the ages of Arya's cousins.

In total, there are $4 + 2 = 6$ possibilities for the ages of Arya's cousins if the sum of the five smallest ages is 27.

Case 3: The sum of the five smallest ages is 26.

This occurs when the ages are 2, 4, 4, 8, 8 or 3, 3, 4, 8, 8 or 3, 4, 4, 7, 8 or 4, 4, 4, 6, 8 or 4, 4, 4, 7, 7. The corresponding sum of the five largest ages is then $85 - 26 = 59$. The only possibility for the five largest ages is 11, 12, 12, 12, 12. Thus, there are 5 possibilities for the five smallest ages, 2 possibilities for the two middle ages, and 1 possibility for the five largest ages, which results in $5 \times 2 \times 1 = 10$ possibilities for the ages of Arya's cousins if the sum of the five smallest ages is 26.

Case 4: The sum of the five smallest ages is 25.

This occurs when the ages are 1, 4, 4, 8, 8 or 2, 3, 4, 8, 8 or 2, 4, 4, 7, 8 or 3, 3, 3, 8, 8 or 3, 3, 4, 7, 8 or 3, 4, 4, 6, 8 or 3, 4, 4, 7, 7 or 4, 4, 4, 5, 8 or 4, 4, 4, 6, 7. The corresponding sum of the five largest ages is then $85 - 25 = 60$. This is the maximum possible sum of the five largest ages and occurs when the ages are 12, 12, 12, 12, 12. Thus, there are 9 possibilities for the five smallest ages, 2 possibilities for the two middle ages, and 1 possibility for the five largest ages, which results in $9 \times 2 \times 1 = 18$ possibilities for the ages of Arya's cousins if the sum of the five smallest ages is 25.

Therefore, in total, there are $3 + 6 + 10 + 18 = 37$ possibilities for the ages of Arya's twelve cousins.

Computational Thinking (C)





Problem of the Week

Problem E

A Scurry of Chipmunks

In Kumi's backyard there are five logs lined up in a row next to her vegetable garden. Unbeknownst to her, under each log there is a burrow where some chipmunks live. The chipmunks do not always stay in the same burrow but they always stay in Kumi's backyard because they enjoy eating the food from her garden.

Every day each chipmunk counts the number of *other* chipmunks in their current burrow, as well as the number of chipmunks in the adjacent burrow(s). Every night, each chipmunk either stays in its current burrow, or moves to an adjacent burrow according to the following rules.

1. If the number of chipmunks in an adjacent burrow is less than the number of *other* chipmunks in their current burrow, then move to the adjacent burrow with the fewest number of chipmunks. In the case of a tie, move to the adjacent burrow that is closer to the garden.
2. Otherwise, if they are not already in the burrow closest to the garden, and the number of chipmunks in the adjacent burrow closer to the garden is equal to the number of *other* chipmunks in their current burrow, then move to the adjacent burrow closer to the garden.
3. Otherwise, stay in their current burrow.

The chipmunks follow these rules every day until all the chipmunks are in the same burrow; however this sometimes never happens!

For each of the following scenarios, determine whether or not all the chipmunks will end up in the same burrow, and if so, how many days it will take for this to happen. The number on each log represents the total number of chipmunks in the corresponding burrow on the initial day.

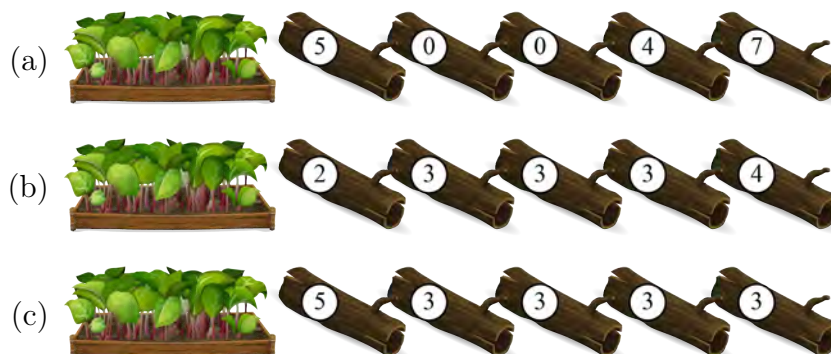

An example scenario and solution are given on the following page.



Consider the following example scenario.



We will look at what happens each night for the chipmunks in each burrow. We number the burrows from 1 to 5, starting with the burrow closest to the garden.

- Initial Day to Day 1:

- Each chipmunk in Burrow 1 currently has 5 others with them. Since there are fewer chipmunks in Burrow 2, all chipmunks in Burrow 1 will move to Burrow 2.
- Each chipmunk in Burrow 2 currently has 2 others with them. Since there are more chipmunks in Burrow 1, and the same amount in Burrow 3, all chipmunks in Burrow 2 will stay in Burrow 2.
- Each chipmunk in Burrow 3 currently has 1 other with them. Since there are fewer chipmunks in Burrow 4, all chipmunks in Burrow 3 will move to Burrow 4.
- Each chipmunk in Burrow 5 currently has 3 others with them. Since there are fewer chipmunks in Burrow 4, all chipmunks in Burrow 5 will move to Burrow 4.

The chipmunks will then be arranged as follows:

GARDEN

 0 9 0 6 0

- Day 1 to Day 2:

- Each chipmunk in Burrow 2 currently has 8 others with them. Since there are 0 chipmunks in Burrows 1 and 3, all chipmunks in Burrow 2 will move to Burrow 1, because it is closer to the garden.
- Each chipmunk in Burrow 4 currently has 5 others with them. Since there are 0 chipmunks in Burrows 3 and 5, all chipmunks in Burrow 4 will move to Burrow 3, because it is closer to the garden.

The chipmunks will then be arranged as follows:

GARDEN

 9 0 6 0 0

- Day 2 to Day 3:

- Each chipmunk in Burrow 1 currently has 8 others with them. Since there are fewer chipmunks in Burrow 2, all chipmunks in Burrow 1 will move to Burrow 2.
- Each chipmunk in Burrow 3 currently has 5 others with them. Since there are 0 chipmunks in Burrows 2 and 4, all chipmunks in Burrow 3 will move to Burrow 2, because it is closer to the garden.

The chipmunks will then be arranged as follows:

GARDEN

 0 15 0 0 0

Therefore, after 3 days, all the chipmunks will be in the same burrow.





Problem of the Week

Problem E and Solution

A Scurry of Chipmunks

Problem

In Kumi's backyard there are five logs lined up in a row next to her vegetable garden. Unbeknownst to her, under each log there is a burrow where some chipmunks live. The chipmunks do not always stay in the same burrow but they always stay in Kumi's backyard because they enjoy eating the food from her garden.

Every day each chipmunk counts the number of *other* chipmunks in their current burrow, as well as the number of chipmunks in the adjacent burrow(s). Every night, each chipmunk either stays in its current burrow, or moves to an adjacent burrow according to the following rules.

1. If the number of chipmunks in an adjacent burrow is less than the number of *other* chipmunks in their current burrow, then move to the adjacent burrow with the fewest number of chipmunks. In the case of a tie, move to the adjacent burrow that is closer to the garden.
2. Otherwise, if they are not already in the burrow closest to the garden, and the number of chipmunks in the adjacent burrow closer to the garden is equal to the number of *other* chipmunks in their current burrow, then move to the adjacent burrow closer to the garden.
3. Otherwise, stay in their current burrow.

The chipmunks follow these rules every day until all the chipmunks are in the same burrow; however this sometimes never happens!

For each of the following scenarios, determine whether or not all the chipmunks will end up in the same burrow, and if so, how many days it will take for this to happen. The number on each log represents the total number of chipmunks in the corresponding burrow on the initial day.

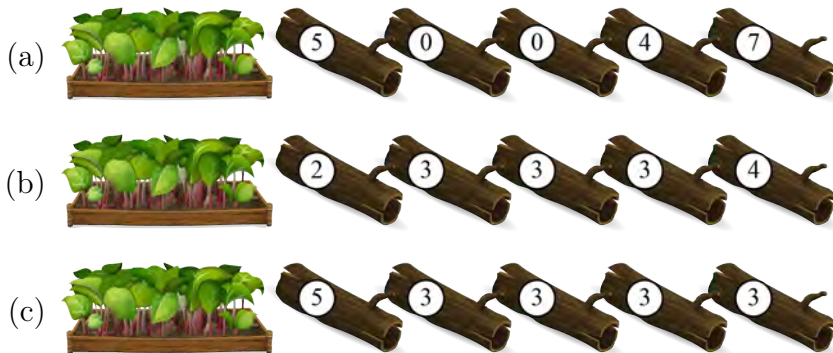



Solution

We number the burrows from 1 to 5, starting with the burrow closest to the garden. To help condense the solution, we have written these as B1, B2, B3, B4, and B5.

(a) We will look at what happens each night for the chipmunks in each burrow.

- Initial Day to Day 1:

- All chipmunks in B1 move to B2, since 0 others is less than 4 others.
- All chipmunks in B4 move to B3, since 0 others is less than 3 others or 7 others.
- All chipmunks in B5 move to B4, since 4 others is less than 6 others.

The chipmunks will then be arranged as follows:

GARDEN

 0 5 4 7 0

- Day 1 to Day 2:

- All chipmunks in B2 move to B1, since 0 others is less than 4 others.
- All chipmunks in B3 stay in B3, since 3 others is less than 5 others or 7 others.
- All chipmunks in B4 move to B5, since 0 others is less than 6 others or 4 others.

The chipmunks will then be arranged as follows:

GARDEN

 5 0 4 0 7

- Day 2 to Day 3:

- All chipmunks in B1 move to B2, since 0 others is less than 4 others.
- All chipmunks in B3 move to B2, since 0 others is less than 3 others, and B2 is closer to the garden than B4.
- All chipmunks in B5 move to B4, since 0 others is less than 6 others.

The chipmunks will then be arranged as follows:

GARDEN

 0 9 0 7 0

- Day 3 to Day 4:

- All chipmunks in B2 move to B1, since 0 others is less than 8 others, and B1 is closer to the garden than B3.
- All chipmunks in B4 move to B3, since 0 others is less than 6 others, and B3 is closer to the garden than B5.

The chipmunks will then be arranged as follows:

GARDEN

 9 0 7 0 0

- Day 4 to Day 5:

- All chipmunks in B1 move to B2, since 0 others is less than 8 others.
- All chipmunks in B3 move to B2, since 0 others is less than 6 others, and B2 is closer to the garden than B4.

The chipmunks will then be arranged as follows:

GARDEN

 0 16 0 0 0

Therefore, after 5 days, all the chipmunks will be in the same burrow.

(b) We will look at what happens each night for the chipmunks in each burrow.

- Initial Day to Day 1:

- All chipmunks in B1 stay in B1, since 1 other is less than 3 others.
- All chipmunks in B2 move to B1, since B1 is closer to the garden.
- All chipmunks in B3 stay in B3, since 2 others is less than 3 others.
- All chipmunks in B4 stay in B4, since 2 others is less than 3 others or 4 others.
- All chipmunks in B5 move to B4, since B4 is closer to the garden.

The chipmunks will then be arranged as follows:

GARDEN

 5 0 3 7 0



- Day 1 to Day 2:
 - All chipmunks in B1 move to B2, since 0 others is less than 4 others.
 - All chipmunks in B3 move to B2, since 0 others is less than 2 others or 7 others.
 - All chipmunks in B4 move to B5, since 0 others is less than 6 others or 3 others.

The chipmunks will then be arranged as follows: GARDEN 0 8 0 0 7

- Day 2 to Day 3:
 - All chipmunks in B2 move to B1, since 0 others is less than 7 others, and B1 is closer to the garden than B3.
 - All chipmunks in B5 move to B4, since 0 others is less than 6 others.

The chipmunks will then be arranged as follows: GARDEN 8 0 0 7 0

- Day 3 to Day 4:
 - All chipmunks in B1 move to B2, since 0 others is less than 7 others.
 - All chipmunks in B4 move to B3, since 0 others is less than 6 others, and B3 is closer to the garden than B5.

The chipmunks will then be arranged as follows: GARDEN 0 8 7 0 0

- Day 4 to Day 5:
 - All chipmunks in B2 move to B1, since 0 others is less than 7 others.
 - All chipmunks in B3 move to B4, since 0 others is less than 6 others or 8 others.

The chipmunks will then be arranged as follows: GARDEN 8 0 0 7 0

This is the same as the start of Day 3, so Day 6 will start the same as Day 4, and the cycle will repeat. Therefore, all the chipmunks will never end up in the same burrow.

(c) We will look at what happens each night for the chipmunks in each burrow.

- Initial Day to Day 1:
 - All chipmunks in B1 move to B2, since 3 others is less than 4 others.
 - All chipmunks in B2 stay in B2, since 2 others is less than 3 others or 5 others.
 - All chipmunks in B3, B4, and B5 stay in their current burrows, since 2 others is less than 3 others.

The chipmunks will then be arranged as follows: GARDEN 0 8 3 3 3

- Day 1 to Day 2:
 - All chipmunks in B2 move to B1, since 0 others is less than 7 others or 3 others.
 - All chipmunks in B3 stay in B3, since 2 others is less than 8 others or 3 others.
 - All chipmunks in B4 and B5 stay in their current burrows, since 2 others is less than 3 others.

The chipmunks will then be arranged as follows: GARDEN 8 0 3 3 3

- Day 2 to Day 3:
 - All chipmunks in B1 move to B2, since 0 others is less than 7 others.
 - All chipmunks in B3 move to B2, since 0 others is less than 2 others or 3 others.
 - All chipmunks in B4 and B5 stay in their current burrows, since 2 others is less than 3 others.

The chipmunks will then be arranged as follows: GARDEN 0 11 0 3 3



- Day 3 to Day 4:
 - All chipmunks in B2 move to B1, since 0 others is less than 10 others, and B1 is closer to the garden than B3.
 - All chipmunks in B4 move to B3, since 0 others is less than 2 others or 3 others.
 - All chipmunks in B5 stay in B5, since 2 others is less than 3 others.

The chipmunks will then be arranged as follows:

GARDEN

 11 0 3 0 3

- Day 4 to Day 5:
 - All chipmunks in B1 move to B2, since 0 others is less than 10 others.
 - All chipmunks in B3 move to B2, since 0 others is less than 2 others, and B2 is closer to the garden than B4.
 - All chipmunks in B5 move to B4, since 0 others is less than 2 others.

The chipmunks will then be arranged as follows:

GARDEN

 0 14 0 3 0

- Day 5 to Day 6:
 - All chipmunks in B2 move to B1, since 0 others is less than 13 others, and B1 is closer to the garden than B3.
 - All chipmunks in B4 move to B3, since 0 others is less than 2 others, and B3 is closer to the garden than B5.

The chipmunks will then be arranged as follows:

GARDEN

 14 0 3 0 0

- Day 6 to Day 7:
 - All chipmunks in B1 move to B2, since 0 others is less than 13 others.
 - All chipmunks in B3 move to B2, since 0 others is less than 2 others, and B2 is closer to the garden than B4.

The chipmunks will then be arranged as follows:

GARDEN

 0 17 0 0 0

Therefore, after 7 days, all the chipmunks will be in the same burrow.

EXTENSION:

In parts (a) and (c), the chipmunks all came together in Burrow 2. If the chipmunks do come together in the same burrow, will it always happen in Burrow 2?



Problem of the Week

Problem E

Adventure Travel

A tour company is planning adventure day trips to a small island. Every morning, a boat will take a group of people to the dock on the west side of the island. Each person will then choose a route to travel through the island, doing different activities along the way. The final activities will finish at the dock on the east side of the island, where a boat will take everyone back to the mainland in the evening.

The map below shows all the possible routes people can travel through the island starting from the dock on the west side (A) and finishing at the dock on the east side (J). The activity for each section is shown, as well as the maximum number of people that can do each activity per day due to equipment and/or time constraints.

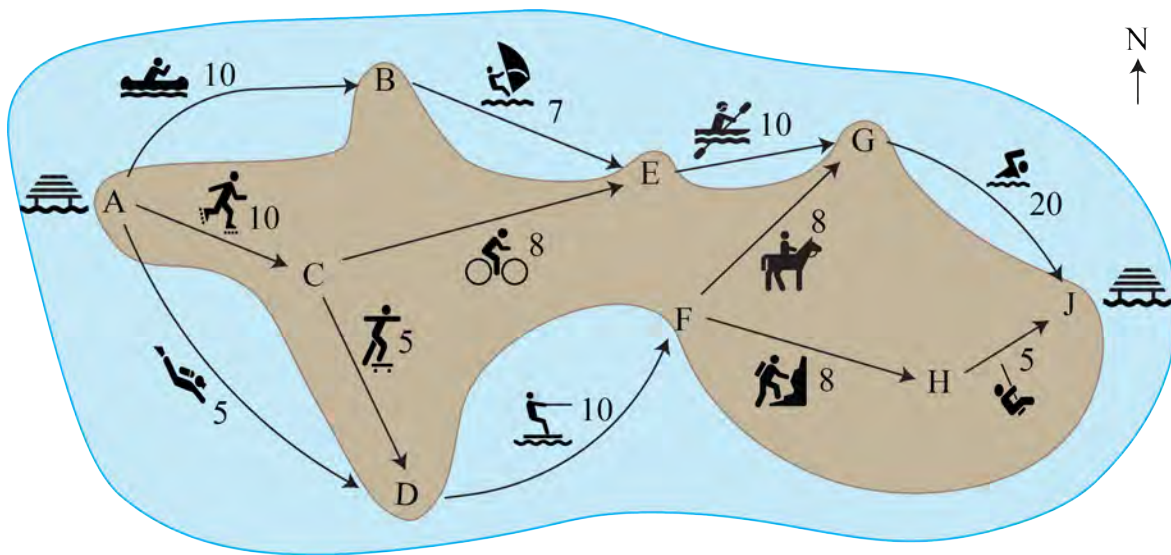

What is the maximum number of people that can travel from A to J in one day using only the routes and activities shown?

This problem was inspired by a past [Beaver Computing Challenge \(BCC\)](#) problem.





Problem of the Week

Problem E and Solution

Adventure Travel

Problem

A tour company is planning adventure day trips to a small island. Every morning, a boat will take a group of people to the dock on the west side of the island. Each person will then choose a route to travel through the island, doing different activities along the way. The final activities will finish at the dock on the east side of the island, where a boat will take everyone back to the mainland in the evening.

The map below shows all the possible routes people can travel through the island starting from the dock on the west side (A) and finishing at the dock on the east side (J). The activity for each section is shown, as well as the maximum number of people that can do each activity per day due to equipment and/or time constraints.

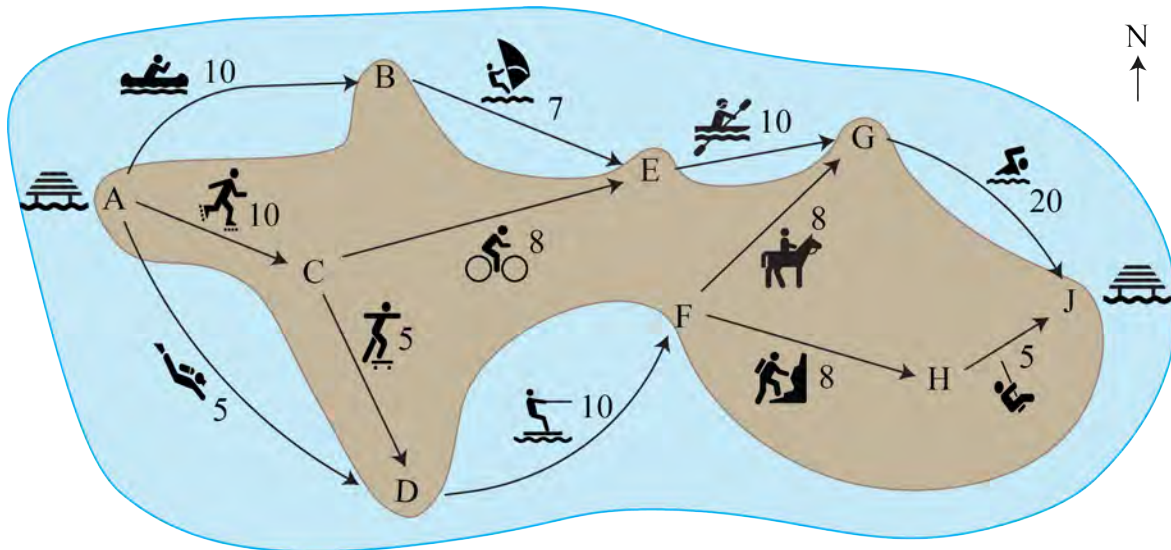

What is the maximum number of people that can travel from A to J in one day using only the routes and activities shown?

This problem was inspired by a past [Beaver Computing Challenge \(BCC\)](#) problem.

Solution

The maximum number of people that can travel from A to J in one day using only the routes and activities shown is 20. First we will show a possible way that 20 people can travel from A to J , and then we will prove that this is the maximum.

After the 20 people arrive at A , 5 of them should go to B , 10 of them should go to C , and 5 of them should go to D . The people will then be distributed as follows.



Location	<i>A</i>	<i>B</i>	<i>C</i>	<i>D</i>	<i>E</i>	<i>F</i>	<i>G</i>	<i>H</i>	<i>J</i>
Number of People	0	5	10	5	0	0	0	0	0

From *B*, the only possible route goes to *E*, so everyone from *B* should go to *E*. From *C*, 5 of the people should go to *E* and the remaining 5 people should go to *D*. The people will then be distributed as follows.

Location	<i>A</i>	<i>B</i>	<i>C</i>	<i>D</i>	<i>E</i>	<i>F</i>	<i>G</i>	<i>H</i>	<i>J</i>
Number of People	0	0	0	10	10	0	0	0	0

From *D*, the only possible route goes to *F*. Similarly from *E*, the only possible route goes to *G*. So all of the people at *D* should go to *F* and all of the people at *E* should go to *G*. The people will then be distributed as follows.

Location	<i>A</i>	<i>B</i>	<i>C</i>	<i>D</i>	<i>E</i>	<i>F</i>	<i>G</i>	<i>H</i>	<i>J</i>
Number of People	0	0	0	0	0	10	10	0	0

From *F*, 5 of the people should go to *G* and the remaining 5 people should go to *H*. The people will then be distributed as follows.

Location	<i>A</i>	<i>B</i>	<i>C</i>	<i>D</i>	<i>E</i>	<i>F</i>	<i>G</i>	<i>H</i>	<i>J</i>
Number of People	0	0	0	0	0	0	15	5	0

Everyone from *G* and *H* should then go to *J*. Using these routes, a total of 20 people can travel from *A* to *J*. Note that this is not the only possible way for 20 people to travel from *A* to *J*.

We now must show that it is not possible for more than 20 people to travel from *A* to *J* in one day. Suppose we separate the island into two groups. The west group contains *A*, *B*, *C*, *D*, and *E*. The east group contains *F*, *G*, *H*, and *J*. In order to travel from *A* to *J*, people must travel from the west group to the east group. However there are only two ways to travel between the west group and the east group. At most 10 people can travel from *E* to *G*, and at most 10 people can travel from *D* to *F* in one day. So, in total, at most $10 + 10 = 20$ people can travel from the west group to the east group in one day. Since we have found a way for 20 people to travel from *A* to *J* in one day, it follows that the maximum number of people that can travel from *A* to *J* in one day is 20.



Problem of the Week

Problem E

Adding Some Colour 3

Lucia and Henrik play a game where they take turns colouring regions in the diagram shown red or blue. On their turn, each player colours a region in the diagram that is not bordering another region of the same colour.

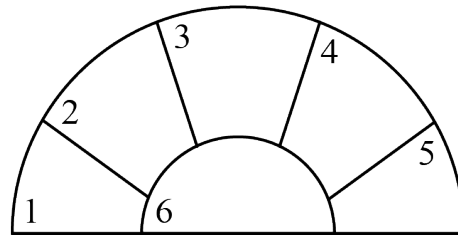

After some number of turns, it won't be possible to colour any more regions, and the game will be over. The winner is the player who coloured the last region.

Lucia went first. On her turn, she coloured region 5 blue, so after her turn the diagram is coloured as follows.

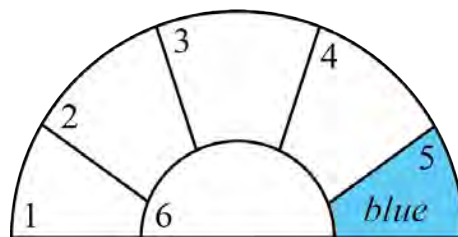

It is now Henrik's turn and there are five remaining regions. Determine all possibilities for the colour Henrik should use and the region he should choose in order to guarantee that he wins the game, regardless of what Lucia does on her remaining turns.





Problem of the Week

Problem E and Solution

Adding Some Colour 3

Problem

Lucia and Henrik play a game where they take turns colouring regions in the diagram shown red or blue. On their turn, each player colours a region in the diagram that is not bordering another region of the same colour.

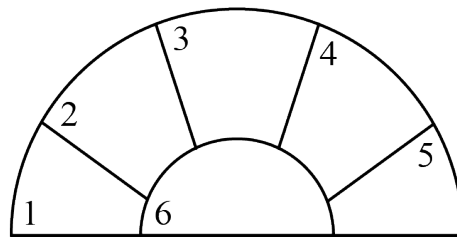

After some number of turns, it won't be possible to colour any more regions, and the game will be over. The winner is the player who coloured the last region.

Lucia went first. On her turn, she coloured region 5 blue, so after her turn the diagram is coloured as follows.

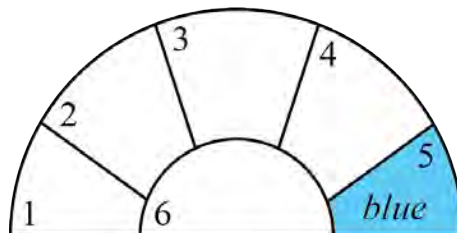

It is now Henrik's turn and there are five remaining regions. Determine all possibilities for the colour Henrik should use and the region he should choose in order to guarantee that he wins the game, regardless of what Lucia does on her remaining turns.

Solution

If Henrik colours region 1 red on his first turn, then he will be guaranteed to win the game, regardless of what Lucia does on her remaining turns. First we will show why this is true, and then we will show why all the other possible moves will not guarantee a win for Henrik.

If Henrik colours region 1 red, then the only possible moves for Lucia are to colour region 2 blue, region 3 red or blue, or region 4 red.

- If Lucia colours region 2 blue, then the only possible moves for Henrik are to colour region 3 or 4 red. After Henrik chooses one of these moves, there will be no possible moves left and Henrik will win the game.



- If Lucia colours region 3 blue, then the only possible move for Henrik is to colour region 4 red. After Henrik does this, there will be no possible moves left and Henrik will win the game.
- If Lucia colours region 3 red, then the only possible move for Henrik is to colour region 2 blue. After Henrik does this, there will be no possible moves left and Henrik will win the game.
- If Lucia colours region 4 red, then the only possible moves for Henrik are to colour region 2 or region 3 blue. After Henrik chooses one of these moves, there will be no possible moves left and Henrik will win the game.

Thus, if Henrik colours region 1 red, then he is guaranteed to win the game, regardless of what Lucia does on her remaining turns.

The other possible moves for Henrik are to colour region 1, region 2, or region 3 blue, or to colour region 2, region 3, region 4, or region 6 red.

- If Henrik coloured region 1 blue, then Lucia could colour region 3 red. There would then be no possible moves left, so Lucia would win the game.
- If Henrik coloured region 2 blue, then Lucia could colour region 6 red. There would then be no possible moves left, so Lucia would win the game.
- If Henrik coloured region 3 blue, then Lucia could colour region 2 red. Then the only possible remaining moves would be to colour region 1 blue or to colour region 4 red. Since these moves don't affect each other, Henrik would colour one of these regions and Lucia would colour the other and win the game.
- If Henrik coloured region 2 red, then Lucia could colour region 3 blue. Then the only possible remaining moves would be to colour region 1 blue or to colour region 4 red. Since these moves don't affect each other, Henrik would colour one of these regions and Lucia would colour the other and win the game.
- If Henrik coloured region 3 red, then Lucia could colour region 1 blue. There would then be no possible moves left, so Lucia would win the game.
- If Henrik coloured region 4 red, then Lucia could colour region 2 red. Then the only possible remaining moves would be to colour region 1 blue or to colour region 3 blue. Since these moves don't affect each other, Henrik would colour one of these regions and Lucia would colour the other and win the game.
- If Henrik coloured region 6 red, then Lucia could colour region 2 blue. There would then be no possible moves left, so Lucia would win the game.

Therefore, colouring region 1 red is the only move Henrik can do in order to guarantee that he wins the game, regardless of what Lucia does on her remaining turns.