

Problème de la Semaine

Problèmes et Solutions 2023-2024

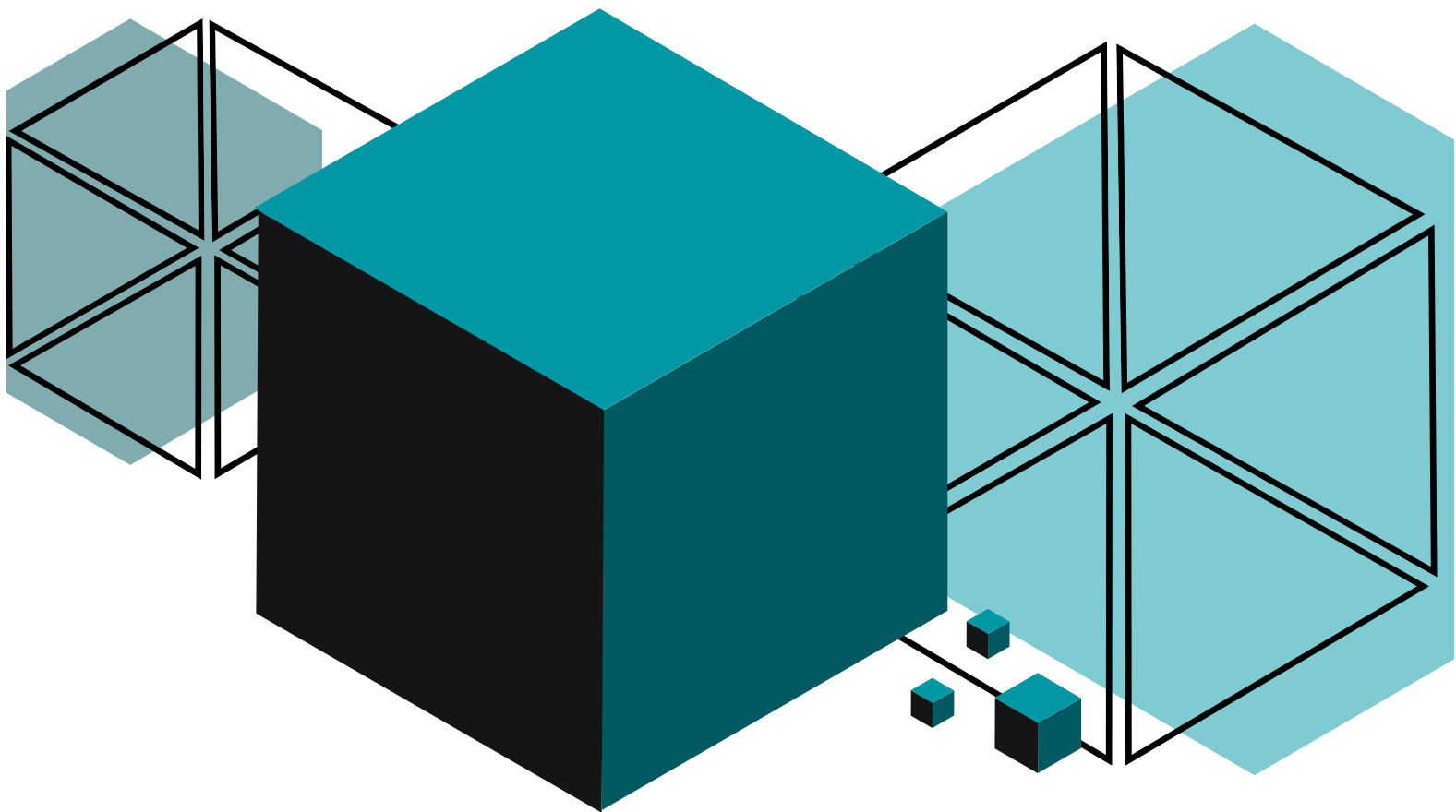

Problème D

9e/10e année



Le CENTRE d'ÉDUCATION
en MATHÉMATIQUES et en INFORMATIQUE
cemc@uwaterloo.ca

Table des Matières

Les problèmes dans ce livret sont organisés par thème.
Un problème peut apparaître dans plusieurs thèmes.
Cliquer sur le nom du thème ci-dessous pour sauter à cette section.

[Algèbre \(A\)](#)

[Raisonnement informatiques \(C\)](#)

[Gestion des données \(D\)](#)

[Géométrie et mesure \(G\)](#)

[Sens du nombre \(N\)](#)

Algèbre (A)

**Amène-moi à la
couverture**



Problème de la semaine

Problème D

Mangues et oranges

Au supermarché de PDLs, Livio s'occupe de la mise en rayon des mangues tandis que Dhruv s'occupe de la mise en rayon des oranges. Un jour, ils ont remarqué qu'un nombre égal de mangues et d'oranges étaient pourries. De plus, $\frac{2}{3}$ des mangues étaient pourries et $\frac{3}{4}$ des oranges étaient pourries. Quelle fraction du nombre total de mangues et d'oranges était pourrie ?

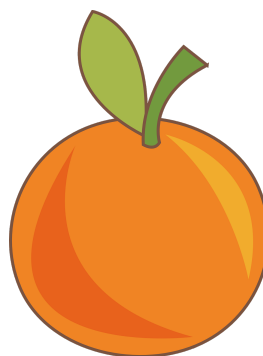
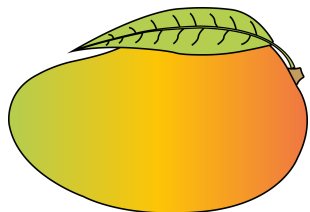

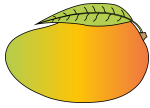

Problem of the Week

Problem D and Solution

Mangoes and Oranges



Problem

At POTW's Supermarket, Livio stocks mangoes and Dhruv stocks oranges. One day they noticed that an equal number of mangoes and oranges were rotten. Also, $\frac{2}{3}$ of the mangoes were rotten and $\frac{3}{4}$ of the oranges were rotten. What fraction of the total number of mangoes and oranges was rotten?

Solution

Solution 1:

Let the total number of mangoes be represented by a and the total number of oranges be represented by b . Since there were an equal number of rotten mangoes and rotten oranges, then $\frac{2}{3}a = \frac{3}{4}b$, so $b = \frac{4}{3}(\frac{2}{3}a) = \frac{8}{9}a$.

Therefore, there were a total of $a + b = a + \frac{8}{9}a = \frac{17}{9}a$ mangoes and oranges.

Also, the total amount of rotten fruit was $2(\frac{2}{3}a) = \frac{4}{3}a$.

Therefore, $\frac{\frac{4}{3}a}{\frac{17}{9}a} = \frac{4}{3}(\frac{9}{17}) = \frac{12}{17}$ of the total number of mangoes and oranges was rotten.

Solution 2:

Since $\frac{2}{3}$ of the mangoes were rotten, $\frac{3}{4}$ of the oranges were rotten, and the number of rotten mangoes equaled the number of rotten oranges, suppose there were 6 rotten mangoes. (We choose 6 as it is a multiple of the numerator of each fraction.) Then the number of rotten oranges will also be 6.

If there were 6 rotten mangoes, then there were a total of $6 \div \frac{2}{3} = 6(\frac{3}{2}) = 9$ mangoes.

If there were 6 rotten oranges, then there were a total of $6 \div \frac{3}{4} = 6(\frac{4}{3}) = 8$ oranges.

Therefore, there were $9 + 8 = 17$ pieces of fruit in total, of which $6 + 6 = 12$ were rotten.

Thus, $\frac{12}{17}$ of the total number of mangoes and oranges was rotten.

NOTE: In Solution 2 we could have used any multiple 6 for the number of rotten mangoes and thus the number of rotten oranges. The final fraction would always reduce to $\frac{12}{17}$. We will show this in general in Solution 3.

Solution 3:

According to the problem, there were an equal number of rotten mangoes and rotten oranges.

Let the number of rotten mangoes and rotten oranges each be $6x$, for some positive integer x .

The total number of mangoes was thus $6x \div \frac{2}{3} = 9x$.

The total number of oranges was thus $6x \div \frac{3}{4} = 8x$.

Therefore, the total number of mangoes and oranges was $9x + 8x = 17x$.

Also, the total number of rotten mangoes and rotten oranges was $6x + 6x = 12x$.

Therefore, $\frac{12x}{17x} = \frac{12}{17}$ of the total number of mangoes and oranges was rotten.



Problème de la semaine

Problème D

Carrément imbriqué

Dans le carré $PQRS$, W est situé sur PQ , U est situé sur QR , T est situé sur PS et V est situé sur TU de manière que $QUVW$ soit un carré et que $PWVT$ et $RSTU$ soient des rectangles.

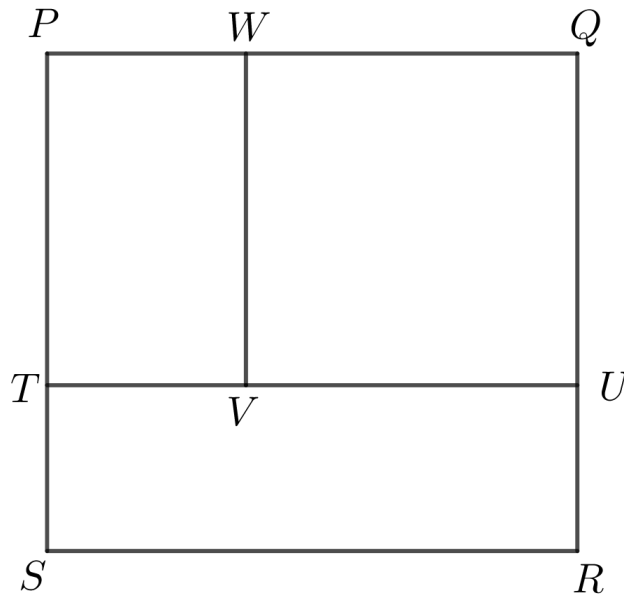

Le carré $PQRS$ a des côtés de longueur 9 cm et

$$\text{l'aire de } QUVW - \text{l'aire de } RSTU = \text{l'aire de } RSTU - \text{l'aire de } PWVT$$

Si le carré $QUVW$ a des côtés de longueur x cm, détermine la valeur de x ainsi que les aires des rectangles $PWVT$ et $RSTU$.



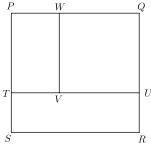

Problem of the Week

Problem D and Solution

Square Parts

Problem

Square $PQRS$ has W on PQ , U on QR , T on PS , and V on TU such that $QUVW$ is a square, and $PWVT$ and $RSTU$ are rectangles.

The side length of square $PQRS$ is 9 cm, and

$$\text{area of } QUVW - \text{area of } RSTU = \text{area of } RSTU - \text{area of } PWVT$$

If square $QUVW$ has side length equal to x cm, determine the value of x and the areas of rectangles $PWVT$ and $RSTU$.

Solution

We know $SR = PQ = 9$ cm and $WQ = QU = x$ cm.

Therefore, $PW = PQ - WQ = (9 - x)$ cm. Similarly, $UR = (9 - x)$ cm.

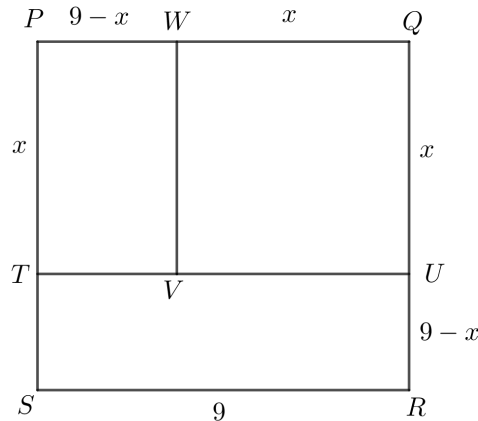

Thus, we have that the area of $QUVW$ is equal to x^2 cm², the area of $RSTU$ is equal to $9(9 - x)$ cm², and the area of $PWVT$ is equal to $x(9 - x)$ cm².

Therefore, we know that

$$\begin{aligned} \text{area of } QUVW - \text{area of } RSTU &= \text{area of } RSTU - \text{area of } PWVT \\ x^2 - 9(9 - x) &= 9(9 - x) - x(9 - x) \\ x^2 - 81 + 9x &= 81 - 9x - 9x + x^2 \\ 27x &= 162 \\ x &= 6 \end{aligned}$$

Therefore, $x = 6$ cm, the area of $PWVT$ is equal to $x(9 - x) = 6(9 - 6) = 18$ cm², and the area of $RSTU = 9(9 - x) = 9(9 - 6) = 27$ cm².



Problème de la semaine

Problème D

Boîtes de beignes

Une boulangerie-pâtisserie est connue pour ses beignes uniques. Lors d'une fin de semaine, trois délicieuses saveurs étaient à l'honneur, chacune étant proposée dans sa propre boîte. Les beignes saveur pêche-caramel se vendaient dans de petites boîtes de 3 beignes chacune, ceux au chocolat dans des boîtes moyennes de 4 beignes chacune et les beignes arc-en-ciel se vendaient dans de grandes boîtes de 8 beignes chacune.

Une fois la fin de semaine terminée, le gérant a déterminé qu'ils avaient vendu 68 boîtes de beignes au total. De plus, un nombre égal de beignes de chaque saveur a été vendu. Combien de beignes la boulangerie-pâtisserie a-t-elle vendus au total ?





Problem of the Week

Problem D and Solution

Boxes of Doughnuts

Problem

A bakery is famous for its specialty doughnuts. One weekend they had three flavours available, each packaged in boxes. Peach caramel doughnuts were sold in small boxes with 3 doughnuts per box, chocolate fudge doughnuts were sold in medium boxes with 4 doughnuts per box, and rainbow doughnuts were sold in large boxes with 8 doughnuts per box.

At the end of the weekend, the owner calculated that they sold 68 boxes of doughnuts in total. Also an equal number of doughnuts of each flavour were sold. How many doughnuts did they sell in total?

Solution

Solution 1

Let n represent the number of doughnuts of each flavour sold. Since there were 3 peach caramel doughnuts per box, then n must be divisible by 3. Since there were 4 chocolate fudge doughnuts per box, then n must be divisible by 4. Since there were 8 rainbow doughnuts per box, then n must be divisible by 8.

Therefore, n must be divisible by 3, 4, and 8. The smallest number divisible by 3, 4, and 8 is 24. (This number is called the *least common multiple* or *LCM*).

If there were 24 doughnuts of each flavour sold, there would have been $24 \div 3 = 8$ boxes of peach caramel doughnuts, $24 \div 4 = 6$ boxes of chocolate fudge doughnuts, and $24 \div 8 = 3$ boxes of rainbow doughnuts. This would mean $8 + 6 + 3 = 17$ boxes of doughnuts would have been sold in total. However, we know that 68 boxes of doughnuts were sold, and since $68 = 17 \times 4$, it follows that 4 times as many doughnuts were sold. Therefore, $24 \times 4 = 96$ doughnuts of each flavour were sold. Thus, the total number of doughnuts sold was $96 \times 3 = 288$.

We can check the correctness of this solution. Since there were 3 peach caramel doughnuts per box, then there were $96 \div 3 = 32$ boxes of peach doughnuts sold. Since there were 4 chocolate fudge doughnuts per box, then there were $96 \div 4 = 24$ boxes of chocolate fudge doughnuts sold. Since there were 8 rainbow doughnuts per box, then there were $96 \div 8 = 12$ boxes of rainbow doughnuts sold. The total number of boxes sold was therefore $32 + 24 + 12 = 68$, as expected.

Solution 2

This solution uses algebra and equation solving. Let n represent the number of doughnuts of each flavour sold. Since there were 3 peach caramel doughnuts per box, then $\frac{n}{3}$ boxes of peach caramel doughnuts were sold. Since there were 4



chocolate fudge doughnuts per box, then $\frac{n}{4}$ boxes of chocolate fudge doughnuts were sold. Since there were 8 rainbow doughnuts per box, then $\frac{n}{8}$ boxes of rainbow doughnuts were sold. Since 68 boxes of doughnuts were sold in total,

$$\begin{aligned}\frac{n}{3} + \frac{n}{4} + \frac{n}{8} &= 68 \\ \frac{8n}{24} + \frac{6n}{24} + \frac{3n}{24} &= 68 \\ \frac{17n}{24} &= 68 \\ 17n &= 68 \times 24 \\ 17n &= 1632 \\ n &= \frac{1632}{17} = 96\end{aligned}$$

Therefore, 96 doughnuts of each flavour were sold. Thus, the total number of doughnuts sold was $96 \times 3 = 288$.

Solution 3

This solution uses ratios. Let n represent the number of doughnuts of each flavour sold. The ratio of the number of boxes of rainbow doughnuts to peach caramel doughnuts sold is

$$\frac{n}{8} : \frac{n}{3} = \frac{3n}{24} : \frac{8n}{24} = 3n : 8n = 3 : 8$$

Similarly, the ratio of the number of boxes of peach caramel doughnuts to chocolate fudge doughnuts sold is $4 : 3 = 8 : 6$. So the ratio of the number of boxes of rainbow doughnuts to peach caramel doughnuts to chocolate fudge doughnuts sold is $3 : 8 : 6$. Let the number of boxes of rainbow doughnuts be $3k$, the number of boxes of peach caramel doughnuts be $8k$, and the number of boxes of chocolate fudge doughnuts be $6k$. Since 68 boxes of doughnuts were sold in total,

$$\begin{aligned}3k + 8k + 6k &= 68 \\ 17k &= 68 \\ k &= \frac{68}{17} = 4\end{aligned}$$

It follows that the number of boxes of rainbow doughnuts sold was $3 \times 4 = 12$, so the number of rainbow doughnuts sold was $12 \times 8 = 96$. Therefore $n = 96$, so 96 doughnuts of each flavour were sold. Thus, the total number of doughnuts sold was $96 \times 3 = 288$.



Problème de la semaine

Problème D

Chiffres en solde !

La Quincaillerie d'Helena liquide un style particulier de chiffres utilisés pour les numéros de maison. Actuellement, il ne reste que cinq 5, quatre 4, trois 3 et deux 2.

Combien de numéros de maison différents à trois chiffres peut-on créer à partir de ces chiffres?

5 5 5 5 5
4 4 4 4
3 3 3
2 2



55555
4444
333
22

Problem of the Week

Problem D and Solution

Number Display

Problem

Helena's Hardware Store is clearing out a particular style of single digits that are used for house numbers. There are currently only five 5s, four 4s, three 3s, and two 2s left.

How many different three-digit house numbers can be made using these single digits?

Solution

Solution 1

Let's suppose that there were three or more 2s available. For the first digit, the customer could choose from the digits 5, 4, 3, and 2. Therefore, there would be 4 choices for the first digit. Similarly, there would be 4 choices for the second digit, and 4 choices for the third digit. This would give $4 \times 4 \times 4 = 64$ possible three-digit house numbers that could be made.

However, there are actually only two 2s available, so not all of these house numbers can be made. In particular, the house number 222 cannot be made, but all others can.

Therefore, $64 - 1 = 63$ different three-digit house numbers can be made using these single digits.

Solution 2

Let's look at three different cases.

Case 1: All three digits in the house number are the same

The house number could then be 555, 444, or 333. The number 222 cannot be made since only two 2s are available. Therefore, there are 3 three-digit house numbers with all three digits the same.

Case 2: Two digits are the same and the third digit is different

There are 4 choices for the digits that are the same, namely 5, 4, 3, and 2. For each of these possible choices, there are 3 choices for the third different digit. For example, if two of the digits are 5, then the third digit could be 4, 3, or 2. Therefore, there are $4 \times 3 = 12$ ways to choose the digits. For each of these choices, there are 3 ways to arrange the digits. For example, suppose the digits are a , a , and b . The house number could be aab , aba , or baa . Therefore, there are $12 \times 3 = 36$ three-digit house numbers with two digits the same and one different.

Case 3: All three digits are different

The customer has 4 choices for the first digit, namely 5, 4, 3, or 2. Once that digit is chosen, there are 3 choices for the second digit. Once the first and second digits are chosen, there are 2 choices for the third digit. Therefore, there are $4 \times 3 \times 2 = 24$ three-digit house numbers with all three digits different.

Therefore, $3 + 36 + 24 = 63$ different three-digit house numbers can be made using these single digits.



Problème de la semaine

Problème D

En quête de l'angle x

Un cercle de centre C a un diamètre PQ et un rayon CS . La corde PR coupe le rayon CS et la corde SQ , respectivement en A et en B . Si $\angle CAP = 90^\circ$, $\angle RPQ = 24^\circ$ et $\angle QBR = x^\circ$, détermine la valeur de x .

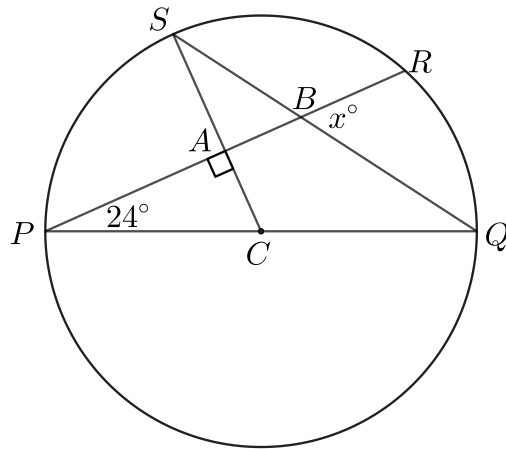



Problem of the Week

Problem D and Solution

Find that Angle

Problem

A circle with centre C has a diameter PQ and radius CS . Chord PR intersects CS and chord SQ at A and B , respectively. If $\angle CAP = 90^\circ$, $\angle RPQ = 24^\circ$, and $\angle QBR = x^\circ$, then determine the value of x .

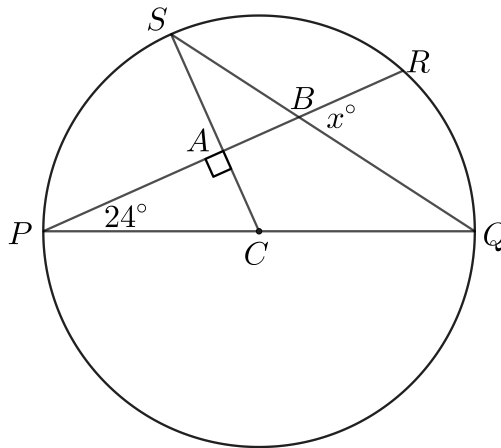

Solution

Solution 1

Since the angles in a triangle sum to 180° , in $\triangle CAP$, $\angle ACP = 180^\circ - 90^\circ - 24^\circ = 66^\circ$.

Since PQ is a diameter, PCQ is therefore a straight line. Thus, $\angle ACP + \angle QCS = 180^\circ$, and so $\angle QCS = 180^\circ - \angle ACP = 180^\circ - 66^\circ = 114^\circ$.

Since CS and CQ are radii of the circle, we have $CS = CQ$. It follows that $\triangle CSQ$ is isosceles and $\angle CQS = \angle CSQ$. Since the angles in a triangle sum to 180° , we have $\angle CSQ + \angle CQS + \angle QCS = 180^\circ$, and since $\angle CQS = \angle CSQ$, this gives

$$2\angle CSQ + 114^\circ = 180^\circ$$

$$2\angle CSQ = 66^\circ$$

$$\angle CSQ = 33^\circ$$

Opposite angles are equal, so it follows that $\angle SBA = \angle QBR = x^\circ$ and $\angle SAB = \angle CAP = 90^\circ$.

In $\triangle ABS$, $\angle SBA + \angle SAB + \angle ASB = 180^\circ$. Since $\angle ASB = \angle CSQ = 33^\circ$, we have

$$x^\circ + 90^\circ + 33^\circ = 180^\circ$$

$$x + 123 = 180$$

$$x = 57$$

Therefore, $x = 57$.



Solution 2

This solution will use the *exterior angle theorem*. In a triangle, the angle formed at a vertex between one side of the triangle and the extension of the other side of the triangle is called an exterior angle.

The exterior angle theorem states that the measure of an exterior angle of a triangle is equal to the sum of the two opposite interior angles.

For example, in the diagram shown, $\angle XZW$ is exterior to $\triangle XYZ$. The exterior angle theorem states that $r^\circ = p^\circ + q^\circ$.

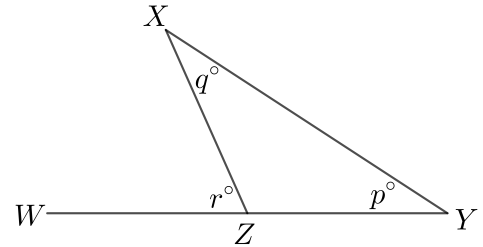

Since the angles in a triangle sum to 180° , in $\triangle CAP$, $\angle ACP = 180^\circ - 90^\circ - 24^\circ = 66^\circ$.

Since CS and CQ are radii of the circle, we have $CS = CQ$. It follows that $\triangle CSQ$ is isosceles and $\angle CQS = \angle CSQ$. Since $\angle ACP$ is exterior to $\triangle CSQ$, by the exterior angle theorem,

$$\begin{aligned} \angle ACP &= \angle CQS + \angle CSQ \\ 66^\circ &= 2\angle CQS \\ \angle CSQ &= 33^\circ \end{aligned}$$

Since $\angle QBR$ is exterior to $\triangle BQP$, by the exterior angle theorem, $\angle QBR = \angle BPQ + \angle BQP$. Since $\angle QBR = x^\circ$, $\angle BPQ = \angle RPQ$ (same angle), and $\angle BQP = \angle CQS$ (same angle), this gives

$$\begin{aligned} x^\circ &= \angle RPQ + \angle CQS \\ x &= 24 + 33 \\ x &= 57 \end{aligned}$$

Therefore, $x = 57$.

Solution 3

This solution uses the *exterior angle theorem* from Solution 2, as well as the *angle subtended by an arc theorem*. This theorem states that the measure of the angle subtended by an arc at the centre is equal to two times the measure of the angle subtended by the same arc at any point on the remaining part of the circle.

Since $\angle SCP$ is the angle at the centre subtended by arc SP , and $\angle SQP$ is an angle subtended by that same arc but on the circle, we know that $\angle SCP = 2\angle SQP$.

Since the angles in a triangle sum to 180° , in $\triangle CAP$, $\angle ACP = 180^\circ - 90^\circ - 24^\circ = 66^\circ$. Thus, since $\angle SCP = \angle ACP$ (same angle), we have $\angle SCP = \angle ACP = 66^\circ$. Therefore, $\angle SCP = 2\angle SQP$ gives $66^\circ = 2\angle SQP$, and thus $\angle SQP = 33^\circ$.

Since $\angle QBR$ is exterior to $\triangle BQP$, by the exterior angle theorem, $\angle QBR = \angle BPQ + \angle BQP$. Since $\angle QBR = x^\circ$, $\angle BPQ = \angle RPQ$ (same angle), and $\angle BQP = \angle SQP$ (same angle), this gives

$$\begin{aligned} x^\circ &= \angle RPQ + \angle SQP \\ x &= 24 + 33 \\ x &= 57 \end{aligned}$$

Therefore, $x = 57$.



Problème de la semaine

Problème D

Découpe équilibrée

Quatre segments de droites sont tracés sur un morceau de papier rectangulaire de manière à être parallèles au bord supérieur du papier:

- Le segment A mesure 4 cm de long et son extrémité gauche touche le bord gauche du papier.
- Le segment B mesure 3 cm de long et son extrémité gauche est située à 3 cm du bord gauche du papier.
- Le segment C mesure 6 cm de long et son extrémité gauche est située à 1,5 cm du bord gauche du papier.
- Le segment D mesure 4 cm de long et son extrémité gauche est située à 1 cm du bord gauche du papier.

Il est possible de découper le papier le long d'une ligne pointillée, L , parallèle au bord gauche du papier et passant à travers chacun des quatre segments, de sorte que la longueur totale des morceaux des quatre segments de droites de chaque côté de la découpe soit la même.

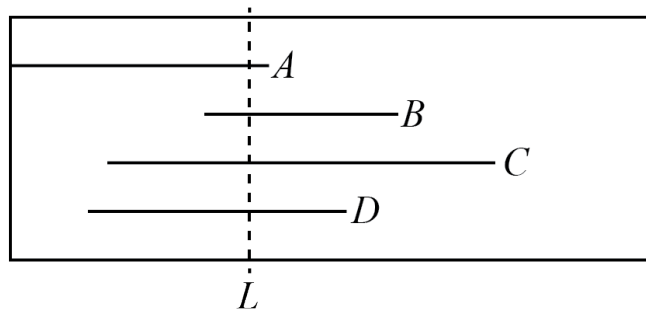

Quelle est la longueur, en cm, de la partie du segment de droite A qui est située à gauche de la découpe ?



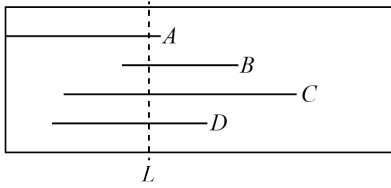

Problem of the Week

Problem D and Solution

Making the Cut

Problem

Four line segments are drawn on a rectangular piece of paper, parallel to the top edge of the paper, as follows:

- Line segment A is 4 cm long and its left end touches the left edge of the paper.
- Line segment B is 3 cm long and its left end is 3 cm from the left edge of the paper.
- Line segment C is 6 cm long and its left end is 1.5 cm from the left edge of the paper.
- Line segment D is 4 cm long and its left end is 1 cm from the left edge of the paper.

The paper can be cut along a dotted line, L , parallel to the left edge of the paper and through each of the four line segments so that the total length of the pieces of the four line segments on each side of the cut is the same. What is the length, in cm, of the part of line segment A to the left of the cut?

Solution

Suppose the distance from the left edge of the paper to line L is d cm. Then the length of the part of line segment A to the left of the cut is d cm.

Since line segment B is 3 cm from the left edge of the paper, then the length of the part of line segment B to the left of the cut is $(d - 3)$ cm. Similarly, the lengths of the parts of line segments C and D to the left of the cut are $(d - 1.5)$ cm and $(d - 1)$ cm, respectively.

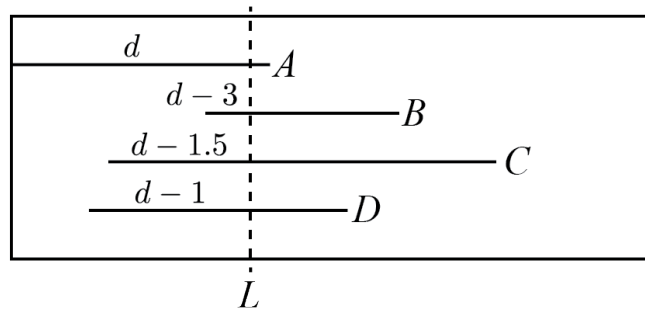

Therefore, the total length of the four line segments to the left of the cut is

$$d + (d - 3) + (d - 1.5) + (d - 1) = (4d - 5.5) \text{ cm.}$$

From here we proceed with two different solutions.

**Solution 1**

Since the total length of the four line segments on each side of the cut is the same, that means the total length of the four line segments on the left of the cut is equal to half of the total length of the four line segments, which is $\frac{1}{2}(4 + 3 + 6 + 4) = 8.5$ cm.

Thus, $4d - 5.5 = 8.5$, or $4d = 14$, or $d = 3.5$.

Therefore, the length of the part of line segment A to the left of the cut is 3.5 cm.

Solution 2

Since line segment A is 4 cm long and d cm of it is to the left of the cut, it follows that $(4 - d)$ cm of line segment A is to the right of the cut. Since line segment B is 3 cm long and $(d - 3)$ cm of it is to the left of the cut, it follows that $3 - (d - 3) = (6 - d)$ cm is to the right of the cut. Since line segment C is 6 cm long and $(d - 1.5)$ cm of it is to the left of the cut, it follows that $6 - (d - 1.5) = (7.5 - d)$ cm is to the right of the cut. Since line segment D is 4 cm long and $(d - 1)$ cm of it is to the left of the cut, it follows that $4 - (d - 1) = (5 - d)$ cm is to the right of the cut.

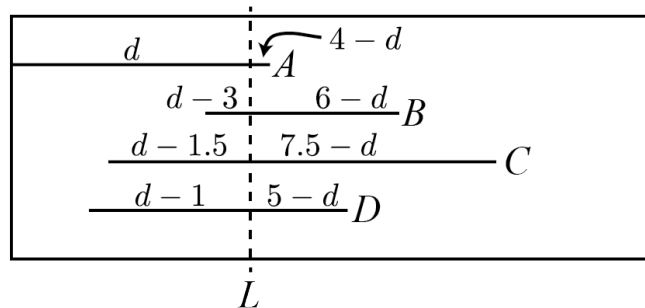

Therefore, the total length of the four line segments to the right of the cut is

$$(4 - d) + (6 - d) + (7.5 - d) + (5 - d) = (22.5 - 4d) \text{ cm}$$

Since the total length of the four line segments on each side of the cut is the same,

$$4d - 5.5 = 22.5 - 4d$$

$$8d = 28$$

$$d = 3.5$$

Therefore, the length of the part of line segment A to the left of the cut is 3.5 cm.



Problème de la semaine

Problème D

Quelques cents

Carroll et Arthur ont nettoyé leur maison et ont trouvé un total de 33 pièces de monnaie. Les pièces étaient soit des pièces de 5 cents, soit des pièces de 10 cents, soit des pièces de 25 cents. Il y avait deux fois plus de pièces de 25 cents que de pièces de 10 cents et la valeur totale de toutes les pièces qu'ils ont trouvées était de 5,25 \$.

Combien ont-ils trouvé de chaque type de pièce ?



NOTE : Au Canada, 100 cents équivalent 1 \$.





Problem of the Week

Problem D and Solution

Small Change

Problem

Carroll and Arthur cleaned their house and found a total of 33 coins. The coins were either nickels (5 cent coins), dimes (10 cent coins), or quarters (25 cent coins). There were twice as many quarters as dimes, and the total value of all the coins they found was \$5.25.

How many of each type of coin did they find?

NOTE: In Canada, 100 cents is equal to \$1.

Solution

Let n be the number of nickels, d be the number of dimes, and q be the number of quarters.

From the total number of coins we get the equation

$$n + d + q = 33 \quad (1)$$

From the value of the coins we get the equation

$$5n + 10d + 25q = 525 \quad (2)$$

We also know that $q = 2d$.

Substituting $q = 2d$ into equation (1) and simplifying, we get

$$\begin{aligned} n + d + 2d &= 33 \\ n + 3d &= 33 \end{aligned} \quad (3)$$

Substituting $q = 2d$ into equation (2) and simplifying, we get

$$\begin{aligned} 5n + 10d + 25(2d) &= 525 \\ 5n + 60d &= 525 \\ n + 12d &= 105 \end{aligned} \quad (4)$$

We can isolate n in equation (3) to get $n = 33 - 3d$.

Similarly, we can isolate n in equation (4) to get $n = 105 - 12d$.

Since $n = n$, it follows that

$$\begin{aligned} 33 - 3d &= 105 - 12d \\ -3d + 12d &= 105 - 33 \\ 9d &= 72 \\ d &= 8 \end{aligned}$$

Substituting $d = 8$ into $n = 33 - 3d$, it follows that $n = 33 - 3(8) = 33 - 24 = 9$.

Finally, we substitute $d = 8$ into $q = 2d$, to find $q = 2(8) = 16$.

Therefore, they found 9 nickels, 8 dimes, and 16 quarters.



Problème de la semaine

Problème D

Chevauchement 2

Selena dessine le carré $ABCD$ dont les côtés mesurent 16 cm. Endre dessine ensuite le triangle AED sur le carré $ABCD$ de manière que :

- les côtés AE et DE touchent BC en F et G respectivement et
- l'aire du triangle AED est le double de l'aire du carré $ABCD$.

Détermine l'aire du trapèze $AFGD$.

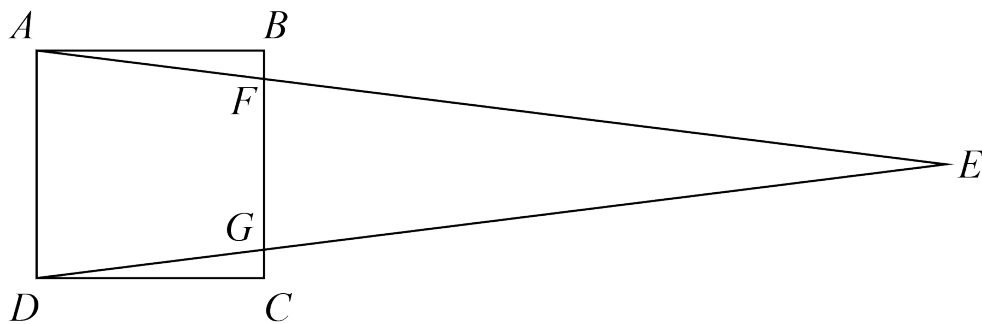

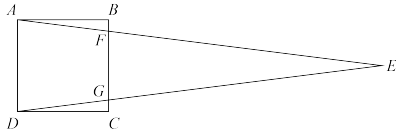

Problem of the Week

Problem D and Solution

Overlapping Shapes 2

Problem

Selena draws square $ABCD$ with side length 16 cm. Endre then draws $\triangle AED$ on top of square $ABCD$ so that

- sides AE and DE meet BC at F and G , respectively, and
- the area of $\triangle AED$ is twice the area of square $ABCD$.

Determine the area of trapezoid $AFGD$.

Solution

We construct an altitude of $\triangle AED$ from E , intersecting AD at P and BC at Q . Since $ABCD$ is a square, we know that AD is parallel to BC . Therefore, since PE is perpendicular to AD , QE is perpendicular to FG and thus an altitude of $\triangle FEG$.

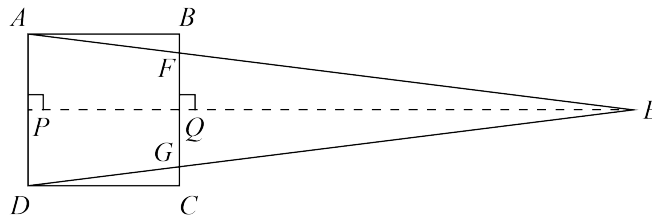

The area of square $ABCD$ is $16 \times 16 = 256 \text{ cm}^2$. Since the area of $\triangle AED$ is twice the area of square $ABCD$, it follows that the area of $\triangle AED$ is $2 \times 256 = 512 \text{ cm}^2$.

We also know that

$$\begin{aligned} \text{Area } \triangle AED &= AD \times PE \div 2 \\ 512 &= 16 \times PE \div 2 \\ 512 &= 8 \times PE \\ PE &= 512 \div 8 \\ &= 64 \text{ cm} \end{aligned}$$

Since $\angle APQ = 90^\circ$, we know that $ABQP$ is a rectangle, and so $PQ = AB = 16$ cm. We also know that $PE = PQ + QE$. Since $PE = 64$ cm and $PQ = 16$ cm, it follows that $QE = PE - PQ = 64 - 16 = 48$ cm.

From here we proceed with two different solutions.



Solution 1

We will use the relationships between the areas of the shapes to determine the length of FG .

$$\begin{aligned}\text{Area of trapezoid } AFGD + \text{Area } \triangle FEG &= \text{Area } \triangle AED \\ (AD + FG) \times AB \div 2 + FG \times QE \div 2 &= 512 \\ (16 + FG) \times 16 \div 2 + FG \times 48 \div 2 &= 512 \\ (16 + FG) \times 8 + 24 \times FG &= 512 \\ 128 + 8FG + 24FG &= 512 \\ 32FG &= 384 \\ FG &= 12 \text{ cm}\end{aligned}$$

Now we can use FG to calculate the area of trapezoid $AFGD$.

$$\begin{aligned}\text{Area of trapezoid } AFGD &= (AD + FG) \times AB \div 2 \\ &= (16 + 12) \times 16 \div 2 \\ &= 28 \times 8 = 224 \text{ cm}^2\end{aligned}$$

Therefore, the area of trapezoid $AFGD$ is 224 cm^2 .

Solution 2

We will use similar triangles to determine the length of FG . We know that $\angle AED = \angle FEG$. Also, since AD is parallel to FG it follows that $\angle EAD$ and $\angle EFG$ are corresponding angles, so are equal. Thus, by angle-angle similarity, $\triangle AED \sim \triangle FEG$. Therefore,

$$\begin{aligned}\frac{AD}{PE} &= \frac{FG}{QE} \\ \frac{16}{64} &= \frac{FG}{48} \\ \frac{1}{4} &= \frac{FG}{48} \\ FG &= 48 \times \frac{1}{4} = 12 \text{ cm}\end{aligned}$$

Now we can use FG to calculate the area of trapezoid $AFGD$.

$$\begin{aligned}\text{Area of trapezoid } AFGD &= (AD + FG) \times AB \div 2 \\ &= (16 + 12) \times 16 \div 2 \\ &= 28 \times 8 = 224 \text{ cm}^2\end{aligned}$$

Therefore, the area of trapezoid $AFGD$ is 224 cm^2 .



Problème de la semaine

Problème D

La même puissance

Parfois, deux puissances qui n'ont pas la même base ont tout de même des valeurs égales. Par exemple, $9^3 = 27^2$ et $(-5)^4 = 25^2$.

Si x et y sont des nombres entiers, trouve tous les couples (x, y) qui vérifient l'équation

$$(x - 1)^{x+y} = 8^2$$

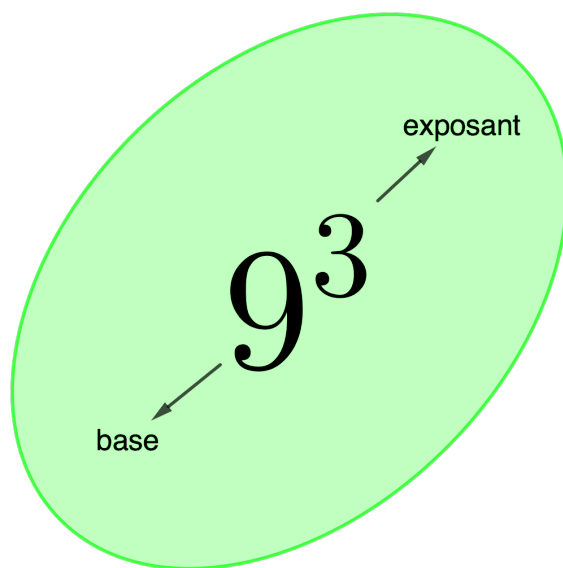

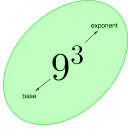

Problem of the Week

Problem D and Solution

The Same Power

Problem

Sometimes two powers that are not written with the same base are still equal in value. For example, $9^3 = 27^2$ and $(-5)^4 = 25^2$.

If x and y are integers, find all ordered pairs (x, y) that satisfy the equation

$$(x - 1)^{x+y} = 8^2$$

Solution

Since $8^2 = 64$, we want to look at how we can express 64 as a^b where a and b are integers. There are six ways to do so. We can do so as 64^1 , 8^2 , 4^3 , 2^6 , $(-2)^6$, and $(-8)^2$.

We use these powers and the expression $(x - 1)^{x+y}$ to find values for x and y .

- The power $(x - 1)^{x+y}$ is expressed as 64^1 when $x - 1 = 64$ and $x + y = 1$. Then $x = 65$ and $y = -64$ follows. Thus $(65, -64)$ is one pair.
- The power $(x - 1)^{x+y}$ is expressed as 8^2 when $x - 1 = 8$ and $x + y = 2$. Then $x = 9$ and $y = -7$ follows. Thus $(9, -7)$ is one pair.
- The power $(x - 1)^{x+y}$ is expressed as 4^3 when $x - 1 = 4$ and $x + y = 3$. Then $x = 5$ and $y = -2$ follows. Thus $(5, -2)$ is one pair.
- The power $(x - 1)^{x+y}$ is expressed as 2^6 when $x - 1 = 2$ and $x + y = 6$. Then $x = 3$ and $y = 3$ follows. Thus $(3, 3)$ is one pair.
- The power $(x - 1)^{x+y}$ is expressed as $(-2)^6$ when $x - 1 = -2$ and $x + y = 6$. Then $x = -1$ and $y = 7$ follows. Thus $(-1, 7)$ is one pair.
- The power $(x - 1)^{x+y}$ is expressed as $(-8)^2$ when $x - 1 = -8$ and $x + y = 2$. Then $x = -7$ and $y = 9$ follows. Thus $(-7, 9)$ is one pair.

Therefore, there are six ordered pairs that satisfy the equation.

They are $(65, -64)$, $(9, -7)$, $(5, -2)$, $(3, 3)$, $(-1, 7)$, and $(-7, 9)$.



Raisonnement informatiques (C)

Amène-moi à la
couverture



Problème de la semaine

Problème D

Énigme électrique

Seize cabanes se trouvent dans une grande forêt et chaque cabane est reliée à au moins deux autres cabanes par des sentiers pédestres, comme dans la figure ci-dessous. Deux cabanes sont dites *voisines* si elles sont directement reliées par un segment de sentier. Après une grande tempête, chaque résident s'est rendu chez tous ses voisins pour leur demander s'ils avaient eu ou non une coupure de courant. Dans la figure, le numéro sur chaque cabane indique le nombre de cabanes voisines qui n'ont pas eu une coupure de courant.

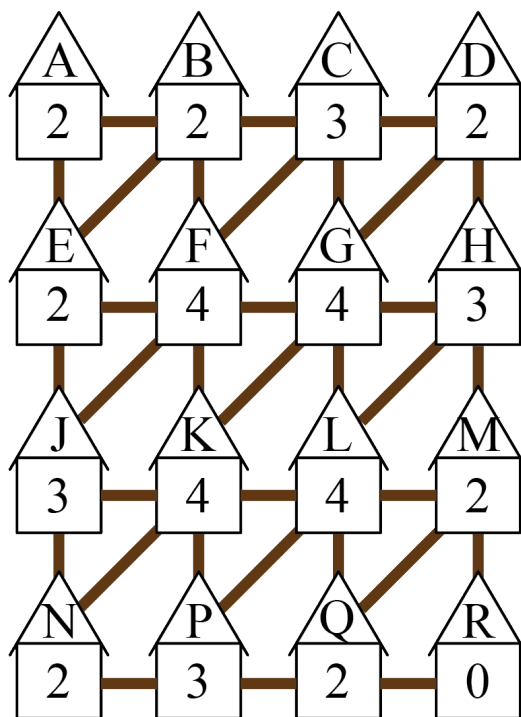

Détermine lesquelles des cabanes n'ont pas eu une coupure de courant.

Tu n'arrives pas à imprimer cette page ? Essaie notre [feuille de travail interactive](#).

Ce problème s'inspire d'un autre problème qui figurait dans un des concours précédents du [défi informatique Beaver](#).



Problem of the Week Problem D and Solution

Power Puzzle

Problem

Sixteen cabins are in a large forest, and each cabin is connected to at least two of the other cabins by walking trails, as shown in the diagram. Two cabins are said to be *neighbours* if they are directly connected by a trail segment. After a big storm, each resident walked to each of their neighbours houses to ask whether or not they had lost power. In the diagram, the number on each cabin indicates the number of its neighbours who still had power after the storm.

Determine which cabins still have power after the storm.

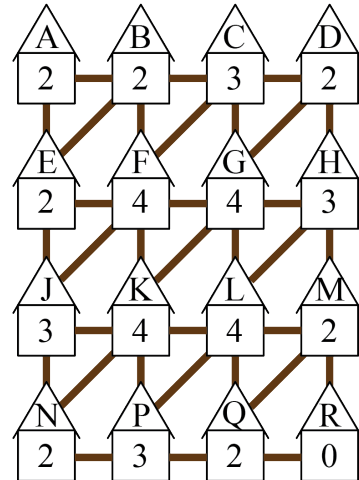

Not printing this page? You can use our [interactive worksheet](#).

This problem was inspired by a past [Beaver Computing Challenge \(BCC\)](#) problem.

Solution

We begin by looking at cabin *A*. Since its neighbours are cabins *B* and *E*, and 2 of its neighbours still have power, it follows that both cabins *B* and *E* still have power. We place a lit lightbulb (💡) at each of *B* and *E* to log this information in the diagram.

Next, looking at cabin *R*, none of its neighbours still have power. Since its neighbours are cabins *M* and *Q*, it follows that both of these cabins lost power (💡).

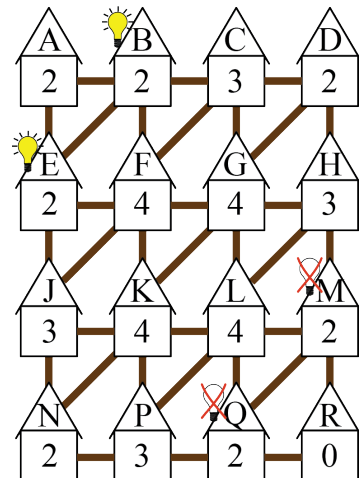

Cabin *H* is neighbours with cabins *D*, *G*, *L*, and *M*. Since 3 of these neighbours still have power, and we already determined that cabin *M* lost power, it follows that cabins *D*, *G*, and *L* all still have power.

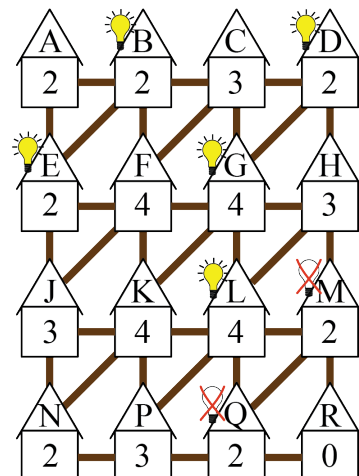



Cabin *C* is neighbours with cabins *B*, *D*, *F*, and *G*. Since 3 of these neighbours still have power, and we already determined that cabins *B*, *D*, and *G* still have power, it follows that cabin *F* lost power.

Cabin *J* is neighbours with cabins *E*, *F*, *K*, and *N*. Since 3 of these neighbours still have power, and we already determined that cabin *E* still has power and cabin *F* lost power, it follows that cabins *K* and *N* still have power.

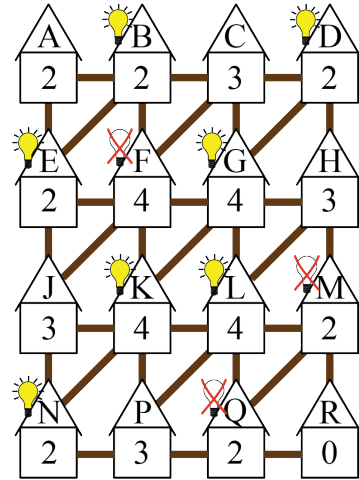

Cabin *F* is neighbours with cabins *B*, *C*, *E*, *G*, *J*, and *K*. Since 4 of these cabins still have power, and we already determined that cabins *B*, *E*, *G*, and *K* still have power, it follows that the remaining two cabins, namely *C* and *J*, must have lost power.

Cabin *D* is neighbours with cabins *C*, *G*, and *H*. Since 2 of these cabins still have power, and we already determined that cabin *C* lost power and cabin *G* still has power, it follows that cabin *H* still has power.

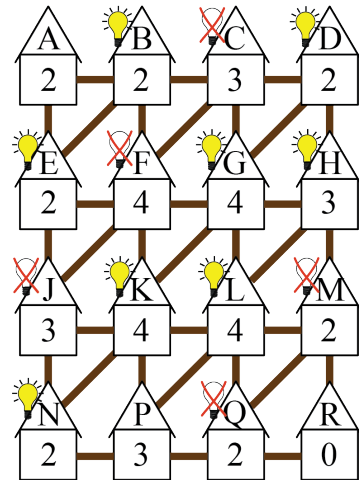

Cabin *B* is neighbours with cabins *A*, *C*, *E*, and *F*. Since 2 of these cabins still have power, and we already determined that cabin *E* still has power and cabins *C* and *F* lost power, it follows that cabin *A* still has power.

Cabin *N* is neighbours with cabins *J*, *K*, and *P*. Since 2 of these cabins still have power, and we already determined that cabin *J* lost power and cabin *K* still has power, it follows that cabin *P* still has power.

Cabin *M* is neighbours with cabins *H*, *L*, *Q*, and *R*. Since 2 of these cabins still have power, and we already determined that cabins *H* and *L* still have power and cabin *Q* lost power, it follows that cabin *R* lost power.

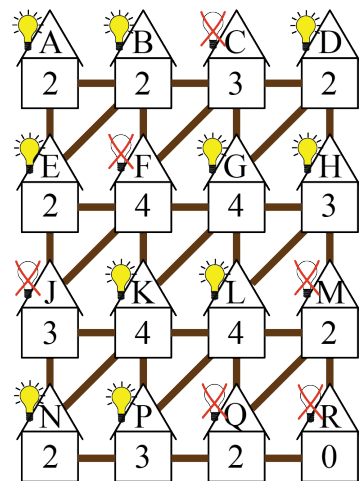

Thus, cabins *A*, *B*, *D*, *E*, *G*, *H*, *K*, *L*, *N*, and *P* still have power.



Problème de la semaine

Problème D

Labyrinthe de maïs suivant

Ezra se rend à une ferme locale pour parcourir un labyrinthe de maïs. La carte du labyrinthe est présentée dans la figure ci-dessous.

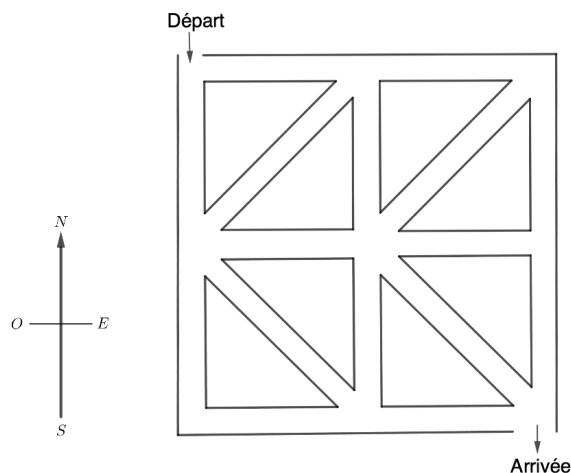

Le jour de sa visite, la ferme impose certaines règles : il ne peut se déplacer qu'en direction du sud, de l'est, du sud-est ou du sud-ouest le long des chemins.

Compte tenu de ces restrictions, combien de parcours différents peut-il emprunter pour aller du point de départ jusqu'à l'arrivée ?



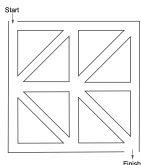

Problem of the Week

Problem D and Solution

Next Corn Maze

Problem

Ezra goes to a local farm to do a corn maze. The map of the corn maze is given.

On the day he arrives, the farm has the restrictions that he can only travel south, east, southeast, or southwest along a path. Using these restrictions, how many different routes can he take from Start to Finish?

Solution

We label the Start with the letter S and the Finish with the letter F . We label the other seven intersections in the maze as A , B , C , D , E , G , and H , as shown. We also place arrows on the paths to show the direction in which Ezra can travel.

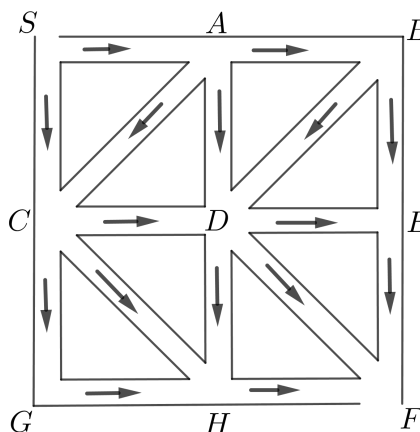

We will count the number of routes from S to each intersection, and keep track of this information by placing a number at each intersection.

Since you can only travel south, east, southeast, or southwest along a path, from S there is only one route to A and only one route to B . Therefore, we place a 1 at intersection A to keep track of the number of routes from S to A . We also place a 1 at intersection B to keep track of the number of routes from S to B .

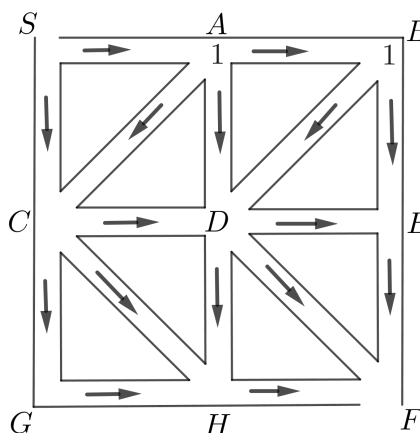



To get to intersection C , Ezra could travel directly from S or through A . Since there is only 1 route from S to A , there are 2 routes from S to C . We place a 2 at intersection C .

To get to D , Ezra must travel from either A , B , or C . Therefore, the total number of routes from S to D is equal to the number of routes from S to A , plus the number of routes from S to B , plus the number of routes from S to C , or $1 + 1 + 2 = 4$. We place a 4 at intersection D .

To get to E , Ezra must travel from either B or D . Therefore, the total number of routes from S to E is equal to the number of routes from S to B plus the number of routes from S to D , or $1 + 4 = 5$. We place a 5 at intersection E .

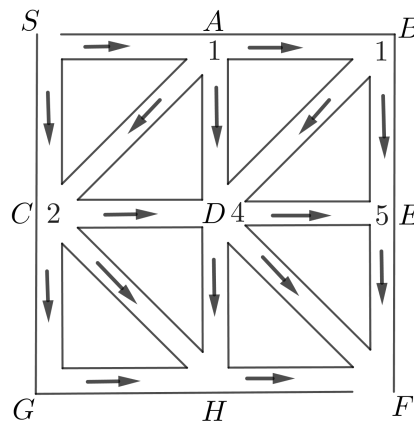

To get to intersection G , Ezra must travel from C . Therefore, there are only 2 routes from S to G , and we place a 2 at G .

To get to intersection H , Ezra must travel from either C , D , or G . Therefore, the total number of routes from S to H is equal to $2 + 4 + 2 = 8$. We place an 8 at H .

Finally, to get to intersection F , Ezra must travel from either D , E , or H . Therefore, the total number of routes from S to F is equal to $4 + 5 + 8 = 17$. We place a 17 at F .

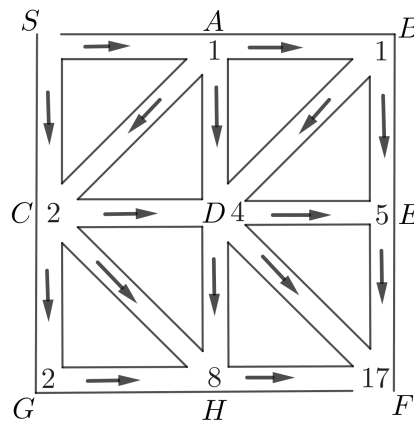

Therefore, there are a total of 17 different routes that Ezra can take from Start to Finish.



Problème de la semaine

Problème D

Année bissextile 2

La plupart des gens croient qu'une année compte 365 jours, mais en réalité, elle en compte légèrement plus. Pour ajuster ce surplus de temps, on a recours aux années bissextiles. Ces dernières sont des années qui contiennent un jour de plus.

Mara utilise l'organigramme ci-contre pour déterminer si une année donnée est bissextile ou non. D'après l'organigramme :

- l'année 2018 n'était **pas** une année bissextile car 2018 n'est pas divisible par 4.
- l'année 2016 était une année bissextile car 2016 est divisible par 4, mais n'est pas divisible par 100.
- l'année 2100 ne sera **pas** une année bissextile car 2100 est divisible par 4 et par 100, mais n'est pas divisible par 400.
- l'année 2000 était une année bissextile car 2000 est divisible par 4, par 100 et par 400.

Si Mara choisit au hasard une année après l'an 2000, quelle est la probabilité pour qu'elle choisisse une année bissextile ?

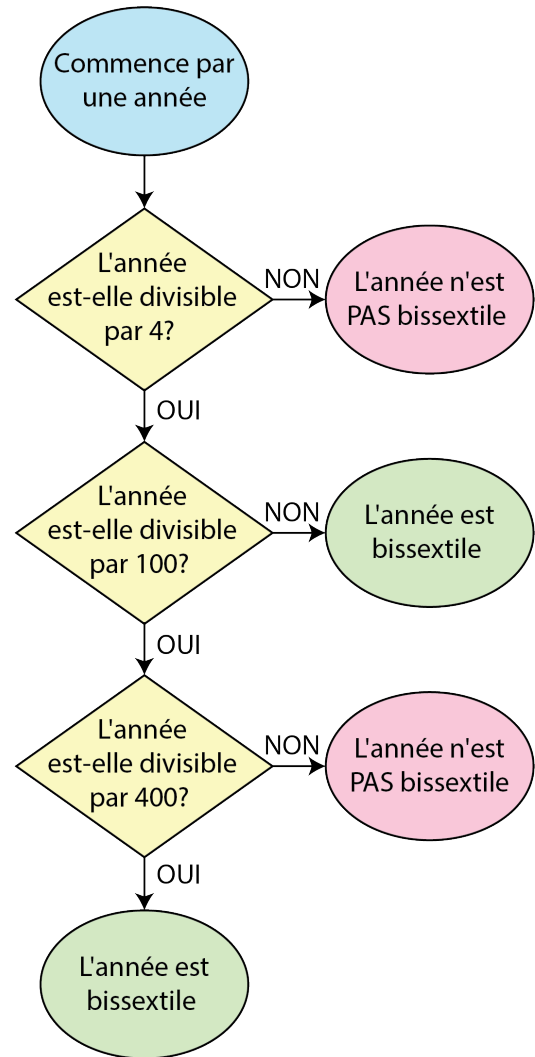



Problem of the Week

Problem D and Solution

A Big Leap

Problem

Most people think of a year as 365 days, however it is actually slightly more than 365 days. To account for this extra time we use leap years, which are years containing one extra day.

Mara uses the flowchart shown to determine whether or not a given year is a leap year. She has concluded the following:

- 2018 was **not** a leap year because 2018 is not divisible by 4.
- 2016 was a leap year because 2016 is divisible by 4, but not 100.
- 2100 will **not** be a leap year because 2100 is divisible by 4 and 100, but not 400.
- 2000 was a leap year because 2000 is divisible by 4, 100, and 400.

If Mara chooses a year greater than 2000 at random, what is the probability that she chooses a leap year?

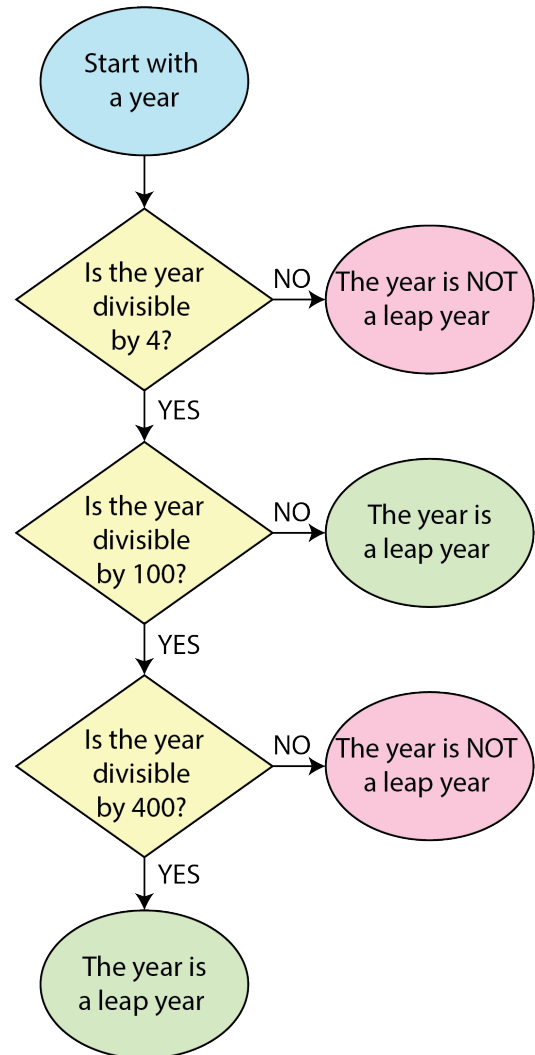



Solution

The probability of an event occurring is calculated as the number of favourable outcomes (that is, the number of outcomes where the event occurs) divided by the total number of possible outcomes. This is an issue in our problem because the number of years greater than 2000 is infinite. However, the cycle of leap years repeats every 400 years. For example, since 2044 is a leap year, so is 2444.

Thus, to determine the probability, we need to count the number of leap years in a 400-year cycle. From the flowchart we can determine that leap years are either

- multiples of 4 that are not also multiples of 100, or
- multiples of 4, 100, and 400.

Note that we can simplify the second case to just multiples of 400, since any multiple of 400 will also be a multiple of 4 and 100.

The number of multiples of 4 in a 400-year cycle is $\frac{400}{4} = 100$. However, we have included the multiples of 100, so we need to subtract these multiples. There are $\frac{400}{100} = 4$ multiples of 100 in a 400-year cycle. Thus, there are $100 - 4 = 96$ multiples of 4 that are not multiples of 100. We now need to add back the the multiples of 400. There is $\frac{400}{400} = 1$ multiple of 400 in a 400-year cycle. Thus, there are $96 + 1 = 97$ numbers that are multiples of 4 and are not multiples of 100, or that are multiples of 400.

Therefore, for every 400-year cycle, 97 of these years will be a leap year.

Therefore, the probability of Mara choosing a leap year is $\frac{97}{400} = 0.2425$.



Problème de la semaine

Problème D

Période de taille

À la fin de chaque saison de croissance, Joy aime tailler son arbre préféré afin d'en retirer les feuilles mortes. Pour ce faire, elle coupe les branches de l'arbre. Dans l'arbre, il y a 15 feuilles mortes qu'elle aimerait enlever. Joy estime le temps nécessaire, en minutes, pour couper chacune des branches de l'arbre. Ces estimations sont indiquées pour chaque branche dans la figure ci-dessous.

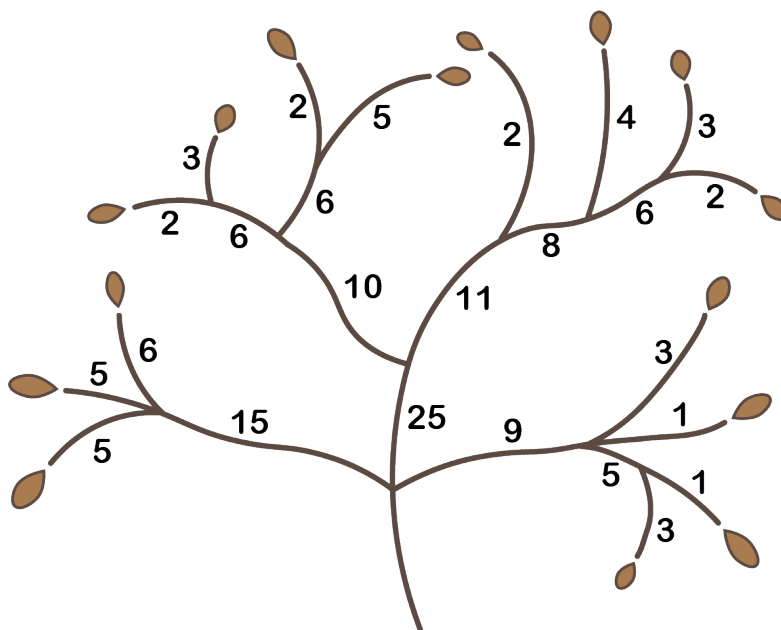

Lorsqu'une branche est coupée, toutes les branches et les feuilles qui y sont attachées sont retirées de l'arbre. Par exemple, si l'on coupe la branche dont la coupe prendrait 15 minutes, les trois feuilles les plus à gauche seront retirées.

Quel est le minimum de temps nécessaire pour que Joy puisse retirer toutes les 15 feuilles mortes ?





Problem of the Week

Problem D and Solution

Annual Pruning

Problem

At the end of each growing season, Joy likes to prune dead leaves from her favourite tree. She does this by cutting branches. For this tree, shown below, there are 15 leaves she wants to remove. She decides to give an approximate time it will take to cut each branch. These times are shown for each branch.

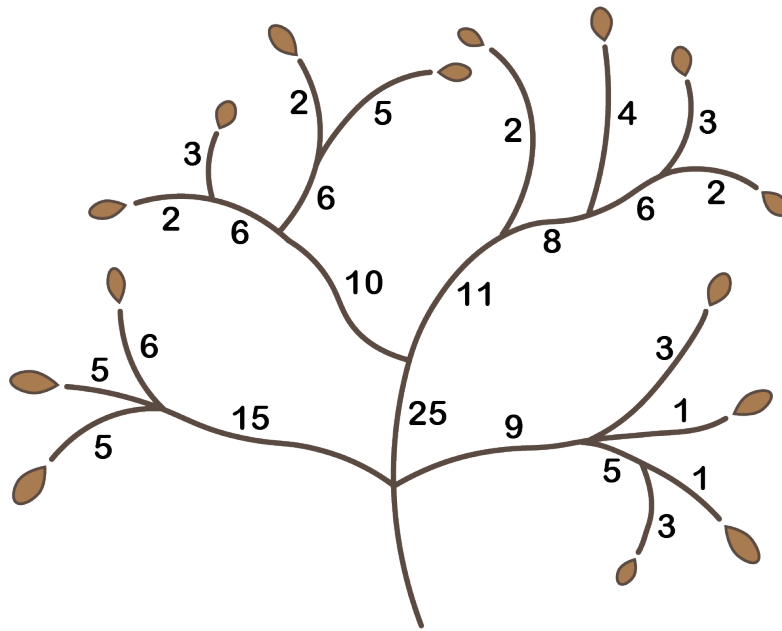

When a branch is cut, all branches and leaves attached to it are removed from the tree. For example, if you cut the branch labelled with 15, the three leftmost leaves will be removed.

What is the shortest amount of time in which Joy can remove all 15 leaves?

Solution

We label the leaves A through O in the diagram. Notice that the three leftmost leaves (A , B , and C) do not share any branches with the rest of the leaves (D through O). Therefore, removing these leaves will have no impact on removing the rest. The same is true for the eight centre leaves (D through K) and the four rightmost leaves (L , M , N , and O). This means that the shortest amount of time needed to remove all 15 leaves is the sum of the shortest amount of time needed to remove the leftmost leaves, the centre leaves, and the rightmost leaves.

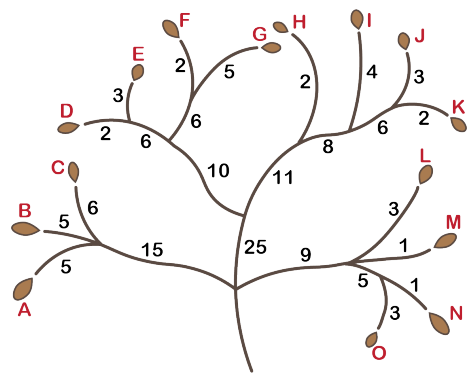

To remove the leftmost leaves we have two options: remove them all at once (which takes 15 minutes), or remove them individually (which takes $5 + 5 + 6 = 16$ minutes). The shortest amount of time needed to remove the leftmost leaves is thus 15 minutes.



To remove the rightmost leaves we have three options: remove them all at once (which takes 9 minutes), remove them individually (which takes $1 + 3 + 1 + 3 = 8$ minutes), or remove N and O together and L and M individually (which takes $5 + 1 + 3 = 9$ minutes). The shortest amount of time needed to remove the rightmost leaves is thus 8 minutes.

To remove the centre leaves we notice that if we remove them all at once it will take 25 minutes, and if remove them in two groups (leaves D, E, F, G on the left centre branch and then leaves H, I, J, K on the right centre branch) the time to do so is $10 + 11 = 21$ minutes. Since 21 minutes is less than 25 minutes, to find the least amount of time we can look at first minimizing the time to remove the leaves on the left centre branch and then minimizing the time to remove the leaves on the right centre branch.

To remove the leaves on the left centre branch we have five options: remove all the leaves together (which takes 10 minutes); remove them individually (which takes $2 + 3 + 2 + 5 = 12$ minutes); remove D and E together and F and G together (which takes $6 + 6 = 12$ minutes); remove D and E together and F and G individually (which takes $6 + 2 + 5 = 13$ minutes); or remove D and E individually and F and G together (which takes $2 + 3 + 6 = 11$ minutes). This means the least amount of time to remove the leaves on the left centre branch is 10 minutes.

To remove the leaves on the right centre branch we have four options: remove all the leaves together (which takes 11 minutes); remove them individually (which takes $2 + 4 + 3 + 2 = 11$ minutes); remove H individually and remove $I, J,$ and K together (which takes $2 + 8 = 10$ minutes); or remove H and I individually and remove J and K together (which takes $2 + 4 + 6 = 12$ minutes). This means the least amount of time to remove the leaves on the right centre branch is 10 minutes. This further means the least amount of time to remove the centre leaves is $10 + 10 = 20$ minutes.

Therefore, the least amount of time to remove all 15 leaves is $15 + 8 + 20 = 43$ minutes. Joy can achieve this time when she cuts the branches that are shown below as dashed.

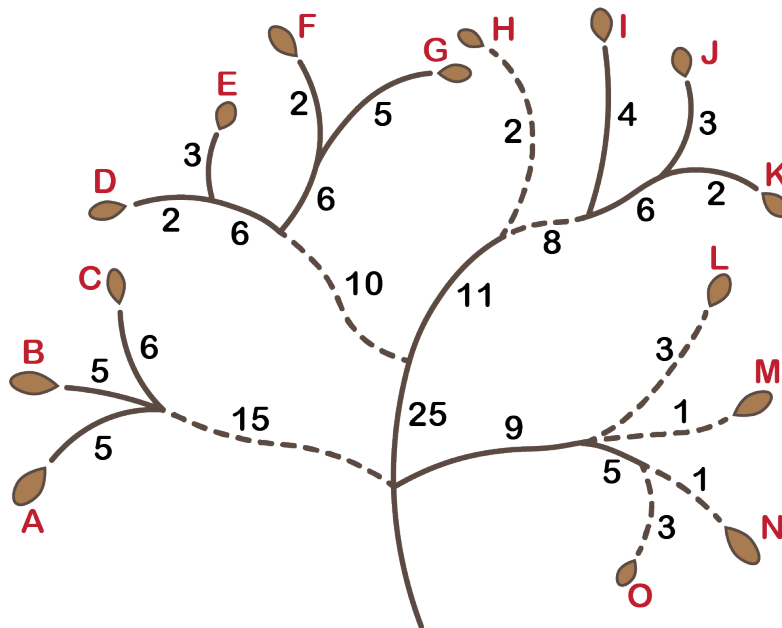



Problème de la semaine

Problème D

À vos sièges 2

Douze personnes sont assises à intervalles réguliers autour d'une table ronde, chacune tenant une carte sur laquelle figure un nombre entier différent. Pour toute paire de personnes assises côte à côte, la différence positive entre les entiers figurant sur leurs cartes est inférieure ou égale à 2. Les personnes dont les entiers sont 3, 4, et 8 sont assises comme dans la figure ci-dessous. La personne assise en face de celle qui tient 8 tient l'entier x . Quelles sont les valeurs possibles de x ?

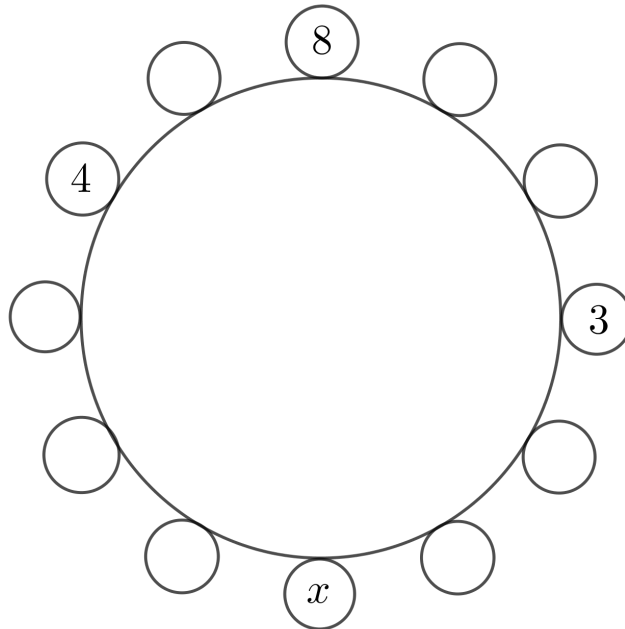



Problem of the Week

Problem D and Solution

Take a Seat 2

Problem

Twelve people are seated, equally spaced, around a circular table. They each hold a card with different integer on it. For any two people sitting beside each other, the positive difference between the integers on their cards is no more than 2. The people holding the integers 3, 4, and 8 are seated as shown. The person opposite the person holding 8 is holding the integer x . What are the possible values of x ?

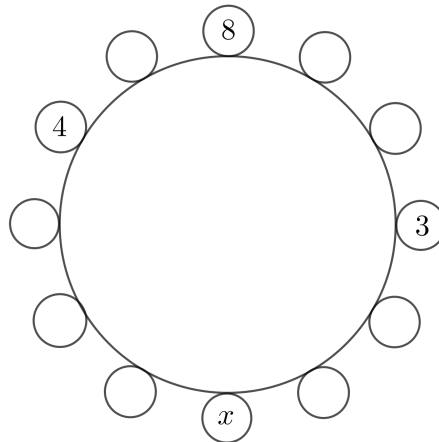

Solution

Let a represent the integer on the card between the card numbered 4 and the card numbered 8, and let b and c represent the integers on the cards between the card numbered 8 and the card numbered 3, as shown in the diagram.

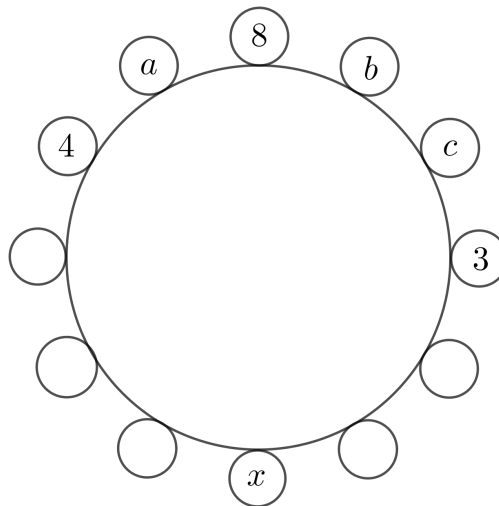

The integer 6 is the only integer that is within 2 of both 4 and 8. Therefore, $a = 6$. Now, b can be either 7, 9, or 10. (We cannot have $b = 6$ since each person has a card with a different integer on it.) If $b = 9$ or $b = 10$, then for c there is no integer that is within 2 of b and 3. Therefore, $b = 7$. Furthermore, the integer 5 is the only integer that is within 2 of both 3 and 7. Therefore, $c = 5$.

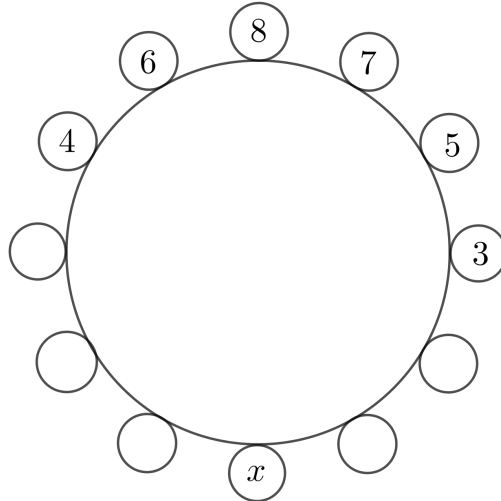

Next, we again consider the card numbered 4. The possible card numbers for its neighbours are 2, 3, 5, and 6. It is already beside the card numbered 6, and the integers 3 and 5 are on cards that are not beside the card numbered 4. Therefore, the card on the other side of the card numbered 4 must be numbered 2.

Next, we again consider the card numbered 3. The possible card numbers for its neighbours are 1, 2, 4, and 5. It is already beside the card numbered 5, and the integers 2 and 4 are on cards that are not beside the card numbered 3. Therefore, the card on the other side of the card numbered 3 must be numbered 1.

We continue in this way to determine that the other card beside the card numbered 2 must be numbered 0. Then, the other card beside the card numbered 1 must be numbered -1 . Then, the other card beside the card numbered 0 must be numbered -2 .

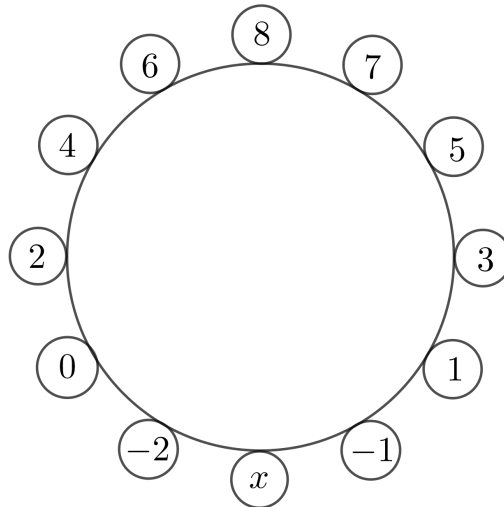

Finally, the possible card numbers for the neighbours of the card numbered -2 are 0, -1 , -3 , and -4 . Also, the possible card numbers for the neighbours of the card numbered -1 are 1, 0, -2 , and -3 . Thus, since x is a neighbour of both the card numbered -2 and the card numbered -1 , we must have $x = 0$ or $x = -3$. Since 0 is already on another card, then $x = -3$.

Gestion des données (D)

**Amène-moi à la
couverture**



Problème de la semaine

Problème D

Fléchette fortune

Kurtis conçoit un jeu pour une foire mathématique. Kurtis fixe n cercles, chacun ayant un rayon de 1 mètre, sur un mur carré de côté n mètres, n étant un entier strictement positif, en s'assurant qu'ils ne se chevauchent pas. Les personnes qui participent lanceront une fléchette vers le mur et remporteront un prix si la fléchette atterrit sur l'un des cercles. Kurtis souhaite que la probabilité de gagner soit au moins égale à $\frac{1}{2}$.

Si l'on suppose que chaque fléchette atteint le mur en un point unique et aléatoire, quelle est la plus grande valeur possible de n ?

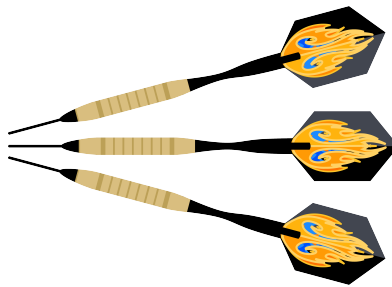



Problem of the Week

Problem D and Solution

Throw to Win

Problem

Kurtis is creating a game for a math fair. They attach n circles, each with radius 1 metre, onto a square wall with side length n metres, where n is a positive integer, so that none of the circles overlap. Participants will throw a dart at the wall and if the dart lands on a circle, they win a prize. Kurtis wants the probability of winning the game to be at least $\frac{1}{2}$.

If they assume that each dart hits the wall at a single random point, then what is the largest possible value of n ?

Solution

The area of the square wall with side length n metres is n^2 square metres.

The area of each circle is $\pi(1)^2 = \pi$ square metres. Since there are n circles, the total area covered by circles is $n\pi$ square metres.

If each dart hits the wall at a single random point, then the probability that a dart lands on a circle is equal to the area of the wall covered by circles divided by the total area of the wall. That is,

$$\frac{n\pi \text{ square metres}}{n^2 \text{ square metres}} = \frac{\pi}{n}$$

If this probability must be at least $\frac{1}{2}$, then

$$\begin{aligned}\frac{\pi}{n} &\geq \frac{1}{2} \\ \pi &\geq \frac{n}{2}, \quad \text{since } n > 0 \\ 2\pi &\geq n \\ n &\leq 2\pi \approx 6.28\end{aligned}$$

Thus, since n is an integer, the largest possible value of n is 6.



Géométrie et mesure (G)

Amène-moi à la
couverture



Problème de la semaine

Problème D

Carrément imbriqué

Dans le carré $PQRS$, W est situé sur PQ , U est situé sur QR , T est situé sur PS et V est situé sur TU de manière que $QUVW$ soit un carré et que $PWVT$ et $RSTU$ soient des rectangles.

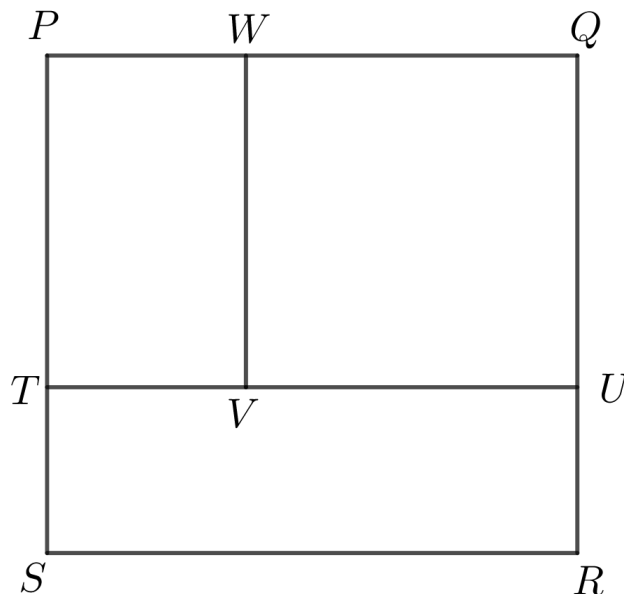

Le carré $PQRS$ a des côtés de longueur 9 cm et

$$\text{l'aire de } QUVW - \text{l'aire de } RSTU = \text{l'aire de } RSTU - \text{l'aire de } PWVT$$

Si le carré $QUVW$ a des côtés de longueur x cm, détermine la valeur de x ainsi que les aires des rectangles $PWVT$ et $RSTU$.



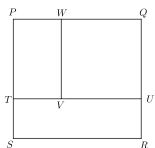

Problem of the Week

Problem D and Solution

Square Parts

Problem

Square $PQRS$ has W on PQ , U on QR , T on PS , and V on TU such that $QUVW$ is a square, and $PWVT$ and $RSTU$ are rectangles.

The side length of square $PQRS$ is 9 cm, and

$$\text{area of } QUVW - \text{area of } RSTU = \text{area of } RSTU - \text{area of } PWVT$$

If square $QUVW$ has side length equal to x cm, determine the value of x and the areas of rectangles $PWVT$ and $RSTU$.

Solution

We know $SR = PQ = 9$ cm and $WQ = QU = x$ cm.

Therefore, $PW = PQ - WQ = (9 - x)$ cm. Similarly, $UR = (9 - x)$ cm.

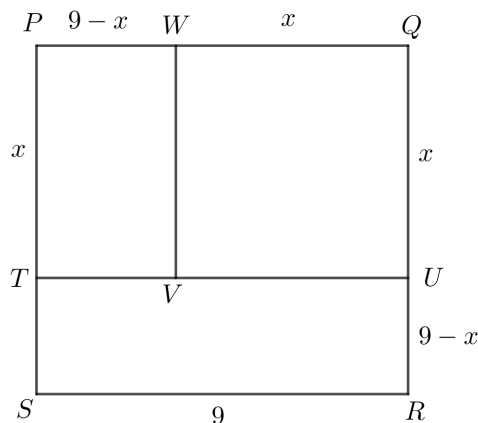

Thus, we have that the area of $QUVW$ is equal to x^2 cm², the area of $RSTU$ is equal to $9(9 - x)$ cm², and the area of $PWVT$ is equal to $x(9 - x)$ cm².

Therefore, we know that

$$\begin{aligned} \text{area of } QUVW - \text{area of } RSTU &= \text{area of } RSTU - \text{area of } PWVT \\ x^2 - 9(9 - x) &= 9(9 - x) - x(9 - x) \\ x^2 - 81 + 9x &= 81 - 9x - 9x + x^2 \\ 27x &= 162 \\ x &= 6 \end{aligned}$$

Therefore, $x = 6$ cm, the area of $PWVT$ is equal to $x(9 - x) = 6(9 - 6) = 18$ cm², and the area of $RSTU = 9(9 - x) = 9(9 - 6) = 27$ cm².



Problème de la semaine

Problème D

En quête de l'angle x

Un cercle de centre C a un diamètre PQ et un rayon CS . La corde PR coupe le rayon CS et la corde SQ , respectivement en A et en B . Si $\angle CAP = 90^\circ$, $\angle RPQ = 24^\circ$ et $\angle QBR = x^\circ$, détermine la valeur de x .

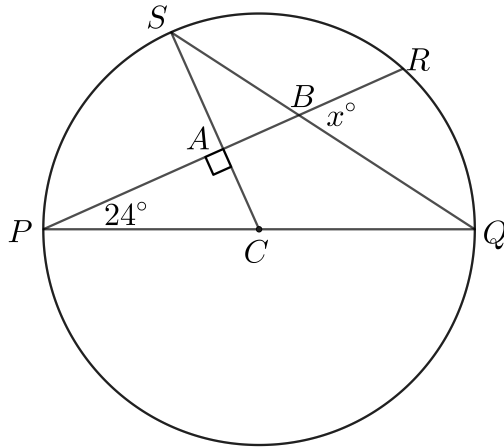



Problem of the Week

Problem D and Solution

Find that Angle

Problem

A circle with centre C has a diameter PQ and radius CS . Chord PR intersects CS and chord SQ at A and B , respectively. If $\angle CAP = 90^\circ$, $\angle RPQ = 24^\circ$, and $\angle QBR = x^\circ$, then determine the value of x .

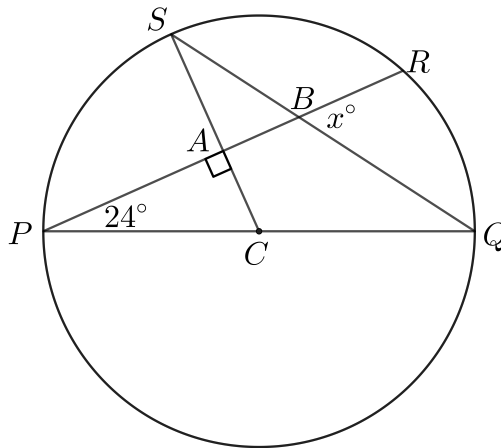

Solution

Solution 1

Since the angles in a triangle sum to 180° , in $\triangle CAP$, $\angle ACP = 180^\circ - 90^\circ - 24^\circ = 66^\circ$.

Since PQ is a diameter, PCQ is therefore a straight line. Thus, $\angle ACP + \angle QCS = 180^\circ$, and so $\angle QCS = 180^\circ - \angle ACP = 180^\circ - 66^\circ = 114^\circ$.

Since CS and CQ are radii of the circle, we have $CS = CQ$. It follows that $\triangle CSQ$ is isosceles and $\angle CQS = \angle CSQ$. Since the angles in a triangle sum to 180° , we have $\angle CSQ + \angle CQS + \angle QCS = 180^\circ$, and since $\angle CQS = \angle CSQ$, this gives

$$2\angle CSQ + 114^\circ = 180^\circ$$

$$2\angle CSQ = 66^\circ$$

$$\angle CSQ = 33^\circ$$

Opposite angles are equal, so it follows that $\angle SBA = \angle QBR = x^\circ$ and $\angle SAB = \angle CAP = 90^\circ$.

In $\triangle ABS$, $\angle SBA + \angle SAB + \angle ASB = 180^\circ$. Since $\angle ASB = \angle CSQ = 33^\circ$, we have

$$x^\circ + 90^\circ + 33^\circ = 180^\circ$$

$$x + 123 = 180$$

$$x = 57$$

Therefore, $x = 57$.



Solution 2

This solution will use the *exterior angle theorem*. In a triangle, the angle formed at a vertex between one side of the triangle and the extension of the other side of the triangle is called an exterior angle.

The exterior angle theorem states that the measure of an exterior angle of a triangle is equal to the sum of the two opposite interior angles.

For example, in the diagram shown, $\angle XZW$ is exterior to $\triangle XYZ$. The exterior angle theorem states that $r^\circ = p^\circ + q^\circ$.

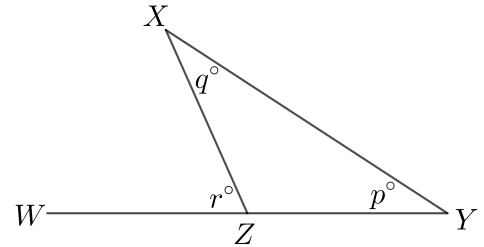

Since the angles in a triangle sum to 180° , in $\triangle CAP$, $\angle ACP = 180^\circ - 90^\circ - 24^\circ = 66^\circ$.

Since CS and CQ are radii of the circle, we have $CS = CQ$. It follows that $\triangle CSQ$ is isosceles and $\angle CQS = \angle CSQ$. Since $\angle ACP$ is exterior to $\triangle CSQ$, by the exterior angle theorem,

$$\begin{aligned} \angle ACP &= \angle CQS + \angle CSQ \\ 66^\circ &= 2\angle CQS \\ \angle CSQ &= 33^\circ \end{aligned}$$

Since $\angle QBR$ is exterior to $\triangle BQP$, by the exterior angle theorem, $\angle QBR = \angle BPQ + \angle BQP$. Since $\angle QBR = x^\circ$, $\angle BPQ = \angle RPQ$ (same angle), and $\angle BQP = \angle CQS$ (same angle), this gives

$$\begin{aligned} x^\circ &= \angle RPQ + \angle CQS \\ x &= 24 + 33 \\ x &= 57 \end{aligned}$$

Therefore, $x = 57$.

Solution 3

This solution uses the *exterior angle theorem* from Solution 2, as well as the *angle subtended by an arc theorem*. This theorem states that the measure of the angle subtended by an arc at the centre is equal to two times the measure of the angle subtended by the same arc at any point on the remaining part of the circle.

Since $\angle SCP$ is the angle at the centre subtended by arc SP , and $\angle SQP$ is an angle subtended by that same arc but on the circle, we know that $\angle SCP = 2\angle SQP$.

Since the angles in a triangle sum to 180° , in $\triangle CAP$, $\angle ACP = 180^\circ - 90^\circ - 24^\circ = 66^\circ$. Thus, since $\angle SCP = \angle ACP$ (same angle), we have $\angle SCP = \angle ACP = 66^\circ$. Therefore, $\angle SCP = 2\angle SQP$ gives $66^\circ = 2\angle SQP$, and thus $\angle SQP = 33^\circ$.

Since $\angle QBR$ is exterior to $\triangle BQP$, by the exterior angle theorem, $\angle QBR = \angle BPQ + \angle BQP$. Since $\angle QBR = x^\circ$, $\angle BPQ = \angle RPQ$ (same angle), and $\angle BQP = \angle SQP$ (same angle), this gives

$$\begin{aligned} x^\circ &= \angle RPQ + \angle SQP \\ x &= 24 + 33 \\ x &= 57 \end{aligned}$$

Therefore, $x = 57$.



Problème de la semaine

Problème D

Où est Pierre ?

Amir, Bita, Colin et Delilah se tiennent aux quatre coins d'un terrain rectangulaire, Amir et Colin étant à des coins opposés. Pierre, quant à lui, se trouve à l'intérieur du terrain, à 5 m d'Amir, 11 m de Bita et 10 m de Delilah. Dans la figure, les emplacements d'Amir, de Bita, de Colin, de Delilah et de Pierre sont respectivement représentés par les lettres A , B , C , D et P .

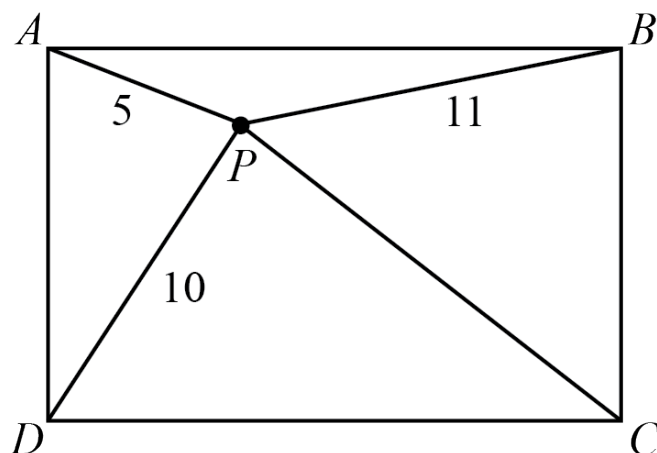

Détermine la distance entre Pierre et Colin.

ASTUCE: Pense à dessiner un segment de droite passant par P et perpendiculaire à deux des côtés du rectangle, puis à utiliser le théorème de Pythagore.



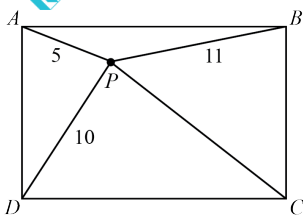

Problem of the Week

Problem D and Solution

Where is Pete?

Problem

Amir, Bita, Colin, and Delilah are standing on the four corners of a rectangular field, with Amir and Colin at opposite corners. Pete is standing inside the field 5 m from Amir, 11 m from Bita, and 10 m from Delilah. In the diagram, the locations of Amir, Bita, Colin, Delilah, and Pete are marked with A , B , C , D , and P , respectively. Determine the distance from Pete to Colin.

Solution

We start by drawing a line through P , perpendicular to AB and DC . Let Q be the point of intersection of the perpendicular with AB and R be the point of intersection with DC .

Since QP is perpendicular to AB , $\angle AQP = 90^\circ$ and $\angle BQP = 90^\circ$. Since PR is perpendicular to DC , $\angle DRP = 90^\circ$ and $\angle CRP = 90^\circ$. We also have that $AQ = DR$ and $BQ = CR$.

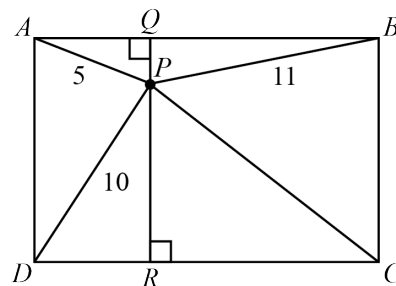

We can apply the Pythagorean Theorem in $\triangle AQP$ and $\triangle BQP$.

From $\triangle AQP$, we have $AQ^2 + QP^2 = AP^2 = 5^2 = 25$. Rearranging, we have

$$QP^2 = 25 - AQ^2 \quad (1)$$

From $\triangle BQP$, we have $BQ^2 + QP^2 = BP^2 = 11^2 = 121$. Rearranging, we have

$$QP^2 = 121 - BQ^2 \quad (2)$$

Since $QP^2 = QP^2$, from (1) and (2) we find that $25 - AQ^2 = 121 - BQ^2$ or $BQ^2 - AQ^2 = 96$. Since $AQ = DR$ and $BQ = CR$, this also tells us

$$CR^2 - DR^2 = 96 \quad (3)$$

We can now apply the Pythagorean Theorem in $\triangle DRP$ and $\triangle CRP$. From $\triangle DRP$, we have $DR^2 + RP^2 = DP^2 = 10^2 = 100$. Rearranging, we have

$$RP^2 = 100 - DR^2 \quad (4)$$

When we apply the Pythagorean Theorem to $\triangle CRP$ we have $CR^2 + RP^2 = CP^2$. Rearranging, we have

$$RP^2 = CP^2 - CR^2 \quad (5)$$

Since $RP^2 = RP^2$, from (4) and (5) we find that $100 - DR^2 = CP^2 - CR^2$, or

$$CR^2 - DR^2 = CP^2 - 100 \quad (6)$$

From (3), we have $CR^2 - DR^2 = 96$, so (6) becomes $96 = CP^2 - 100$ or $CP^2 = 196$. Thus $CP = 14$, since $CP > 0$.

Therefore the distance from Pete to Colin is 14 m.



Problème de la semaine

Problème D

Chevauchement 2

Selena dessine le carré $ABCD$ dont les côtés mesurent 16 cm. Endre dessine ensuite le triangle AED sur le carré $ABCD$ de manière que :

- les côtés AE et DE touchent BC en F et G respectivement et
- l'aire du triangle AED est le double de l'aire du carré $ABCD$.

Détermine l'aire du trapèze $AFGD$.

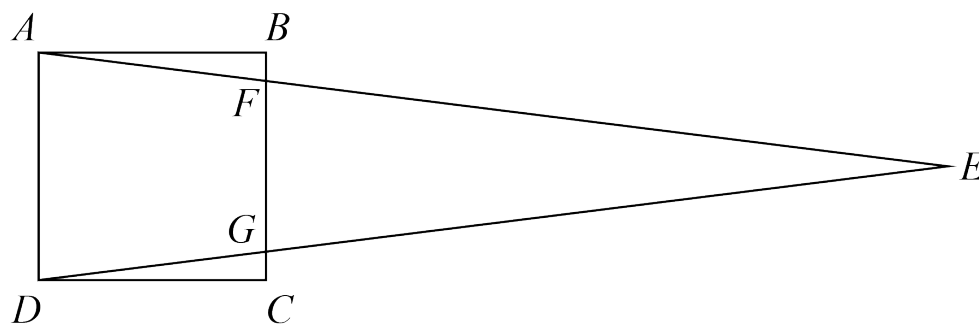

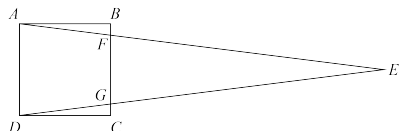

Problem of the Week

Problem D and Solution

Overlapping Shapes 2

Problem

Selena draws square $ABCD$ with side length 16 cm. Endre then draws $\triangle AED$ on top of square $ABCD$ so that

- sides AE and DE meet BC at F and G , respectively, and
- the area of $\triangle AED$ is twice the area of square $ABCD$.

Determine the area of trapezoid $AFGD$.

Solution

We construct an altitude of $\triangle AED$ from E , intersecting AD at P and BC at Q . Since $ABCD$ is a square, we know that AD is parallel to BC . Therefore, since PE is perpendicular to AD , QE is perpendicular to FG and thus an altitude of $\triangle FEG$.

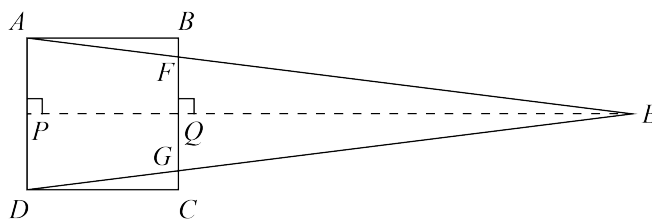

The area of square $ABCD$ is $16 \times 16 = 256 \text{ cm}^2$. Since the area of $\triangle AED$ is twice the area of square $ABCD$, it follows that the area of $\triangle AED$ is $2 \times 256 = 512 \text{ cm}^2$.

We also know that

$$\begin{aligned} \text{Area } \triangle AED &= AD \times PE \div 2 \\ 512 &= 16 \times PE \div 2 \\ 512 &= 8 \times PE \\ PE &= 512 \div 8 \\ &= 64 \text{ cm} \end{aligned}$$

Since $\angle APQ = 90^\circ$, we know that $ABQP$ is a rectangle, and so $PQ = AB = 16$ cm. We also know that $PE = PQ + QE$. Since $PE = 64$ cm and $PQ = 16$ cm, it follows that $QE = PE - PQ = 64 - 16 = 48$ cm.

From here we proceed with two different solutions.



Solution 1

We will use the relationships between the areas of the shapes to determine the length of FG .

$$\begin{aligned}\text{Area of trapezoid } AFGD + \text{Area } \triangle FEG &= \text{Area } \triangle AED \\ (AD + FG) \times AB \div 2 + FG \times QE \div 2 &= 512 \\ (16 + FG) \times 16 \div 2 + FG \times 48 \div 2 &= 512 \\ (16 + FG) \times 8 + 24 \times FG &= 512 \\ 128 + 8FG + 24FG &= 512 \\ 32FG &= 384 \\ FG &= 12 \text{ cm}\end{aligned}$$

Now we can use FG to calculate the area of trapezoid $AFGD$.

$$\begin{aligned}\text{Area of trapezoid } AFGD &= (AD + FG) \times AB \div 2 \\ &= (16 + 12) \times 16 \div 2 \\ &= 28 \times 8 = 224 \text{ cm}^2\end{aligned}$$

Therefore, the area of trapezoid $AFGD$ is 224 cm^2 .

Solution 2

We will use similar triangles to determine the length of FG . We know that $\angle AED = \angle FEG$. Also, since AD is parallel to FG it follows that $\angle EAD$ and $\angle EFG$ are corresponding angles, so are equal. Thus, by angle-angle similarity, $\triangle AED \sim \triangle FEG$. Therefore,

$$\begin{aligned}\frac{AD}{PE} &= \frac{FG}{QE} \\ \frac{16}{64} &= \frac{FG}{48} \\ \frac{1}{4} &= \frac{FG}{48} \\ FG &= 48 \times \frac{1}{4} = 12 \text{ cm}\end{aligned}$$

Now we can use FG to calculate the area of trapezoid $AFGD$.

$$\begin{aligned}\text{Area of trapezoid } AFGD &= (AD + FG) \times AB \div 2 \\ &= (16 + 12) \times 16 \div 2 \\ &= 28 \times 8 = 224 \text{ cm}^2\end{aligned}$$

Therefore, the area of trapezoid $AFGD$ is 224 cm^2 .

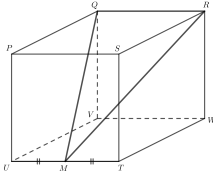

Problem of the Week

Problem D and Solution

Halfway to the Other Side

Problem

Cube $PQRSTU VW$ has side length 2. Point M is the midpoint of edge UT . Determine the area of $\triangle MQR$.

Solution

We first draw RT .

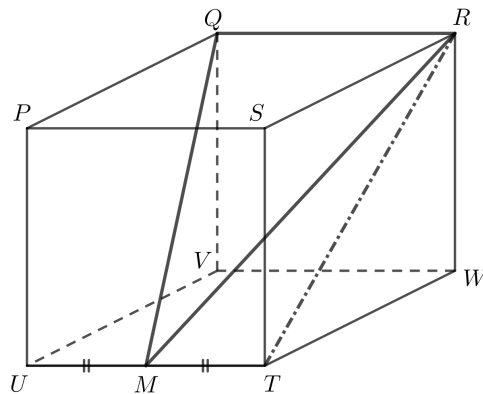

In $\triangle RWT$, $\angle RWT = 90^\circ$ and $RW = WT = 2$.

By the Pythagorean Theorem in $\triangle RWT$, $RT^2 = RW^2 + WT^2 = 2^2 + 2^2 = 8$.

Therefore, $RT = \sqrt{8}$, since $RT > 0$.

$\triangle MQR$ has base equal to the length of QR , which is 2.

Notice that the height of $\triangle MQR$ is equal to the distance from side QR of the cube to side UT of the cube, which is equal to the length of RT or $\sqrt{8}$.

Therefore, area of $\triangle MQR = \frac{\text{base} \times \text{height}}{2} = \frac{2 \times \sqrt{8}}{2} = \sqrt{8}$ units squared.



Problème de la semaine

Problème D

Carrés de Pi

Le jour de Pi est une célébration annuelle de la constante mathématique π . Le jour de Pi est célébré le 14 mars, car 3, 1 et 4 sont les trois premiers chiffres significatifs de π .

Archimède a déterminé des bornes inférieures pour π en trouvant les périmètres des polygones réguliers inscrits dans un cercle de diamètre 1. (Les sommets d'un polygone inscrit dans un cercle sont tous situés sur le cercle.) Il a également déterminé des bornes supérieures pour π en trouvant les périmètres des polygones réguliers circonscrits à un cercle de diamètre 1. (Un polygone circonscriptible est un polygone possédant un cercle inscrit, soit un cercle tangent à tous ces côtés. Autrement dit, chaque côté du polygone touche le cercle en un point.)

Dans ce problème, on va déterminer une borne inférieure pour π et une borne supérieure pour π en considérant un carré inscrit dans un cercle de diamètre 1 et un carré circonscrit à un cercle de diamètre 1.

Considérons un cercle de centre C et de diamètre 1. Puisque le cercle a un diamètre de 1, sa circonférence est égale à π . Considérons maintenant le carré inscrit $ABDE$ et le carré circonscrit $FGHJ$.

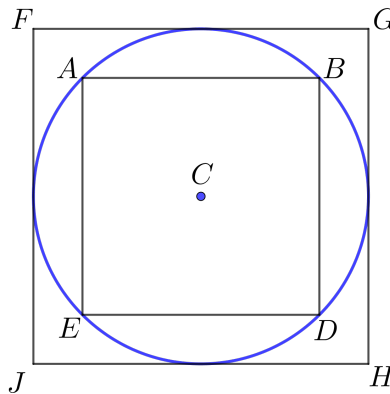

Le périmètre du carré $ABDE$ est inférieur à la circonférence du cercle, π , ce qui nous permet d'obtenir une borne inférieure pour la valeur de π . Le périmètre du carré $FGHJ$ est supérieur à la circonférence du cercle, π , ce qui nous permet d'obtenir une borne supérieure pour la valeur de π .

En utilisant ces carrés, détermine une borne inférieure et une borne supérieure pour π .

NOTE: Pour ce problème, les renseignements suivants peuvent s'avérer utiles:

1. Pour un cercle de centre C , les diagonales d'un carré inscrit se coupent à angle droit en C .
2. Pour un cercle de centre C , les diagonales d'un carré circonscrit se coupent à angle droit en C .
3. Si une droite est tangente à un cercle, alors cette droite est perpendiculaire au rayon qui relie le centre du cercle et le point de tangence.

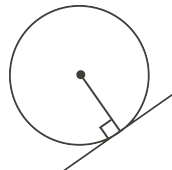



Problem of the Week

Problem D and Solution

Pi Squares

Problem

Pi Day is an annual celebration of the mathematical constant π . Pi Day is observed on March 14, since 3, 1, and 4 are the first three significant digits of π .

Archimedes determined lower bounds for π by finding the perimeters of regular polygons inscribed in a circle with diameter of length 1. (An inscribed polygon of a circle has all of its vertices on the circle.) He also determined upper bounds for π by finding the perimeters of regular polygons circumscribed in a circle with diameter of length 1. (A circumscribed polygon of a circle has all sides tangent to the circle. That is, each side of the polygon touches the circle in one spot.)

In this problem, we will determine a lower bound for π and an upper bound for π by considering an inscribed square and a circumscribed square in a circle of diameter 1.

Consider a circle with centre C and diameter 1. Since the circle has diameter 1, it has circumference equal to π . Now consider the inscribed square $ABDE$ and the circumscribed square $FGHJ$.

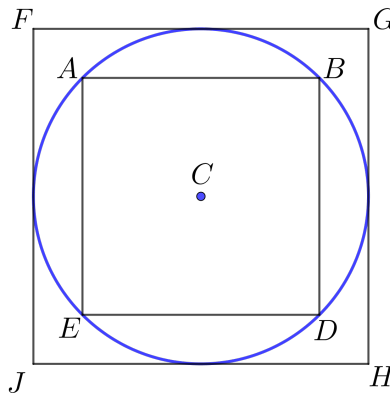

The perimeter of square $ABDE$ will be less than the circumference of the circle, π , and will thus give us a lower bound for the value of π . The perimeter of square $FGHJ$ will be greater than the circumference of the circle, π , and will thus give us an upper bound for the value of π .

Using these squares, determine a lower bound and an upper bound for π .

NOTE: For this problem, you may want to use the following known results about circles:

1. For a circle with centre C , the diagonals of an inscribed square meet at 90° at C .
2. For a circle with centre C , the diagonals of a circumscribed square meet at 90° at C .
3. If a line is tangent to a circle, then the line is perpendicular to the radius drawn to the point of tangency.

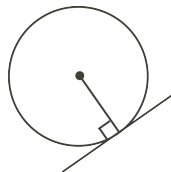



Solution

For the inscribed square $ABDE$, draw line segments AC and BC . Both AC and BC are radii of the circle with diameter 1, so $AC = BC = 0.5$.

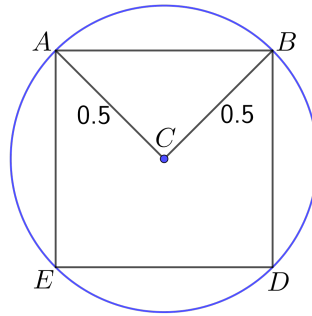

Since the diagonals of square $ABDE$ meet at 90° at C , it follows that $\triangle ACB$ is a right-angled triangle with $\angle ACB = 90^\circ$. We can use the Pythagorean Theorem to find the length of AB .

$$\begin{aligned} AB^2 &= AC^2 + BC^2 \\ &= (0.5)^2 + (0.5)^2 \\ &= 0.25 + 0.25 \\ &= 0.5 \end{aligned}$$

Therefore, $AB = \sqrt{0.5}$, since $AB > 0$.

Since AB is one of the sides of the inscribed square, the perimeter of square $ABDE$ is equal to $4 \times AB = 4\sqrt{0.5}$. This gives us a lower bound for π . That is, we know $\pi > 4\sqrt{0.5} \approx 2.828$.

For the circumscribed square, let M be the point of tangency on side FJ and let N be the point of tangency on GH . Draw radii CM and CN . Since M is a point of tangency, we know that $\angle FMC = 90^\circ$, and thus CM is parallel to FG . Similarly, CN is parallel to GH .

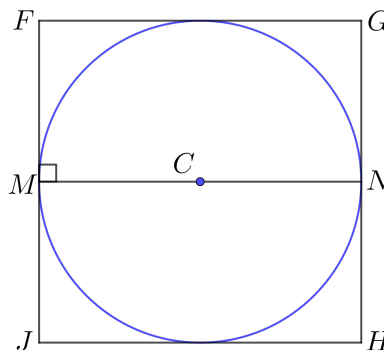

Thus, MN is a straight line segment, and since it passes through C , the centre of the circle, MN must also be a diameter of the circle. Thus, $MN = 1$. Also, $FMNG$ is a rectangle, so $FG = MN = 1$ and the perimeter of square $FGHJ$ is equal to $4 \times FG = 4(1) = 4$. This gives us an upper bound for π . That is, we know $\pi < 4$.

Therefore, a lower bound for π is $4\sqrt{0.5} \approx 2.828$ and an upper bound for π is 4. That is, $4\sqrt{0.5} < \pi < 4$.

NOTE: Since we know that $\pi \approx 3.14$, these are not the best bounds for π . Archimedes used regular polygons with more sides to get better bounds. In the Problem of the Week E problem, we investigate using regular hexagons to get better bounds.



Problème de la semaine

Problème D

Créer une éclipse

Quinnen a créé un modèle pour démontrer les éclipses. Elle a utilisé une ampoule DEL sphérique de 98 mm de diamètre pour représenter le Soleil et des sphères en mousse de 30 mm et 14 mm de diamètres pour représenter respectivement la Terre et la Lune. La Terre et le Soleil sont fixés à une base à l'aide de tiges métalliques et la Lune est reliée à la tige de la Terre par un fil métallique afin qu'elle puisse tourner autour de la Terre. Les centres de la Terre, de la Lune et du Soleil sont tous situés à la même hauteur au-dessus de la base. Quinnen fait tourner la Lune autour de la Terre et s'arrête lorsque la Lune est à son point le plus proche du Soleil. Dans cette configuration, son modèle représente une éclipse solaire totale. Autrement dit, si l'on regardait le Soleil depuis le point à la surface de la Terre le plus proche du Soleil, la Lune bloquerait complètement le Soleil. Dans cette configuration, la distance entre le centre de la Lune et le centre du Soleil est de 360 mm.

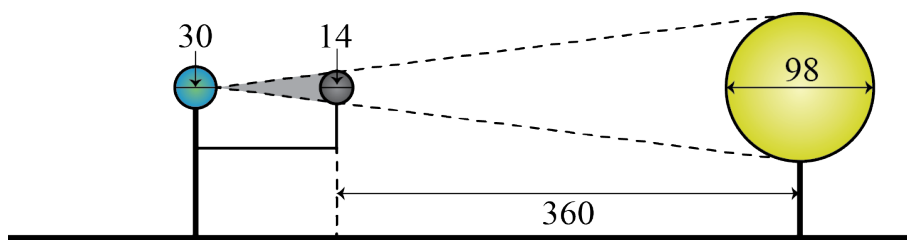

Détermine la distance maximale possible entre le centre de la Terre et le centre de la Lune dans le modèle de Quinnen.

NOTE: La propriété suivante pourrait s'avérer utile :

Toute tangente à un cercle est perpendiculaire au rayon du cercle passant par le point de contact.

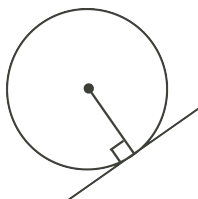



Problem of the Week

Problem D and Solution

Making an Eclipse

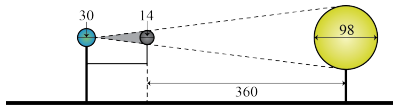

Problem

Quinnen made a model to demonstrate eclipses. She used a spherical LED bulb with diameter 98 mm to represent the Sun, and foam spheres with diameters 30 mm and 14 mm to represent the Earth and the Moon, respectively. The Earth and Sun are attached to a base using metal rods, and the Moon is connected to the Earth's rod by a wire so that it can rotate around the Earth. The centres of the Earth, Moon, and Sun are all the same distance above the base. Quinnen rotates the Moon around the Earth and stops when the Moon is at its closest point to the Sun. In this configuration, her model demonstrates a total solar eclipse. In other words, if you were able to look towards the Sun from the point on the surface of the Earth closest to the Sun, the Moon would completely block the Sun. In this configuration, the distance between centre of the Moon and the centre of the Sun is 360 mm.

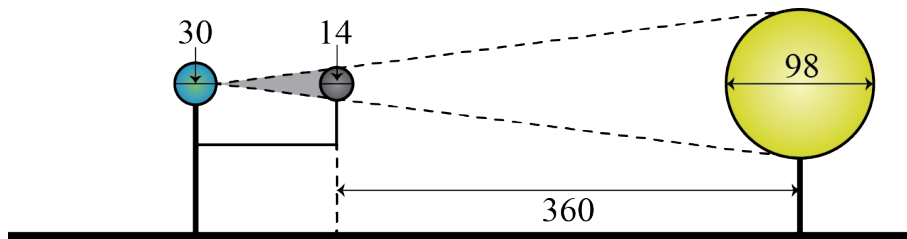

Determine the maximum possible distance between the centre of the Earth and the centre of the Moon in Quinnen's model.

NOTE: You may find the following known result about circles useful:

If a line is tangent to a circle, then the perpendicular to that line at the point of tangency passes through the centre of the circle.

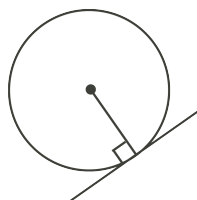

Solution

If the distance between the centre of the Earth and the centre of the Moon is at its maximum, then the area on the surface of the Earth that experiences the total solar eclipse must be as small as possible. Thus, we will assume a singular point on the Earth's surface experiences a total solar eclipse. We will call this point A .

We represent the Earth, Moon, and Sun as circles with centres E , M , and S , respectively. Since the centres of the Earth, Moon, and Sun are all the same



distance above the base, E , M , and S all lie on a line. Then A is the point on the circle with centre E that is closest to M , and lies on the line through E , M , and S .

We draw a line from A tangent to both the circle with centre M and the circle with centre S . This line meets the circle with centre M at point B , and the circle with centre S at point C . It follows that BM is a radius of the circle with centre M , so $BM = 14 \div 2 = 7$ mm. Similarly, CS is a radius of the circle with centre S , so $CS = 98 \div 2 = 49$ mm.

Using the given circle result, $\angle ABM = 90^\circ$ and $\angle ACS = 90^\circ$. Since $\angle BAM = \angle CAS$, (same angle), it follows that $\triangle ABM \sim \triangle ACS$.

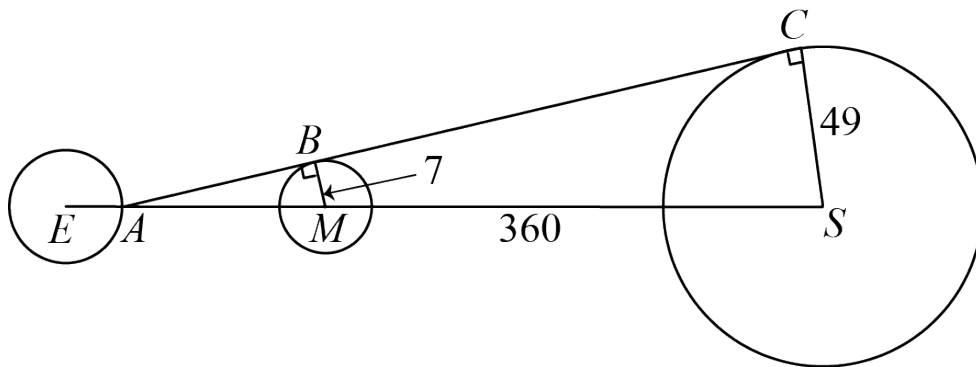

Using properties of similar triangles,

$$\begin{aligned} \frac{AM}{BM} &= \frac{AS}{CS} \\ \frac{AM}{7} &= \frac{AM + 360}{49} \\ 49(AM) &= 7(AM) + 2520 \\ 42(AM) &= 2520 \\ AM &= 60 \end{aligned}$$

Since A is on the circumference of the circle with centre E , $EA = 30 \div 2 = 15$ mm. It follows that $EM = EA + AM = 15 + 60 = 75$ mm. Therefore, the maximum possible distance between the centre of the Earth and the centre of the Moon in Quinnen's model is 75 mm.



Problème de la semaine

Problème D

Jeu de réflexions

Le triangle ABC a pour sommets $A(2, 1)$, $B(5, 8)$ et $C(1, c)$ avec $c > 0$.

Les sommets A et B subissent une réflexion par rapport à l'axe des ordonnées tandis que le sommet C subit une réflexion par rapport à l'axe des abscisses. Les trois points de l'image sont colinéaires. C'est-à-dire que les trois points sont situés sur une même droite.

Détermine les coordonnées de C .

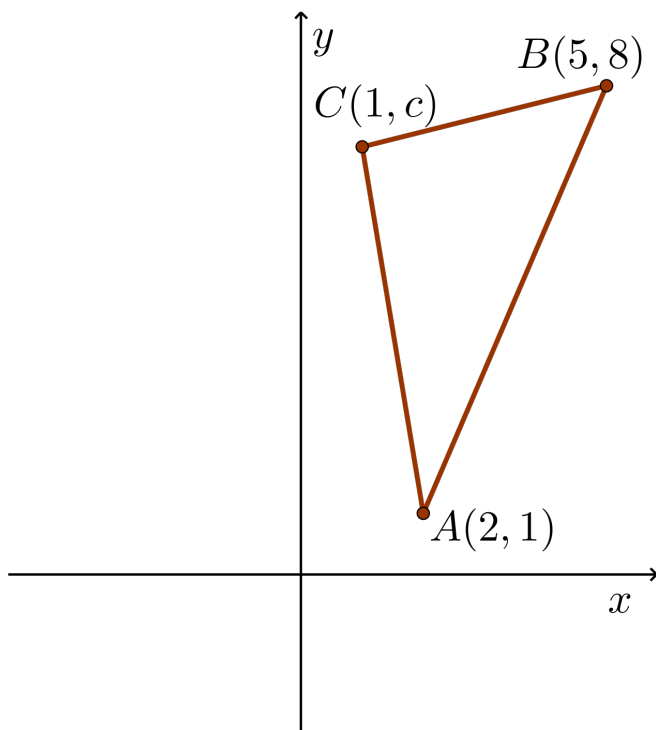



Problem of the Week

Problem D and Solution

Reflect on This

Problem

$\triangle ABC$ has vertices $A(2, 1)$, $B(5, 8)$, and $C(1, c)$, where $c > 0$.

Vertices A and B are reflected in the y -axis, and vertex C is reflected in the x -axis. The three image points are collinear. That is, a line passes through the three image points.

Determine the coordinates of C .

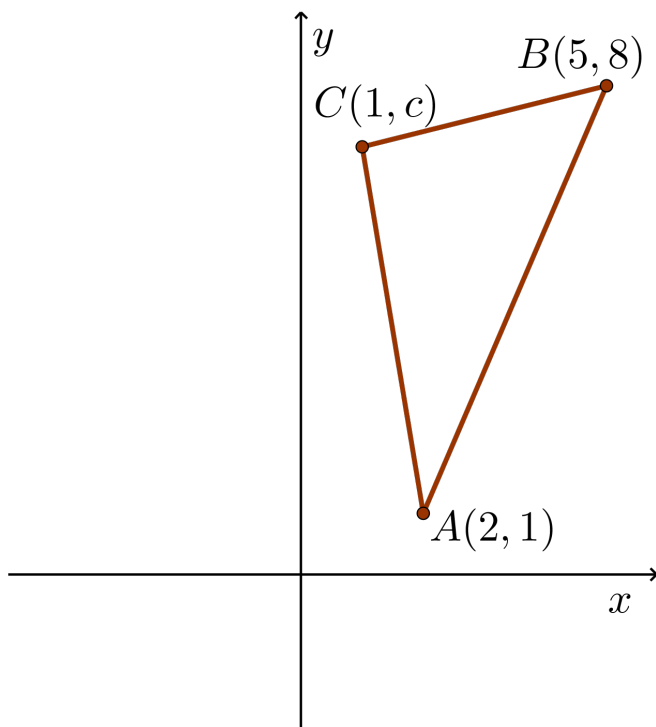

Solution

When a point is reflected in the y -axis, the image point has the same y -coordinate and the x -coordinate is -1 multiplied by the pre-image x -coordinate. Thus, the image of $A(2, 1)$ is $A'(-2, 1)$, and the image of $B(5, 8)$ is $B'(-5, 8)$.

When a point is reflected about the x -axis, the image point has the same x -coordinate and the y -coordinate is -1 multiplied by the pre-image y -coordinate. Thus, the image of $C(1, c)$ is $C'(1, -c)$.

The three image points, A' , B' , and C' , are collinear.

Solution 1

In this solution, we find the equation of the line through the three image points. We begin by first determining the slope of the line, and then the y -intercept.



$$\text{slope}(A'B') = \frac{8-1}{-5-(-2)} = -\frac{7}{3}$$

Since $A'(-2, 1)$ lies on the line, we can substitute $x = -2$, $y = 1$, and $m = -\frac{7}{3}$ into $y = mx + b$.

$$\begin{aligned} 1 &= -\frac{7}{3}(-2) + b \\ 1 &= \frac{14}{3} + b \\ b &= 1 - \frac{14}{3} \\ &= -\frac{11}{3} \end{aligned}$$

Thus, the equation of the line through the three image points is $y = -\frac{7}{3}x - \frac{11}{3}$. Since the point $C'(1, -c)$ lies on this line, we can substitute $x = 1$ and $y = -c$ into the equation to solve for c .

Thus, $-c = -\frac{7}{3}(1) - \frac{11}{3} = -\frac{18}{3} = -6$ and $c = 6$ follows.

Therefore, the coordinates of C are $(1, 6)$.

Solution 2

Since $A'(-2, 1)$, $B'(-5, 8)$, and $C'(1, -c)$ are collinear, $\text{slope}(A'B') = \text{slope}(B'C')$.

$$\begin{aligned} \text{slope}(A'B') &= \text{slope}(B'C') \\ \frac{8-1}{-5-(-2)} &= \frac{-c-8}{1-(-5)} \\ \frac{7}{-3} &= \frac{-c-8}{6} \\ 42 &= 3c+24 \\ 18 &= 3c \\ 6 &= c \end{aligned}$$

Therefore, the coordinates of C are $(1, 6)$.



Problème de la semaine

Problème D

Triangles bleus

Dans le rectangle $ABCD$, le côté AB mesure 7 m et le côté BC mesure 5 m. Quatre points, W , X , Y et Z sont situés sur la diagonale BD de manière à la diviser en cinq segments égaux. Les triangles AWX , AYZ , CWX et CYZ sont peints en bleu comme dans la figure ci-dessous.

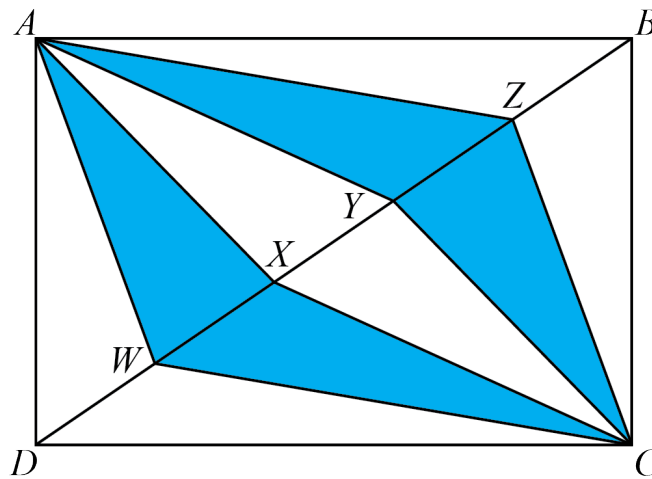

Détermine l'aire de la région peinte en bleu.



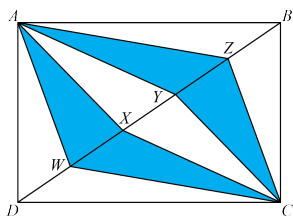

Problem of the Week

Problem D and Solution

They're Blue

Problem

In rectangle $ABCD$, the length of side AB is 7 m and the length of side BC is 5 m. Four points, W , X , Y , and Z , lie on diagonal BD , dividing it into five equal segments. Triangles AWX , AYZ , CWX , and CYZ are then painted blue, as shown. Determine the area of the painted region.

Solution

Solution 1

Using the formula for area of a triangle, $\text{area} = \frac{\text{base} \times \text{height}}{2}$, we have $\text{area } \triangle ABD = \frac{7 \times 5}{2} = \frac{35}{2} \text{ m}^2$.

The five triangles $\triangle ADW$, $\triangle AWX$, $\triangle AXY$, $\triangle AYZ$, and $\triangle ABZ$ have the same height, which is equal to the perpendicular distance between BD and A . Since

$DW = WX = XY = YZ = ZB$, it follows that the five triangles also have equal bases.

Therefore, the area of each of these five triangles is equal to $\frac{1}{5}(\text{area } \triangle ABD) = \frac{1}{5} \left(\frac{35}{2} \right) = \frac{7}{2} \text{ m}^2$.

Similarly, the area of $\triangle BCD$ is equal to $\frac{7 \times 5}{2} = \frac{35}{2} \text{ m}^2$. The five triangles

$\triangle CDW$, $\triangle CWX$, $\triangle CXY$, $\triangle CYZ$, and $\triangle CBZ$ also have the same height and equal bases.

Therefore, the area of each of these five triangles is equal to $\frac{1}{5}(\text{area } \triangle BCD) = \frac{1}{5} \left(\frac{35}{2} \right) = \frac{7}{2} \text{ m}^2$.

Therefore, the area of the painted region is $4 \left(\frac{7}{2} \right) = 14 \text{ m}^2$.

Solution 2

Since $ABCD$ is a rectangle, $\angle DAB = 90^\circ$, so $\triangle ABD$ is a right-angled triangle. We can then use the Pythagorean Theorem to calculate $BD^2 = AB^2 + AD^2 = 7^2 + 5^2 = 49 + 25 = 74$, and so $BD = \sqrt{74}$, since $BD > 0$. Therefore, $DW = WX = XY = YZ = ZB = \frac{1}{5}(BD) = \frac{1}{5}\sqrt{74}$.

Using the formula for area of a triangle, $\text{area} = \frac{\text{base} \times \text{height}}{2}$, we have $\text{area } \triangle ABD = \frac{7 \times 5}{2} = \frac{35}{2} \text{ m}^2$.

Let's treat $BD = \sqrt{74}$ as the base of $\triangle ABD$ and let h be the corresponding height. Since the area of $\triangle ABD$ is $\frac{35}{2}$, then we have $\frac{\sqrt{74} \times h}{2} = \frac{35}{2}$ and so $\sqrt{74} \times h = 35$, thus $h = \frac{35}{\sqrt{74}}$.

$\triangle AWX$ and $\triangle AYZ$ both have height $h = \frac{35}{\sqrt{74}}$ and base $\frac{\sqrt{74}}{5}$, so

$$\text{area } \triangle AWX = \text{area } \triangle AYZ = \frac{1}{2} \left(\frac{\sqrt{74}}{5} \right) \left(\frac{35}{\sqrt{74}} \right) = \frac{7}{2} \text{ m}^2.$$

Similarly, $\triangle CWX$ and $\triangle CYZ$ both have height $h = \frac{35}{\sqrt{74}}$ and base $\frac{\sqrt{74}}{5}$, so

$$\text{area } \triangle CWX = \text{area } \triangle CYZ = \frac{1}{2} \left(\frac{\sqrt{74}}{5} \right) \left(\frac{35}{\sqrt{74}} \right) = \frac{7}{2} \text{ m}^2.$$

Therefore, the area of the painted region is $4 \left(\frac{7}{2} \right) = 14 \text{ m}^2$.



Sens du nombre (N)

**Amène-moi à la
couverture**



Problème de la semaine

Problème D

Placer des tuiles 2

Hugo a une boîte de tuiles, chacune portant un nombre entier différent de 1 à 9. Chaque nombre entier figure sur au moins six tuiles. Hugo crée des nombres plus grands en plaçant les tuiles les unes à côté des autres. Par exemple, en utilisant les tuiles 3 et 7, Hugo peut créer les nombres à 2 chiffres 37 ou 73.

$$\begin{array}{|c|c|} \hline 3 & 7 \\ \hline \end{array} \quad \begin{array}{|c|c|} \hline 7 & 3 \\ \hline \end{array}$$

En utilisant six de ses tuiles, Hugo crée deux nombres à 3 chiffres dont la somme est égale à 1234. Il note ensuite la somme des six chiffres qui figurent sur les six tuiles. Combien y a-t-il de sommes différentes possibles ?

$$\begin{array}{|c|c|c|} \hline & & \\ \hline + & & \\ \hline 1 & 2 & 3 & 4 \\ \hline \end{array}$$





$$\begin{array}{r}
 \square \square \square \\
 + \square \square \square \\
 \hline
 1 \ 2 \ 3 \ 4
 \end{array}$$

Problem of the Week

Problem D and Solution

Arranging Tiles 2

Problem

Hugo has a box of tiles, each with an integer from 1 to 9 on it. Each integer appears on at least six tiles. Hugo creates larger numbers by placing tiles side by side. For example, using the tiles 3 and 7, Hugo can create the 2-digit number 37 or 73. Using six of his tiles, Hugo forms two 3-digit numbers that add to 1234. He then records the sum of the digits on the six tiles. How many different possible sums are there?

Solution

We will use the letters A , B , C , D , E , and F to represent the integers on the six chosen tiles, letting the two 3-digit numbers be ABC and DEF .

To solve this problem, we will look at each column starting with the units, then tens, and then finally the hundreds column.

$$\begin{array}{r}
 \boxed{A} \boxed{B} \boxed{C} \\
 + \boxed{D} \boxed{E} \boxed{F} \\
 \hline
 1 \ 2 \ 3 \ 4
 \end{array}$$

Since $C + F$ ends in a 4, then $C + F = 4$ or $C + F = 14$. The value of $C + F$ cannot be 20 or more, because C and F are digits. In the case that $C + F = 14$, we “carry” a 1 to the tens column. Now we will look at the tens column for these two cases.

- **Case 1:** $C + F = 4$

Since the result in the tens column is 3 and there was no “carry” from the units column, it follows that $B + E$ ends in a 3. Then $B + E = 3$ or $B + E = 13$. The value of $B + E$ cannot be 20 or more, because B and E are digits. In the case that $B + E = 13$, we “carry” a 1 to the hundreds column.

- **Case 2:** $C + F = 14$

Since the result in the tens column is 3 and there was a “carry” from the units column, it follows that $1 + B + E$ ends in a 3, so $B + E$ ends in a 2. Then $B + E = 2$ or $B + E = 12$. The value of $B + E$ cannot be 20 or more, because B and E are digits. In the case that $B + E = 12$, we “carry” a 1 to the hundreds column.

Since the result in the hundreds column is 12, then $A + D = 12$, or in the case when there was a “carry” from the tens column, $1 + A + D = 12$, so $A + D = 11$.



We summarize this information in the following tree.

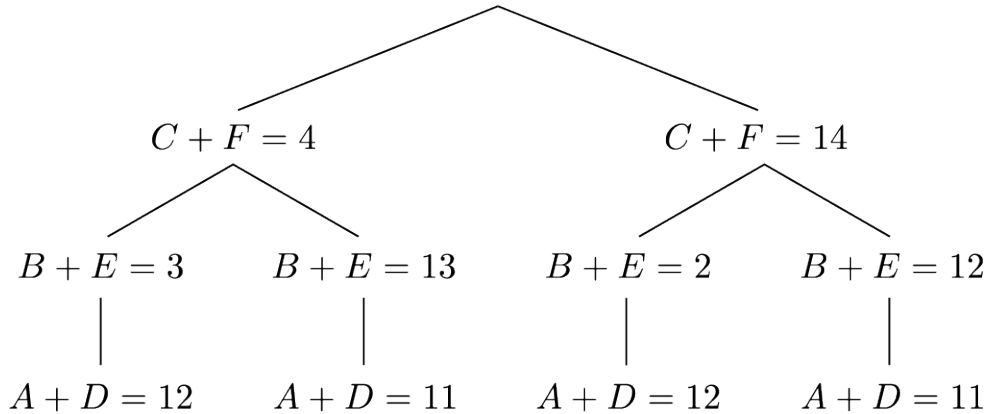

Notice that if we add the three values along each of the four branches of the tree, we obtain the sum $(C + F) + (B + E) + (A + D)$, which is equal to $A + B + C + D + E + F$.

- The first branch has the sum $4 + 3 + 12 = 19$.
- The second branch has the sum $4 + 13 + 11 = 28$.
- The third branch has the sum $14 + 2 + 12 = 28$.
- The fourth branch has the sum $14 + 12 + 11 = 37$.

Therefore, there are 3 different values for the sum of the six digits. They are 19, 28, and 37.

Indeed, we can find values for the six digits that achieve each of these sums, as shown.

sum of 19	sum of 28	sum of 37
$\begin{array}{r} \boxed{9} \boxed{2} \boxed{1} \\ + \boxed{3} \boxed{1} \boxed{3} \\ \hline 1 \ 2 \ 3 \ 4 \end{array}$	$\begin{array}{r} \boxed{7} \boxed{9} \boxed{2} \\ + \boxed{4} \boxed{4} \boxed{2} \\ \hline 1 \ 2 \ 3 \ 4 \end{array}$	$\begin{array}{r} \boxed{3} \boxed{5} \boxed{8} \\ + \boxed{8} \boxed{7} \boxed{6} \\ \hline 1 \ 2 \ 3 \ 4 \end{array}$



Problème de la semaine

Problème D

Mangues et oranges

Au supermarché de PDLs, Livio s'occupe de la mise en rayon des mangues tandis que Dhruv s'occupe de la mise en rayon des oranges. Un jour, ils ont remarqué qu'un nombre égal de mangues et d'oranges étaient pourries. De plus, $\frac{2}{3}$ des mangues étaient pourries et $\frac{3}{4}$ des oranges étaient pourries. Quelle fraction du nombre total de mangues et d'oranges était pourrie ?

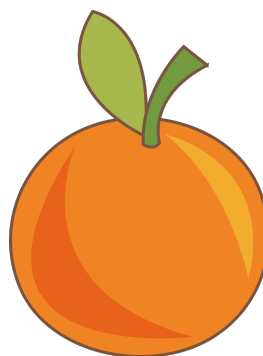
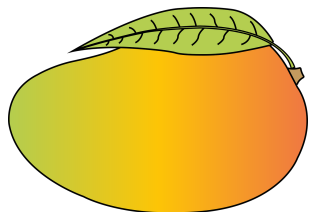

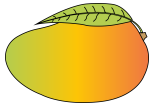

Problem of the Week

Problem D and Solution

Mangoes and Oranges



Problem

At POTW's Supermarket, Livio stocks mangoes and Dhruv stocks oranges. One day they noticed that an equal number of mangoes and oranges were rotten. Also, $\frac{2}{3}$ of the mangoes were rotten and $\frac{3}{4}$ of the oranges were rotten. What fraction of the total number of mangoes and oranges was rotten?

Solution

Solution 1:

Let the total number of mangoes be represented by a and the total number of oranges be represented by b . Since there were an equal number of rotten mangoes and rotten oranges, then $\frac{2}{3}a = \frac{3}{4}b$, so $b = \frac{4}{3}(\frac{2}{3}a) = \frac{8}{9}a$.

Therefore, there were a total of $a + b = a + \frac{8}{9}a = \frac{17}{9}a$ mangoes and oranges.

Also, the total amount of rotten fruit was $2(\frac{2}{3}a) = \frac{4}{3}a$.

Therefore, $\frac{\frac{4}{3}a}{\frac{17}{9}a} = \frac{4}{3}(\frac{9}{17}) = \frac{12}{17}$ of the total number of mangoes and oranges was rotten.

Solution 2:

Since $\frac{2}{3}$ of the mangoes were rotten, $\frac{3}{4}$ of the oranges were rotten, and the number of rotten mangoes equaled the number of rotten oranges, suppose there were 6 rotten mangoes. (We choose 6 as it is a multiple of the numerator of each fraction.) Then the number of rotten oranges will also be 6.

If there were 6 rotten mangoes, then there were a total of $6 \div \frac{2}{3} = 6(\frac{3}{2}) = 9$ mangoes.

If there were 6 rotten oranges, then there were a total of $6 \div \frac{3}{4} = 6(\frac{4}{3}) = 8$ oranges.

Therefore, there were $9 + 8 = 17$ pieces of fruit in total, of which $6 + 6 = 12$ were rotten.

Thus, $\frac{12}{17}$ of the total number of mangoes and oranges was rotten.

NOTE: In Solution 2 we could have used any multiple 6 for the number of rotten mangoes and thus the number of rotten oranges. The final fraction would always reduce to $\frac{12}{17}$. We will show this in general in Solution 3.

Solution 3:

According to the problem, there were an equal number of rotten mangoes and rotten oranges.

Let the number of rotten mangoes and rotten oranges each be $6x$, for some positive integer x .

The total number of mangoes was thus $6x \div \frac{2}{3} = 9x$.

The total number of oranges was thus $6x \div \frac{3}{4} = 8x$.

Therefore, the total number of mangoes and oranges was $9x + 8x = 17x$.

Also, the total number of rotten mangoes and rotten oranges was $6x + 6x = 12x$.

Therefore, $\frac{12x}{17x} = \frac{12}{17}$ of the total number of mangoes and oranges was rotten.



Problème de la semaine

Problème D

Boîtes de beignes

Une boulangerie-pâtisserie est connue pour ses beignes uniques. Lors d'une fin de semaine, trois délicieuses saveurs étaient à l'honneur, chacune étant proposée dans sa propre boîte. Les beignes saveur pêche-caramel se vendaient dans de petites boîtes de 3 beignes chacune, ceux au chocolat dans des boîtes moyennes de 4 beignes chacune et les beignes arc-en-ciel se vendaient dans de grandes boîtes de 8 beignes chacune.

Une fois la fin de semaine terminée, le gérant a déterminé qu'ils avaient vendu 68 boîtes de beignes au total. De plus, un nombre égal de beignes de chaque saveur a été vendu. Combien de beignes la boulangerie-pâtisserie a-t-elle vendus au total ?





Problem of the Week

Problem D and Solution

Boxes of Doughnuts

Problem

A bakery is famous for its specialty doughnuts. One weekend they had three flavours available, each packaged in boxes. Peach caramel doughnuts were sold in small boxes with 3 doughnuts per box, chocolate fudge doughnuts were sold in medium boxes with 4 doughnuts per box, and rainbow doughnuts were sold in large boxes with 8 doughnuts per box.

At the end of the weekend, the owner calculated that they sold 68 boxes of doughnuts in total. Also an equal number of doughnuts of each flavour were sold. How many doughnuts did they sell in total?

Solution

Solution 1

Let n represent the number of doughnuts of each flavour sold. Since there were 3 peach caramel doughnuts per box, then n must be divisible by 3. Since there were 4 chocolate fudge doughnuts per box, then n must be divisible by 4. Since there were 8 rainbow doughnuts per box, then n must be divisible by 8.

Therefore, n must be divisible by 3, 4, and 8. The smallest number divisible by 3, 4, and 8 is 24. (This number is called the *least common multiple* or *LCM*).

If there were 24 doughnuts of each flavour sold, there would have been $24 \div 3 = 8$ boxes of peach caramel doughnuts, $24 \div 4 = 6$ boxes of chocolate fudge doughnuts, and $24 \div 8 = 3$ boxes of rainbow doughnuts. This would mean $8 + 6 + 3 = 17$ boxes of doughnuts would have been sold in total. However, we know that 68 boxes of doughnuts were sold, and since $68 = 17 \times 4$, it follows that 4 times as many doughnuts were sold. Therefore, $24 \times 4 = 96$ doughnuts of each flavour were sold. Thus, the total number of doughnuts sold was $96 \times 3 = 288$.

We can check the correctness of this solution. Since there were 3 peach caramel doughnuts per box, then there were $96 \div 3 = 32$ boxes of peach doughnuts sold. Since there were 4 chocolate fudge doughnuts per box, then there were $96 \div 4 = 24$ boxes of chocolate fudge doughnuts sold. Since there were 8 rainbow doughnuts per box, then there were $96 \div 8 = 12$ boxes of rainbow doughnuts sold. The total number of boxes sold was therefore $32 + 24 + 12 = 68$, as expected.

Solution 2

This solution uses algebra and equation solving. Let n represent the number of doughnuts of each flavour sold. Since there were 3 peach caramel doughnuts per box, then $\frac{n}{3}$ boxes of peach caramel doughnuts were sold. Since there were 4



chocolate fudge doughnuts per box, then $\frac{n}{4}$ boxes of chocolate fudge doughnuts were sold. Since there were 8 rainbow doughnuts per box, then $\frac{n}{8}$ boxes of rainbow doughnuts were sold. Since 68 boxes of doughnuts were sold in total,

$$\begin{aligned}\frac{n}{3} + \frac{n}{4} + \frac{n}{8} &= 68 \\ \frac{8n}{24} + \frac{6n}{24} + \frac{3n}{24} &= 68 \\ \frac{17n}{24} &= 68 \\ 17n &= 68 \times 24 \\ 17n &= 1632 \\ n &= \frac{1632}{17} = 96\end{aligned}$$

Therefore, 96 doughnuts of each flavour were sold. Thus, the total number of doughnuts sold was $96 \times 3 = 288$.

Solution 3

This solution uses ratios. Let n represent the number of doughnuts of each flavour sold. The ratio of the number of boxes of rainbow doughnuts to peach caramel doughnuts sold is

$$\frac{n}{8} : \frac{n}{3} = \frac{3n}{24} : \frac{8n}{24} = 3n : 8n = 3 : 8$$

Similarly, the ratio of the number of boxes of peach caramel doughnuts to chocolate fudge doughnuts sold is $4 : 3 = 8 : 6$. So the ratio of the number of boxes of rainbow doughnuts to peach caramel doughnuts to chocolate fudge doughnuts sold is $3 : 8 : 6$. Let the number of boxes of rainbow doughnuts be $3k$, the number of boxes of peach caramel doughnuts be $8k$, and the number of boxes of chocolate fudge doughnuts be $6k$. Since 68 boxes of doughnuts were sold in total,

$$\begin{aligned}3k + 8k + 6k &= 68 \\ 17k &= 68 \\ k &= \frac{68}{17} = 4\end{aligned}$$

It follows that the number of boxes of rainbow doughnuts sold was $3 \times 4 = 12$, so the number of rainbow doughnuts sold was $12 \times 8 = 96$. Therefore $n = 96$, so 96 doughnuts of each flavour were sold. Thus, the total number of doughnuts sold was $96 \times 3 = 288$.



Problème de la semaine

Problème D

Chiffres en solde !

La Quincaillerie d'Helena liquide un style particulier de chiffres utilisés pour les numéros de maison. Actuellement, il ne reste que cinq 5, quatre 4, trois 3 et deux 2.

Combien de numéros de maison différents à trois chiffres peut-on créer à partir de ces chiffres?

5 5 5 5 5
4 4 4 4
3 3 3
2 2



55555
4444
333
22

Problem of the Week

Problem D and Solution

Number Display

Problem

Helena's Hardware Store is clearing out a particular style of single digits that are used for house numbers. There are currently only five 5s, four 4s, three 3s, and two 2s left.

How many different three-digit house numbers can be made using these single digits?

Solution

Solution 1

Let's suppose that there were three or more 2s available. For the first digit, the customer could choose from the digits 5, 4, 3, and 2. Therefore, there would be 4 choices for the first digit. Similarly, there would be 4 choices for the second digit, and 4 choices for the third digit. This would give $4 \times 4 \times 4 = 64$ possible three-digit house numbers that could be made.

However, there are actually only two 2s available, so not all of these house numbers can be made. In particular, the house number 222 cannot be made, but all others can.

Therefore, $64 - 1 = 63$ different three-digit house numbers can be made using these single digits.

Solution 2

Let's look at three different cases.

Case 1: All three digits in the house number are the same

The house number could then be 555, 444, or 333. The number 222 cannot be made since only two 2s are available. Therefore, there are 3 three-digit house numbers with all three digits the same.

Case 2: Two digits are the same and the third digit is different

There are 4 choices for the digits that are the same, namely 5, 4, 3, and 2. For each of these possible choices, there are 3 choices for the third different digit. For example, if two of the digits are 5, then the third digit could be 4, 3, or 2. Therefore, there are $4 \times 3 = 12$ ways to choose the digits. For each of these choices, there are 3 ways to arrange the digits. For example, suppose the digits are a , a , and b . The house number could be aab , aba , or baa . Therefore, there are $12 \times 3 = 36$ three-digit house numbers with two digits the same and one different.

Case 3: All three digits are different

The customer has 4 choices for the first digit, namely 5, 4, 3, or 2. Once that digit is chosen, there are 3 choices for the second digit. Once the first and second digits are chosen, there are 2 choices for the third digit. Therefore, there are $4 \times 3 \times 2 = 24$ three-digit house numbers with all three digits different.

Therefore, $3 + 36 + 24 = 63$ different three-digit house numbers can be made using these single digits.



Problème de la semaine

Problème D

Choix

Matilda et Yolanda ont chacune sélectionné un nombre entier. Quand on multiplie le nombre de Matilda par la somme des nombres entiers choisis par les deux, on obtient 299 comme produit.

Si le nombre choisi par Matilda est inférieur à celui de Yolanda, détermine toutes les paires possibles de nombres entiers que Matilda et Yolanda auraient pu choisir.





Problem of the Week

Problem D and Solution

Choices

Problem

Matilda and Yolanda each chose an integer. When Matilda's integer is multiplied by the sum of Matilda's and Yolanda's integers, the product is 299.

If Matilda's integer is smaller than Yolanda's integer, determine all possible pairs of integers that Matilda and Yolanda could have chosen.

Solution

Let x represent Matilda's integer and y represent the Yolanda's integer. We're given $x < y$.

The sum of the two integers is $x + y$. We multiply this sum by Matilda's integer, x . The resulting expression is $x(x + y)$. Thus, we want to find all pairs of integers satisfying $x(x + y) = 299$ with $x < y$.

We want the product of two integers to be 299. The factors of 299 are $\pm 1, \pm 13, \pm 23, \pm 299$. Thus, the possible values for x are $\pm 1, \pm 13, \pm 23, \pm 299$.

In the following table, we list all the possible values for x and then determine the corresponding value for y . If $x < y$, then this is a valid possibility. For example, if $x = 1$, then $x + y$ must be 299. Therefore, y must be 298. Since $x < y$, one possibility is Matilda chooses 1 and Yolanda chooses 298.

x	$x + y$	y	$x < y?$
1	299	298	Yes
13	23	10	No
23	13	-10	No
299	1	-298	No
-1	-299	-298	No
-13	-23	-10	Yes
-23	-13	10	Yes
-299	-1	298	Yes

Therefore, there are four pairs of integers that Matilda and Yolanda could have chosen. Matilda could have chosen 1 and Yolanda chose 298, Matilda could have chosen -13 and Yolanda chose -10, Matilda could have chosen -23 and Yolanda chose 10, or Matilda could have chosen -299 and Yolanda chose 298.



Problème de la semaine

Problème D

Davantage de jetons

Madame Chips a 400 jetons de bingo. Chaque jeton est soit bleu, jaune, rouge, vert ou violet.

Le rapport du nombre de jetons bleus au nombre de jetons verts au nombre de jetons rouges est de $1 : 2 : 4$. Le rapport du nombre de jetons verts au nombre de jetons jaunes au nombre de jetons violets est de $1 : 3 : 6$.

Combien y a-t-il de jetons de chaque couleur ?

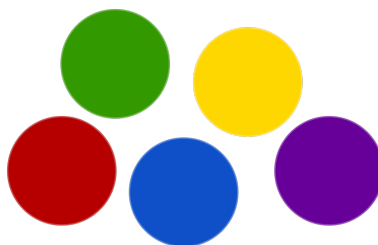



Problem of the Week

Problem D and Solution

More Chips

Problem

Mrs. Chips has 400 bingo chips. Each chip is either blue, yellow, red, green, or purple.

The ratio of the number of blue chips to the number of green chips to the number of red chips is $1 : 2 : 4$. The ratio of the number of green chips to the number of yellow chips to the number of purple chips is $1 : 3 : 6$.

How many chips are there of each colour?

Solution

Let b represent the number of blue chips, g represent the number of green chips, r represent the number of red chips, y represent the number of yellow chips, and p represent the number of purple chips. From here, we present two different solutions.

Solution 1

We are given that $b : g : r = 1 : 2 : 4$ and that $g : y : p = 1 : 3 : 6$. Multiplying by 2, the ratio $1 : 3 : 6$ is equivalent to the ratio $2 : 6 : 12$. Thus, $g : y : p = 2 : 6 : 12$.

We chose to scale this ratio by a factor of 2 so that the only colour common to the two given ratios, green, now has the same number in both of these ratios. We can now combine these to form a single ratio, $b : g : r : y : p = 1 : 2 : 4 : 6 : 12$.

This ratio tells us that for every blue chip, there are 2 green, 4 red, 6 yellow, and 12 purple chips. Thus, if there was only 1 blue chip, then there would be $1 + 2 + 4 + 6 + 12 = 25$ chips in total. However, we are given that the box contains 400 chips in total. Therefore, there are $\frac{400}{25} = 16$ blue chips. Multiplying by 16, the ratio $b : g : r : y : p$ becomes $16 : 32 : 64 : 96 : 192$.

Therefore, there are 16 blue, 32 green, 64 red, 96 yellow, and 192 purple chips.

(Note that there are $16 + 32 + 64 + 96 + 192 = 400$ chips in total.)

Solution 2

We are given that $b : g : r = 1 : 2 : 4$ and that $g : y : p = 1 : 3 : 6$.

The first ratio tells us that $\frac{b}{g} = \frac{1}{2}$, and so $b = \frac{g}{2}$. It also tells us that $\frac{g}{r} = \frac{2}{4}$, and so $r = 2g$.

The second ratio tells us that $\frac{g}{y} = \frac{1}{3}$, and so $y = 3g$. It also tells us that $\frac{g}{p} = \frac{1}{6}$, and so $p = 6g$.

We are given that there are a total of 400 chips. That is, $b + g + r + y + p = 400$.

Substituting $b = \frac{g}{2}$, $r = 2g$, $y = 3g$, and $p = 6g$, this becomes

$$\frac{g}{2} + g + 2g + 3g + 6g = 400$$

$$\frac{25g}{2} = 400$$

$$g = 32$$

Thus, $b = \frac{g}{2} = 16$, $r = 2g = 64$, $y = 3g = 96$, and $p = 6g = 192$.

Therefore, there are 16 blue, 32 green, 64 red, 96 yellow, and 192 purple chips.



Problème de la semaine

Problème D

Quelques cents

Carroll et Arthur ont nettoyé leur maison et ont trouvé un total de 33 pièces de monnaie. Les pièces étaient soit des pièces de 5 cents, soit des pièces de 10 cents, soit des pièces de 25 cents. Il y avait deux fois plus de pièces de 25 cents que de pièces de 10 cents et la valeur totale de toutes les pièces qu'ils ont trouvées était de 5,25 \$.

Combien ont-ils trouvé de chaque type de pièce ?



NOTE : Au Canada, 100 cents équivalent 1 \$.



Problem of the Week

Problem D and Solution

Small Change

Problem

Carroll and Arthur cleaned their house and found a total of 33 coins. The coins were either nickels (5 cent coins), dimes (10 cent coins), or quarters (25 cent coins). There were twice as many quarters as dimes, and the total value of all the coins they found was \$5.25.

How many of each type of coin did they find?

NOTE: In Canada, 100 cents is equal to \$1.

Solution

Let n be the number of nickels, d be the number of dimes, and q be the number of quarters.

From the total number of coins we get the equation

$$n + d + q = 33 \quad (1)$$

From the value of the coins we get the equation

$$5n + 10d + 25q = 525 \quad (2)$$

We also know that $q = 2d$.

Substituting $q = 2d$ into equation (1) and simplifying, we get

$$\begin{aligned} n + d + 2d &= 33 \\ n + 3d &= 33 \end{aligned} \quad (3)$$

Substituting $q = 2d$ into equation (2) and simplifying, we get

$$\begin{aligned} 5n + 10d + 25(2d) &= 525 \\ 5n + 60d &= 525 \\ n + 12d &= 105 \end{aligned} \quad (4)$$

We can isolate n in equation (3) to get $n = 33 - 3d$.

Similarly, we can isolate n in equation (4) to get $n = 105 - 12d$.

Since $n = n$, it follows that

$$\begin{aligned} 33 - 3d &= 105 - 12d \\ -3d + 12d &= 105 - 33 \\ 9d &= 72 \\ d &= 8 \end{aligned}$$

Substituting $d = 8$ into $n = 33 - 3d$, it follows that $n = 33 - 3(8) = 33 - 24 = 9$.

Finally, we substitute $d = 8$ into $q = 2d$, to find $q = 2(8) = 16$.

Therefore, they found 9 nickels, 8 dimes, and 16 quarters.



Problème de la semaine

Problème D

Nouvel an en somme !

On dispose en rangées les nombres entiers strictement positifs en ordre consécutif, chaque rangée contenant sept entiers. C'est-à-dire que la première rangée contient les entiers 1, 2, 3, 4, 5, 6 et 7. La deuxième rangée contient les entiers 8, 9, 10, 11, 12, 13 et 14. La troisième rangée contient les entiers 15, 16, 17, 18, 19, 20 et 21 et ainsi de suite.

1	2	3	4	5	6	7
8	9	10	11	12	13	14
15	16	17	18	19	20	21
⋮	⋮	⋮	⋮	⋮	⋮	⋮

La *somme de rangée* d'une rangée est la somme des entiers dans cette rangée. Par exemple, la somme de rangée de la première rangée est égale à $1 + 2 + 3 + 4 + 5 + 6 + 7 = 28$.

Détermine les nombres dans la rangée dont la somme de rangée est la plus près de 2024.



2024

Problem of the Week

Problem D and Solution

Sum New Year!

Problem

The positive integers are written consecutively in rows, with seven integers in each row. That is, the first row contains the integers 1, 2, 3, 4, 5, 6, and 7. The second row contains the integers 8, 9, 10, 11, 12, 13, and 14. The third row contains the integers 15, 16, 17, 18, 19, 20, and 21, and so on.

1	2	3	4	5	6	7
8	9	10	11	12	13	14
15	16	17	18	19	20	21
⋮	⋮	⋮	⋮	⋮	⋮	⋮

The *row sum* of a row is the sum of the integers in the row. For example, the row sum of the first row is $1 + 2 + 3 + 4 + 5 + 6 + 7 = 28$.

Determine the numbers in the row that has a row sum closest to 2024.

Solution**Solution 1**

The last number in row 1 is 7, the last number in row 2 is 14, and the last number in row 3 is 21. Observe that the last number in each row is a multiple of 7. Furthermore, the last number in row n is $7n$. Since the last number in row n is $7n$, the six preceding numbers in the row are $7n - 1$, $7n - 2$, $7n - 3$, $7n - 4$, $7n - 5$, and $7n - 6$.

The sum of the numbers in row n is

$$(7n - 6) + (7n - 5) + (7n - 4) + (7n - 3) + (7n - 2) + (7n - 1) + 7n = 49n - 21$$

We want to find the integer value of n so that $49n - 21$ is as close to 2024 as possible.

$$49n - 21 = 2024$$

$$49n = 2045$$

$$n \approx 41.7$$

The closest integer to 41.7 is 42. The row sum of row 42 is $49n - 21 = 49(42) - 21 = 2037$. The last number in row 42 is $7 \times 42 = 294$. The seven integers in the row 42 are 288, 289, 290, 291,



292, 293, and 294. Row 41 contains the integers 281, 282, 283, 284, 285, 286, and 287, and has row sum equal to 1988. This row sum is farther from 2024 than 2037, the row sum of row 42.

Therefore, row 42 has the row sum closest to 2024. This row contains the integers 288, 289, 290, 291, 292, 293, and 294.

The second solution approaches the problem by establishing a linear relationship.

Solution 2

Let x represent the row number and y represent the sum of the integers in the row. Observe that the seventh integer in any row is a multiple of 7. In fact, the seventh integer in any row is 7 times the row number or $7x$. The following table of values summarizes the row sums for the first three rows.

Row Number (x)	Row Sum (y)
1	28
2	77
3	126

Notice that the y values increase by 49 as the x values increase by 1. We will verify that this is true. In Solution 1 we saw that the sum of the numbers in row n is $49n - 21$. Therefore, the sum of the numbers in row x is $49x - 21$ and the sum of the numbers in row $(x + 1)$ is $49(x + 1) - 21 = (49x - 21) + 49$. Thus, the y values increase by 49 as the x values increase by 1. This tells us that the sum of the fourth row should be $126 + 49 = 175$. We can verify this by adding $22 + 23 + 24 + 25 + 26 + 27 + 28$, the numbers in the fourth row. The sum is indeed 175.

As the values of x increase by 1, the values of y increase by 49. The relation is linear. The slope is $\frac{\Delta y}{\Delta x} = \frac{49}{1} = 49$. Substituting $x = 1$, $y = 28$, $m = 49$ into the equation $y = mx + b$, we get

$$\begin{aligned}28 &= 49(1) + b \\ -21 &= b\end{aligned}$$

Thus, the equation of the line which passes through the points in the relation is $y = 49x - 21$. Note that x and y are positive integers. We want to find the value of x , the row number, so that the value of y , the row sum, is as close to 2024 as possible.

$$\begin{aligned}49x - 21 &= 2024 \\ 49x &= 2045 \\ x &\approx 41.7\end{aligned}$$

The closest integer to 41.7 is 42. When $x = 42$, the row sum is $y = 49(42) - 21 = 2037$. The row sum when $x = 41$ is $y = 49(41) - 21 = 1988$. The row sum 2037 is closer to 2024 than the row sum 1988.

Therefore, row 42 has the row sum closest to 2024. The seventh number in row 42 is $7 \times 42 = 294$. Thus, this row contains the integers 288, 289, 290, 291, 292, 293, and 294.



Problème de la semaine

Problème D

Une masse encore plus problématique

George a trois objets, chacun ayant une masse différente. Il pèse les objets par paires et note la masse de chaque paire d'objets. Plus tard, il se rend compte qu'il a oublié de peser les objets individuellement. Hélas, il n'a plus accès à une balance. Les trois masses qu'il a notées sont 2986 g, 3464 g et 3550 g. Détermine la masse de l'objet le plus lourd.

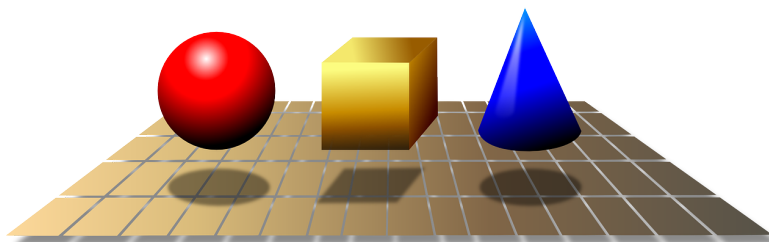

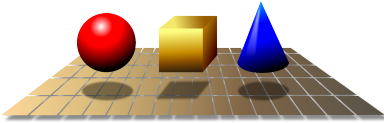

Problem of the Week

Problem D and Solution

A Weightier Problem

Problem

George has three objects, each of a different mass. He weighs the objects in pairs and records the mass of each pair of objects. Later, he realizes that he forgot to weigh the objects individually, but no longer has access to a scale. The three recorded masses are 2986 g, 3464 g, and 3550 g. Determine the mass of the heaviest object.

Solution

Let a represent the mass, in grams, of the lightest object

Let c represent the mass, in grams, of the heaviest object.

Let b represent the mass, in grams, of the third object.

The smallest recorded mass is created by adding the masses of the two lightest objects together. Therefore,

$$a + b = 2986 \quad (1)$$

The largest recorded mass is created by adding the masses of the two heaviest objects together. Therefore,

$$b + c = 3550 \quad (2)$$

Thus, it must be the case that

$$a + c = 3464 \quad (3)$$

At this point we could solve a system of equations involving three equations and three unknowns. Instead, we will add equations (1), (2), and (3) together.

$$\begin{aligned}(a + b) + (b + c) + (a + c) &= 2986 + 3550 + 3464 \\ 2a + 2b + 2c &= 10\,000 \\ 2(a + b + c) &= 10\,000 \\ a + b + c &= 5000\end{aligned} \quad (4)$$

From equation (4), we know that the total mass of the three objects is 5000 g. But from equation (1), the mass of the two lighter objects is 2986 g. We can subtract equation (1) from equation (4) to obtain the mass of the heaviest object.

$$\begin{aligned}(a + b + c) - (a + b) &= 5000 - 2986 \\ a + b + c - a - b &= 2014 \\ c &= 2014\end{aligned}$$

Therefore, the heaviest object has a mass of 2014 g. Although we are not asked to, from here, we could determine that the other objects have mass of 1450 g and mass of 1536 g.



Problème de la semaine

Problème D

Utiliser les restes

Un nombre entier strictement positif de trois chiffres n a la propriété suivante: lorsque 2024 est divisé par n , il y a un reste de 4. Quelle est la somme de tous les nombres entiers strictement positifs de trois chiffres qui ont cette propriété ?

$$n \overline{) 2024} \quad ?$$



$$n \overline{) 2024} \quad ?$$

Problem of the Week

Problem D and Solution

Using Leftovers

Problem

A three-digit positive integer n has the property that when 2024 is divided by n , the remainder is 4. What is the sum of all such three-digit positive integers n ?

Solution

Let p be the quotient when 2024 is divided by n . Since the remainder is 4, it follows that $np + 4 = 2024$. Thus, $np = 2020$.

Using the prime factorization of 2020 we obtain $2020 = 2 \times 2 \times 5 \times 101$. From this we can determine all the possible pairs of positive integers that multiply to 2020. These are summarized below.

$$1 \times 2020, \quad 2 \times 1010, \quad 4 \times 505, \quad 5 \times 404, \quad 10 \times 202, \quad 20 \times 101$$

Since n is a three-digit positive integer, it follows that the only possible values for n are 101, 202, 404, or 505. The sum of these is $101 + 202 + 404 + 505 = 1212$.



Problème de la semaine

Problème D

Encore un test éclair moyen

On a les informations suivantes concernant un test éclair récent portant sur les moyennes:

- Le test comportait trois questions.
- Chaque question valait 1 point.
- Chaque question a été notée juste ou fausse (pas de note partielle).
- 50 % des élèves ont répondu correctement aux 3 questions.
- 5 % des élèves n'ont eu aucune bonne réponse.
- La moyenne générale de la classe était de 2,3 sur 3.

Détermine le pourcentage des élèves qui ont répondu correctement à exactement 1 question et le pourcentage des élèves qui ont répondu correctement à exactement 2 questions.





Problem of the Week

Problem D and Solution

Another Average Quiz

Problem

On a recent quiz about averages, the following information is known:

- There were three questions on the quiz.
- Each question was worth 1 mark.
- Each question was marked either right or wrong (no part marks).
- 50% of the students got all 3 questions correct.
- 5% of the students got no question correct.
- The class average mark was 2.3 out of 3.

Determine the percentage of students who got exactly 1 question correct and the percentage of students who got exactly 2 questions correct.

Solution

Solution 1

In this solution, we will use the information given for a class of 100 students, and we will use only one variable.

To determine the average, we must determine the sum of all the marks and divide by the number of students.

Let x represent the percent of students who got exactly 2 questions correct.

Then $100 - 50 - 5 - x = (45 - x)$ percent of the students got exactly 1 question correct.

Since 50% of the students got all 3 questions correct, then 50 students each scored 3 marks and earned a total of $50 \times 3 = 150$ marks.

Since $x\%$ of the students got exactly 2 questions correct, then x students each scored 2 marks and earned a total of $x \times 2 = 2x$ marks.

Since $(45 - x)\%$ of the students got exactly 1 question correct, then $(45 - x)$ students each scored 1 mark and earned a total of $(45 - x) \times 1 = (45 - x)$ marks.

Since 5% of the students got no questions correct, 5 students scored 0 marks and earned a total of $5 \times 0 = 0$ marks.

The total number of marks earned by the 100 students was $150 + 2x + (45 - x) + 0 = x + 195$.



We know that the average mark was 2.3, so

$$\begin{aligned}\frac{x + 195}{100} &= 2.3 \\ x + 195 &= 230 \\ x &= 35 \\ 45 - x &= 10\end{aligned}$$

Therefore, 35% of the students got exactly 2 questions correct and 10% of the students got exactly 1 question correct.

Solution 2

In this solution, we will use the information given for a class of 100 students, we will use two variables.

To determine the average, we must determine the sum of all the marks and divide by the number of students.

Let x represent the percent who got exactly 2 questions correct.

Let y represent the percent who got exactly 1 question correct.

Then, $50 + x + y + 5 = 100$, which simplifies to

$$x + y = 45 \tag{1}$$

Since 50% of the students got all 3 questions correct, then 50 students each scored 3 marks and earned a total of $50 \times 3 = 150$ marks.

Since $x\%$ of the students got exactly 2 questions correct, then x students each scored 2 marks and earned a total of $x \times 2 = 2x$ marks.

Since $y\%$ of the students got exactly 1 question correct, y students each scored 1 mark and earned a total of $y \times 1 = y$ marks.

Since 5% of the students got no questions correct, 5 students scored 0 marks and earned a total of $5 \times 0 = 0$ marks.

The total number of marks earned by the 100 students was $150 + 2x + y + 0 = 2x + y + 150$.

We know that the average score was 2.3, so

$$\begin{aligned}\frac{2x + y + 150}{100} &= 2.3 \\ 2x + y + 150 &= 230 \\ 2x + y &= 80\end{aligned} \tag{2}$$

Subtracting equation (1) from equation (2), we obtain $x = 35$. Substituting $x = 35$ into equation (1), we obtain $y = 10$.

Therefore, 35% of the students got exactly 2 questions correct and 10% of the students got exactly 1 question correct.



Solution 3

In this solution, we will use three variables but we will not assume a class size.

To determine the average, we must determine the sum of all the marks and divide by the number of students.

Let n represent the number of students who wrote the quiz, where n is a positive integer.

Let x represent the percent who got exactly 2 questions correct.

Let y represent the percent who got exactly 1 question correct.

Then, $50 + x + y + 5 = 100$ which simplifies to

$$x + y = 45 \tag{1}$$

Since 50% of the students got all 3 questions correct, then $\frac{50}{100}n$ students each scored 3 marks and earned a total of $\frac{50}{100}n \times 3 = \frac{150n}{100}$ marks.

Since $x\%$ of the students got exactly 2 questions correct, then $\frac{x}{100}n$ students each scored 2 marks and earned a total of $\frac{x}{100}n \times 2 = \frac{2xn}{100}$ marks.

Since $y\%$ of the students got exactly 1 question correct, then $\frac{y}{100}n$ students each scored 1 mark and earned a total of $\frac{y}{100}n \times 1 = \frac{yn}{100}$ marks.

Since 5% of the students got no questions correct, 5 students scored 0 marks and earned a total of $5 \times 0 = 0$ marks.

The total number of marks earned by the n students was $\frac{150n}{100} + \frac{2xn}{100} + \frac{yn}{100} = \frac{n}{100}(150 + 2x + y)$.

We know that the average score was 2.3 and n is a positive integer, so

$$\begin{aligned} \frac{\frac{n}{100}(150 + 2x + y)}{n} &= 2.3 \\ 150 + 2x + y &= 230 \\ 2x + y &= 80 \end{aligned} \tag{2}$$

Subtracting equation (1) from equation (2), we obtain $x = 35$. Substituting $x = 35$ into equation (1), we obtain $y = 10$.

Therefore, 35% of the students got exactly 2 questions correct and 10% of the students got exactly 1 question correct.



Problème de la semaine

Problème D

Année bissextile 2

La plupart des gens croient qu'une année compte 365 jours, mais en réalité, elle en compte légèrement plus. Pour ajuster ce surplus de temps, on a recours aux années bissextiles. Ces dernières sont des années qui contiennent un jour de plus.

Mara utilise l'organigramme ci-contre pour déterminer si une année donnée est bissextile ou non. D'après l'organigramme :

- l'année 2018 n'était **pas** une année bissextile car 2018 n'est pas divisible par 4.
- l'année 2016 était une année bissextile car 2016 est divisible par 4, mais n'est pas divisible par 100.
- l'année 2100 ne sera **pas** une année bissextile car 2100 est divisible par 4 et par 100, mais n'est pas divisible par 400.
- l'année 2000 était une année bissextile car 2000 est divisible par 4, par 100 et par 400.

Si Mara choisit au hasard une année après l'an 2000, quelle est la probabilité pour qu'elle choisisse une année bissextile ?

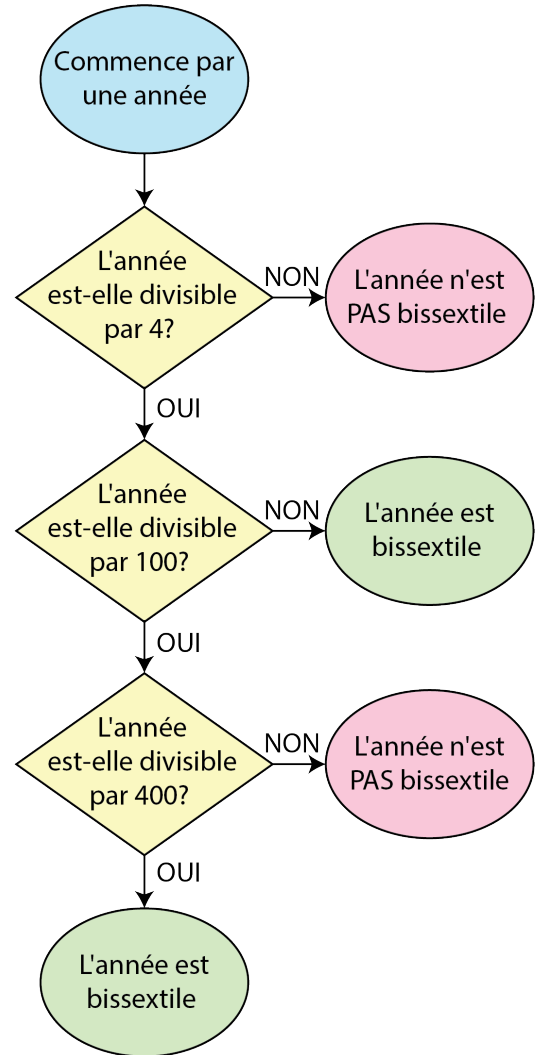



Problem of the Week

Problem D and Solution

A Big Leap

Problem

Most people think of a year as 365 days, however it is actually slightly more than 365 days. To account for this extra time we use leap years, which are years containing one extra day.

Mara uses the flowchart shown to determine whether or not a given year is a leap year. She has concluded the following:

- 2018 was **not** a leap year because 2018 is not divisible by 4.
- 2016 was a leap year because 2016 is divisible by 4, but not 100.
- 2100 will **not** be a leap year because 2100 is divisible by 4 and 100, but not 400.
- 2000 was a leap year because 2000 is divisible by 4, 100, and 400.

If Mara chooses a year greater than 2000 at random, what is the probability that she chooses a leap year?

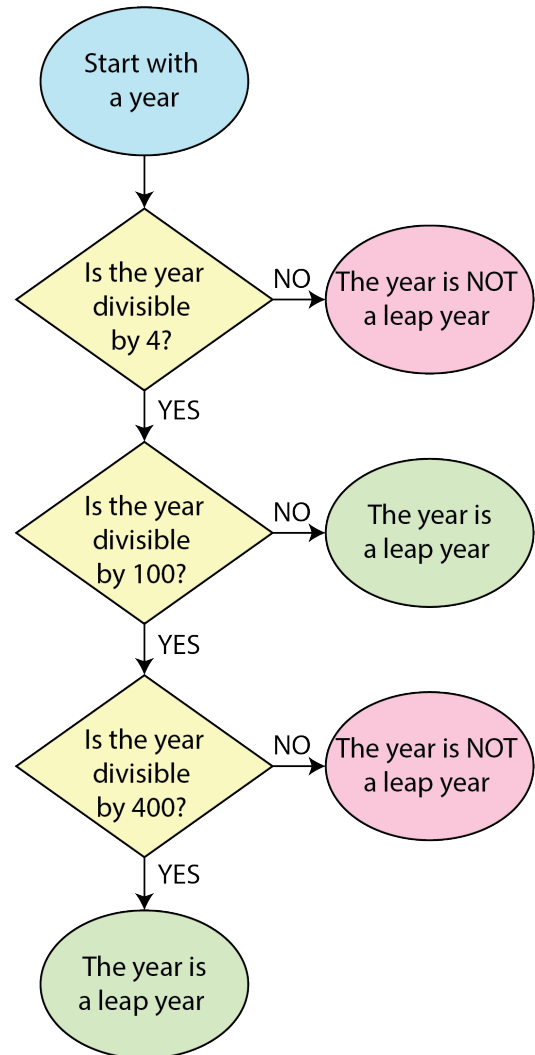



Solution

The probability of an event occurring is calculated as the number of favourable outcomes (that is, the number of outcomes where the event occurs) divided by the total number of possible outcomes. This is an issue in our problem because the number of years greater than 2000 is infinite. However, the cycle of leap years repeats every 400 years. For example, since 2044 is a leap year, so is 2444.

Thus, to determine the probability, we need to count the number of leap years in a 400-year cycle. From the flowchart we can determine that leap years are either

- multiples of 4 that are not also multiples of 100, or
- multiples of 4, 100, and 400.

Note that we can simplify the second case to just multiples of 400, since any multiple of 400 will also be a multiple of 4 and 100.

The number of multiples of 4 in a 400-year cycle is $\frac{400}{4} = 100$. However, we have included the multiples of 100, so we need to subtract these multiples. There are $\frac{400}{100} = 4$ multiples of 100 in a 400-year cycle. Thus, there are $100 - 4 = 96$ multiples of 4 that are not multiples of 100. We now need to add back the the multiples of 400. There is $\frac{400}{400} = 1$ multiple of 400 in a 400-year cycle. Thus, there are $96 + 1 = 97$ numbers that are multiples of 4 and are not multiples of 100, or that are multiples of 400.

Therefore, for every 400-year cycle, 97 of these years will be a leap year.

Therefore, the probability of Mara choosing a leap year is $\frac{97}{400} = 0.2425$.



Problème de la semaine

Problème D

Carrés de Pi

Le jour de Pi est une célébration annuelle de la constante mathématique π . Le jour de Pi est célébré le 14 mars, car 3, 1 et 4 sont les trois premiers chiffres significatifs de π .

Archimède a déterminé des bornes inférieures pour π en trouvant les périmètres des polygones réguliers inscrits dans un cercle de diamètre 1. (Les sommets d'un polygone inscrit dans un cercle sont tous situés sur le cercle.) Il a également déterminé des bornes supérieures pour π en trouvant les périmètres des polygones réguliers circonscrits à un cercle de diamètre 1. (Un polygone circonscriptible est un polygone possédant un cercle inscrit, soit un cercle tangent à tous ces côtés. Autrement dit, chaque côté du polygone touche le cercle en un point.)

Dans ce problème, on va déterminer une borne inférieure pour π et une borne supérieure pour π en considérant un carré inscrit dans un cercle de diamètre 1 et un carré circonscrit à un cercle de diamètre 1.

Considérons un cercle de centre C et de diamètre 1. Puisque le cercle a un diamètre de 1, sa circonférence est égale à π . Considérons maintenant le carré inscrit $ABDE$ et le carré circonscrit $FGHJ$.

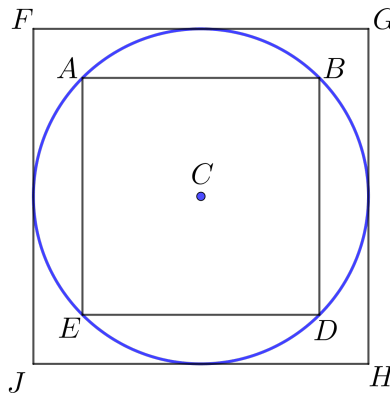

Le périmètre du carré $ABDE$ est inférieur à la circonférence du cercle, π , ce qui nous permet d'obtenir une borne inférieure pour la valeur de π . Le périmètre du carré $FGHJ$ est supérieur à la circonférence du cercle, π , ce qui nous permet d'obtenir une borne supérieure pour la valeur de π .

En utilisant ces carrés, détermine une borne inférieure et une borne supérieure pour π .

NOTE: Pour ce problème, les renseignements suivants peuvent s'avérer utiles:

1. Pour un cercle de centre C , les diagonales d'un carré inscrit se coupent à angle droit en C .
2. Pour un cercle de centre C , les diagonales d'un carré circonscrit se coupent à angle droit en C .
3. Si une droite est tangente à un cercle, alors cette droite est perpendiculaire au rayon qui relie le centre du cercle et le point de tangence.

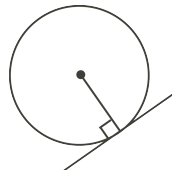



Problem of the Week

Problem D and Solution

Pi Squares

Problem

Pi Day is an annual celebration of the mathematical constant π . Pi Day is observed on March 14, since 3, 1, and 4 are the first three significant digits of π .

Archimedes determined lower bounds for π by finding the perimeters of regular polygons inscribed in a circle with diameter of length 1. (An inscribed polygon of a circle has all of its vertices on the circle.) He also determined upper bounds for π by finding the perimeters of regular polygons circumscribed in a circle with diameter of length 1. (A circumscribed polygon of a circle has all sides tangent to the circle. That is, each side of the polygon touches the circle in one spot.)

In this problem, we will determine a lower bound for π and an upper bound for π by considering an inscribed square and a circumscribed square in a circle of diameter 1.

Consider a circle with centre C and diameter 1. Since the circle has diameter 1, it has circumference equal to π . Now consider the inscribed square $ABDE$ and the circumscribed square $FGHJ$.

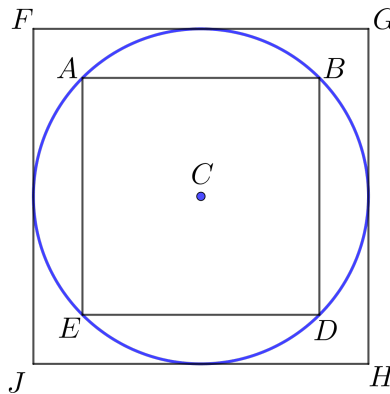

The perimeter of square $ABDE$ will be less than the circumference of the circle, π , and will thus give us a lower bound for the value of π . The perimeter of square $FGHJ$ will be greater than the circumference of the circle, π , and will thus give us an upper bound for the value of π .

Using these squares, determine a lower bound and an upper bound for π .

NOTE: For this problem, you may want to use the following known results about circles:

1. For a circle with centre C , the diagonals of an inscribed square meet at 90° at C .
2. For a circle with centre C , the diagonals of a circumscribed square meet at 90° at C .
3. If a line is tangent to a circle, then the line is perpendicular to the radius drawn to the point of tangency.

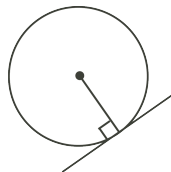



Solution

For the inscribed square $ABDE$, draw line segments AC and BC . Both AC and BC are radii of the circle with diameter 1, so $AC = BC = 0.5$.

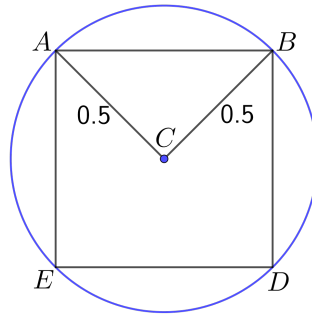

Since the diagonals of square $ABDE$ meet at 90° at C , it follows that $\triangle ACB$ is a right-angled triangle with $\angle ACB = 90^\circ$. We can use the Pythagorean Theorem to find the length of AB .

$$\begin{aligned} AB^2 &= AC^2 + BC^2 \\ &= (0.5)^2 + (0.5)^2 \\ &= 0.25 + 0.25 \\ &= 0.5 \end{aligned}$$

Therefore, $AB = \sqrt{0.5}$, since $AB > 0$.

Since AB is one of the sides of the inscribed square, the perimeter of square $ABDE$ is equal to $4 \times AB = 4\sqrt{0.5}$. This gives us a lower bound for π . That is, we know $\pi > 4\sqrt{0.5} \approx 2.828$.

For the circumscribed square, let M be the point of tangency on side FJ and let N be the point of tangency on GH . Draw radii CM and CN . Since M is a point of tangency, we know that $\angle FMC = 90^\circ$, and thus CM is parallel to FG . Similarly, CN is parallel to GH .

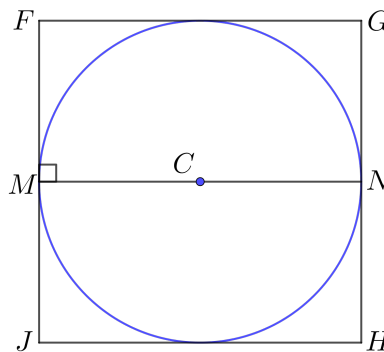

Thus, MN is a straight line segment, and since it passes through C , the centre of the circle, MN must also be a diameter of the circle. Thus, $MN = 1$. Also, $FMNG$ is a rectangle, so $FG = MN = 1$ and the perimeter of square $FGHJ$ is equal to $4 \times FG = 4(1) = 4$. This gives us an upper bound for π . That is, we know $\pi < 4$.

Therefore, a lower bound for π is $4\sqrt{0.5} \approx 2.828$ and an upper bound for π is 4. That is, $4\sqrt{0.5} < \pi < 4$.

NOTE: Since we know that $\pi \approx 3.14$, these are not the best bounds for π . Archimedes used regular polygons with more sides to get better bounds. In the Problem of the Week E problem, we investigate using regular hexagons to get better bounds.



Problème de la semaine

Problème D

Longueur d'avance

Gabi et Silvio s'entraînent pour une course de vélo. Ils habitent dans la même rue, mais la maison de Silvio se trouve à 2 km à l'est de celle de Gabi. Dimanche matin, à 7 h, ils commencent chacun à faire du vélo en direction est depuis leur maison. Si Gabi roule à une vitesse constante de 24 km/h et Silvio à une vitesse constante de 18 km/h, à quelle heure Gabi rattrapera-t-elle Silvio ?

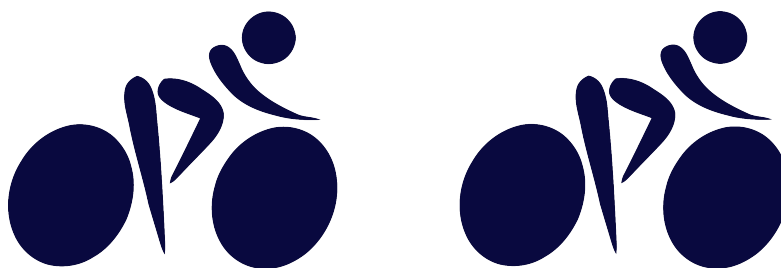



Problem of the Week

Problem D and Solution

Head Start

Problem

Gabi and Silvio are training for a cycling race. They live on the same street, but Silvio's house is 2 km east of Gabi's. On Sunday morning at 7 a.m. they each start biking east from their house. If Gabi bikes at a constant speed of 24 km/h and Silvio bikes at a constant speed of 18 km/h, at what time will Gabi catch up to Silvio?

Solution

For the first two solutions we will use the formula: $\text{time} = \frac{\text{distance}}{\text{speed}}$.

For the third solution we will use the formula: $\text{distance} = \text{speed} \times \text{time}$.

Solution 1

Since Gabi bikes at 24 km/h and Silvio bikes at 18 km/h, then Gabi gains 6 km/h on Silvio.

Since Silvio starts 2 km east of Gabi, then it takes Gabi $\frac{2}{6} = \frac{1}{3}$ of an hour or $\frac{1}{3} \times 60 = 20$ minutes to catch up to Silvio. Since they started biking at 7 a.m., Gabi will catch up to Silvio at 7:20 a.m.

Solution 2

Silvio bikes at 18 km/h or $\frac{18}{60} = \frac{3}{10}$ km/min. Gabi bikes at 24 km/h or $\frac{24}{60} = \frac{2}{5}$ km/min. Therefore Gabi gains $\frac{2}{5} - \frac{3}{10} = \frac{1}{10}$ km/min on Silvio.

Since Silvio started 2 km east of Gabi, then it takes Gabi $2 \div \frac{1}{10} = 20$ minutes to catch Silvio. Since they started biking at 7 a.m., Gabi will catch up to Silvio at 7:20 a.m.

Solution 3

Suppose it takes t hours for Gabi to catch up to Silvio. Then Silvio has biked $18 \text{ km/h} \times t \text{ h} = 18t \text{ km}$, and Gabi has biked $24 \text{ km/h} \times t \text{ h} = 24t \text{ km}$.

Since Silvio starts 2 km east of Gabi, then when they meet, Gabi will have travelled 2 km further than Silvio. That is,

$$24t = 18t + 2$$

$$6t = 2$$

$$t = \frac{1}{3}$$

Therefore, it takes Gabi $\frac{1}{3}$ of an hour, or 20 minutes to catch up to Silvio. Since they started biking at 7 a.m., Gabi will catch up to Silvio at 7:20 a.m.



Problème de la semaine

Problème D

La même puissance

Parfois, deux puissances qui n'ont pas la même base ont tout de même des valeurs égales. Par exemple, $9^3 = 27^2$ et $(-5)^4 = 25^2$.

Si x et y sont des nombres entiers, trouve tous les couples (x, y) qui vérifient l'équation

$$(x - 1)^{x+y} = 8^2$$

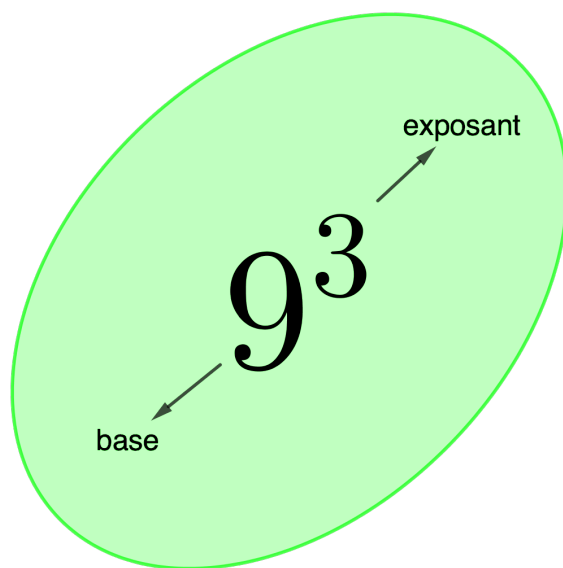



Problem of the Week

Problem D and Solution

The Same Power

Problem

Sometimes two powers that are not written with the same base are still equal in value. For example, $9^3 = 27^2$ and $(-5)^4 = 25^2$.

If x and y are integers, find all ordered pairs (x, y) that satisfy the equation

$$(x - 1)^{x+y} = 8^2$$

Solution

Since $8^2 = 64$, we want to look at how we can express 64 as a^b where a and b are integers. There are six ways to do so. We can do so as 64^1 , 8^2 , 4^3 , 2^6 , $(-2)^6$, and $(-8)^2$.

We use these powers and the expression $(x - 1)^{x+y}$ to find values for x and y .

- The power $(x - 1)^{x+y}$ is expressed as 64^1 when $x - 1 = 64$ and $x + y = 1$. Then $x = 65$ and $y = -64$ follows. Thus $(65, -64)$ is one pair.
- The power $(x - 1)^{x+y}$ is expressed as 8^2 when $x - 1 = 8$ and $x + y = 2$. Then $x = 9$ and $y = -7$ follows. Thus $(9, -7)$ is one pair.
- The power $(x - 1)^{x+y}$ is expressed as 4^3 when $x - 1 = 4$ and $x + y = 3$. Then $x = 5$ and $y = -2$ follows. Thus $(5, -2)$ is one pair.
- The power $(x - 1)^{x+y}$ is expressed as 2^6 when $x - 1 = 2$ and $x + y = 6$. Then $x = 3$ and $y = 3$ follows. Thus $(3, 3)$ is one pair.
- The power $(x - 1)^{x+y}$ is expressed as $(-2)^6$ when $x - 1 = -2$ and $x + y = 6$. Then $x = -1$ and $y = 7$ follows. Thus $(-1, 7)$ is one pair.
- The power $(x - 1)^{x+y}$ is expressed as $(-8)^2$ when $x - 1 = -8$ and $x + y = 2$. Then $x = -7$ and $y = 9$ follows. Thus $(-7, 9)$ is one pair.

Therefore, there are six ordered pairs that satisfy the equation.

They are $(65, -64)$, $(9, -7)$, $(5, -2)$, $(3, 3)$, $(-1, 7)$, and $(-7, 9)$.



Problème de la semaine

Problème D

Effacer 2

Ajay écrit les nombres entiers strictement positifs de 1 à 1000 sur un tableau. Ensuite, Jamilah efface tous les nombres qui sont des multiples de 9. Puis, Magdalena efface tous les nombres qui contiennent le chiffre 9. Combien reste-t-il de nombres sur le tableau ?

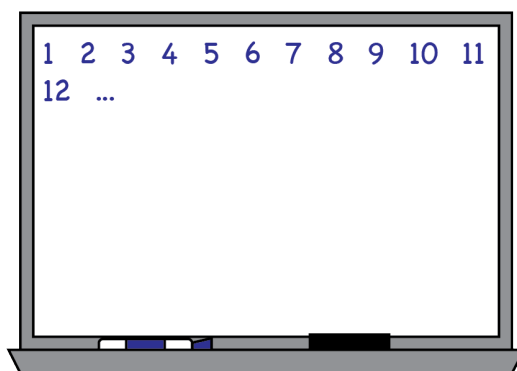

REMARQUE:

La propriété suivante peut s'avérer utile:

Un nombre est divisible par 9 si la somme de ses chiffres est divisible par 9. Par exemple, le nombre 214578 est divisible par 9 puisque $2 + 1 + 4 + 5 + 7 + 8 = 27$ et que 27 est divisible par 9. En fait, $214578 = 9 \times 23842$.

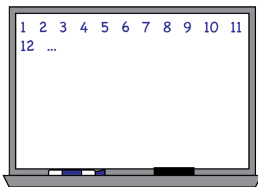

Problem of the Week

Problem D and Solution

Wipe Away 2

Problem

Ajay writes the positive integers from 1 to 1000 on a whiteboard. Jamilah then erases all the numbers that are multiples of 9. Magdalena then erases all the remaining numbers that contain the digit 9. How many numbers are left on the whiteboard?

NOTE: In solving this problem, it may be helpful to use the fact that a number is divisible by 9 exactly when the sum of its digits is divisible by 9. For example, the number 214578 is divisible by 9 since $2 + 1 + 4 + 5 + 7 + 8 = 27$, which is divisible by 9. In fact, $214578 = 9 \times 23842$.

Solution

We first calculate the number of integers that Jamilah erases, which is the number of multiples of 9 between 1 and 1000. Since $1000 = (111 \times 9) + 1$, there are 111 multiples of 9 between 1 and 1000. Thus, Jamilah erases 111 numbers from the whiteboard.

Now let's figure out how many of the integers from 1 to 1000 contain the digit 9. The integers from 1 to 100 that contain the digit 9 are 9, 19, ..., 79, 89 as well as 90, 91, ..., 97, 98, 99. Thus, there are 19 positive integers from 1 to 100 that contain the digit 9. Since there are 19 integers from 1 to 100 that contain the digit 9, it follows that there are $19 \times 9 = 171$ integers from 1 to 899 that contain the digit 9.

Between 900 and 1000, there are 100 integers that contain the digit 9, namely, every number except for 1000. Thus, in total, $171 + 100 = 271$ of the integers from 1 to 1000 contain the digit 9.

However, some of the integers that contain the digit 9 are also multiples of 9, so were erased by Jamilah. To determine how many of these such numbers there are, we use the fact that a number is divisible by 9 exactly when the sum of its digits is divisible by 9.

- The only one-digit number that contains the digit 9 and is also a multiple of 9 is 9 itself.
- The only two-digit numbers that contain the digit 9 and are also multiples of 9 are 90 and 99.
- To find the three-digit numbers that contain the digit 9 and are also multiples of 9, we will look at their digit sum.



- **Case 1:** Three digit-numbers with a digit sum of 9:
The only possibility is 900. Thus, there is 1 number.
- **Case 2:** Three digit-numbers with a digit sum of 18:
 - * If two of the digits are 9, then the other digit must be 0. The only possibilities are 909 and 990. Thus, there are 2 numbers.
 - * If only one of the digits is 9, then the other two digits must add to 9. The possible digits are 9, 4, 5, or 9, 3, 6, or 9, 2, 7, or 9, 8, 1. For each of these sets of digits, there are 3 choices for the hundreds digit. Once the hundreds digit is chosen, there are 2 choices for the tens digit, and then the remaining digit must be the ones digit. Thus, there are $3 \times 2 = 6$ possible three-digit numbers for each set of digits. Since there are 4 sets of digits, then there are $4 \times 6 = 24$ possible numbers.
- **Case 3:** Three digit-numbers with a digit sum of 27:
The only possibility is 999. Thus, there is 1 number.

Therefore, there are $1 + 2 + 24 + 1 = 28$ three-digit numbers from 1 to 1000 that contain the digit 9, and are also multiples of 9.

Thus, there are $1 + 2 + 28 = 31$ numbers that contain the digit 9, but were erased by Jamilah. It follows that Magdalena erases $271 - 31 = 240$ numbers from the whiteboard.

Hence, the number of numbers left on the whiteboard is $1000 - 111 - 240 = 649$.



Problème de la semaine

Problème D

Jeu de réflexions

Le triangle ABC a pour sommets $A(2, 1)$, $B(5, 8)$ et $C(1, c)$ avec $c > 0$.

Les sommets A et B subissent une réflexion par rapport à l'axe des ordonnées tandis que le sommet C subit une réflexion par rapport à l'axe des abscisses. Les trois points de l'image sont colinéaires. C'est-à-dire que les trois points sont situés sur une même droite.

Détermine les coordonnées de C .

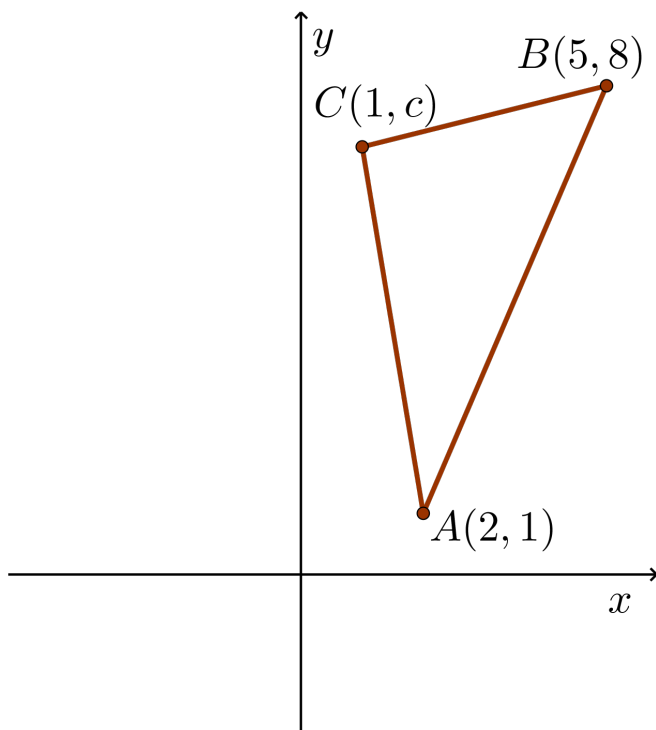



Problem of the Week

Problem D and Solution

Reflect on This

Problem

$\triangle ABC$ has vertices $A(2, 1)$, $B(5, 8)$, and $C(1, c)$, where $c > 0$.

Vertices A and B are reflected in the y -axis, and vertex C is reflected in the x -axis. The three image points are collinear. That is, a line passes through the three image points.

Determine the coordinates of C .

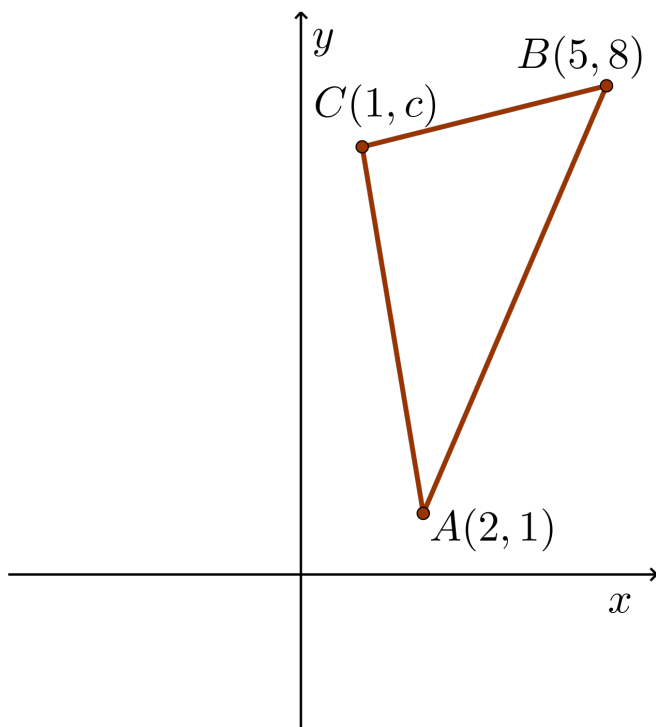

Solution

When a point is reflected in the y -axis, the image point has the same y -coordinate and the x -coordinate is -1 multiplied by the pre-image x -coordinate. Thus, the image of $A(2, 1)$ is $A'(-2, 1)$, and the image of $B(5, 8)$ is $B'(-5, 8)$.

When a point is reflected about the x -axis, the image point has the same x -coordinate and the y -coordinate is -1 multiplied by the pre-image y -coordinate. Thus, the image of $C(1, c)$ is $C'(1, -c)$.

The three image points, A' , B' , and C' , are collinear.

Solution 1

In this solution, we find the equation of the line through the three image points. We begin by first determining the slope of the line, and then the y -intercept.



$$\text{slope}(A'B') = \frac{8-1}{-5-(-2)} = -\frac{7}{3}$$

Since $A'(-2, 1)$ lies on the line, we can substitute $x = -2$, $y = 1$, and $m = -\frac{7}{3}$ into $y = mx + b$.

$$\begin{aligned} 1 &= -\frac{7}{3}(-2) + b \\ 1 &= \frac{14}{3} + b \\ b &= 1 - \frac{14}{3} \\ &= -\frac{11}{3} \end{aligned}$$

Thus, the equation of the line through the three image points is $y = -\frac{7}{3}x - \frac{11}{3}$. Since the point $C'(1, -c)$ lies on this line, we can substitute $x = 1$ and $y = -c$ into the equation to solve for c .

Thus, $-c = -\frac{7}{3}(1) - \frac{11}{3} = -\frac{18}{3} = -6$ and $c = 6$ follows.

Therefore, the coordinates of C are $(1, 6)$.

Solution 2

Since $A'(-2, 1)$, $B'(-5, 8)$, and $C'(1, -c)$ are collinear, $\text{slope}(A'B') = \text{slope}(B'C')$.

$$\begin{aligned} \text{slope}(A'B') &= \text{slope}(B'C') \\ \frac{8-1}{-5-(-2)} &= \frac{-c-8}{1-(-5)} \\ \frac{7}{-3} &= \frac{-c-8}{6} \\ 42 &= 3c+24 \\ 18 &= 3c \\ 6 &= c \end{aligned}$$

Therefore, the coordinates of C are $(1, 6)$.