

Problème de la Semaine

Problèmes et Solutions 2023-2024

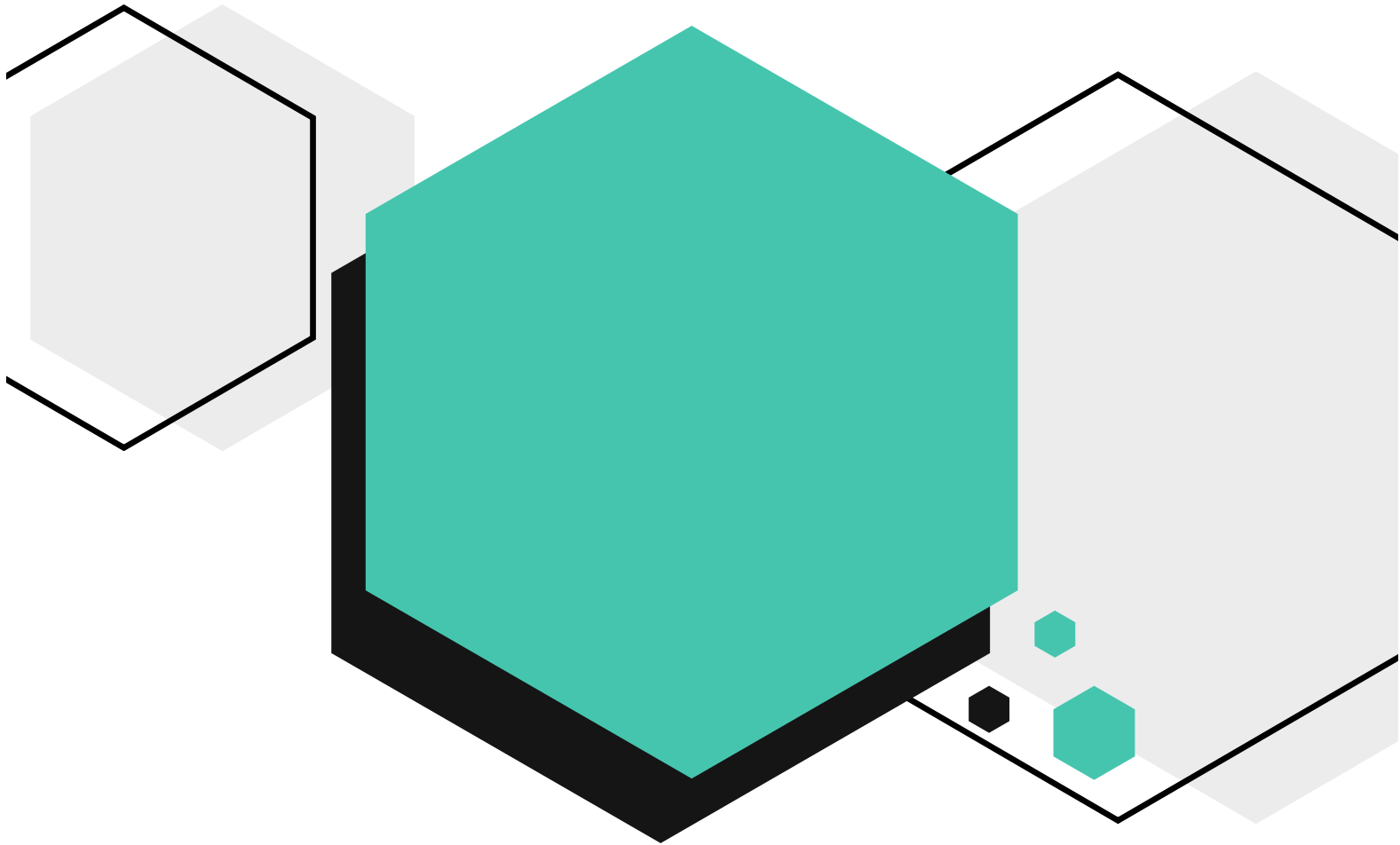

Problème C

7e/8e année



Le CENTRE d'ÉDUCATION
en MATHÉMATIQUES et en INFORMATIQUE
cemc@uwaterloo.ca

Table des Matières

Les problèmes dans ce livret sont organisés par thème.
Un problème peut apparaître dans plusieurs thèmes.
Cliquer sur le nom du thème ci-dessous pour sauter à cette section.

Algèbre (A)

Raisonnement informatiques (C)

Gestion des données (D)

Géométrie et mesure (G)

Sens du nombre (N)

Algèbre (A)

**Amène-moi à la
couverture**



Problème de la semaine

Problème C

Partager des raisins

Jessica a des raisins. Elle donne un tiers de ses raisins à Callista. Elle donne ensuite 4 raisins à Monica. Enfin, elle donne la moitié des raisins qui lui restent à Peter. Ensuite, s'il reste 16 raisins à Jessica, combien de raisins Jessica avait-t-elle au début ?

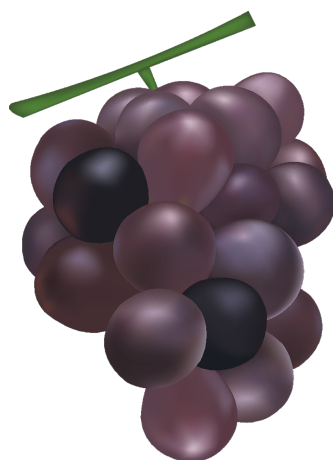

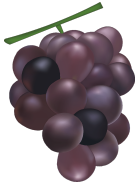

Problem of the Week

Problem C and Solution

Sharing Grapes

Problem

Jessica has some grapes. She gives one-third of her grapes to Callista. She then gives 4 grapes to Monica. Finally, she gives one-half of her remaining grapes to Peter. If Jessica then has 16 grapes left, how many grapes did Jessica begin with?

Solution

Solution 1:

We work backwards from the last piece of information given.

Jessica has 16 grapes left after giving one-half of her remaining grapes to Peter. This means that she had $2 \times 16 = 32$ grapes immediately before giving grapes to Peter.

Immediately before giving grapes to Peter, she gave 4 grapes to Monica, which means that she had $32 + 4 = 36$ grapes immediately before giving 4 grapes to Monica.

Immediately before giving the 4 grapes to Monica, she gave one-third of her grapes to Callista, which would have left her with two-thirds of her original amount.

Since two-thirds of her original amount equals 36 grapes, then one-third equals one half of 36 or $\frac{36}{2} = 18$ grapes.

Thus, she gave 18 grapes to Callista, and so Jessica began with $36 + 18 = 54$ grapes.

Solution 2:

Suppose Jessica started with x grapes.

She gives $\frac{1}{3}x$ grapes to Callista, leaving her with $1 - \frac{1}{3}x = \frac{2}{3}x$ grapes.

She then gives 4 grapes to Monica, leaving her with $\frac{2}{3}x - 4$ grapes.

Finally, she gives away one-half of what she has left to Peter, which means that she keeps one-half of what she has left, and so she keeps $\frac{1}{2}(\frac{2}{3}x - 4)$ grapes.

Simplifying this expression, we obtain $\frac{2}{6}x - \frac{4}{2} = \frac{1}{3}x - 2$ grapes.

Since she has 16 grapes left, then $\frac{1}{3}x - 2 = 16$ and so $\frac{1}{3}x = 18$ or $x = 54$.

Therefore, Jessica began with 54 grapes.



Problème de la semaine

Problème C

Observation céleste

Dans un système solaire éloigné, quatre comètes distinctes: la comète Hypatie, la comète Fibonacci, la comète Lovelace et la comète Euclide, ont simultanément traversé le ciel de la planète Ptolémée en 2023. Sur Ptolémée, on sait que la comète Hypatie se manifeste tous les 3 ans, la comète Fibonacci tous les 6 ans, la comète Lovelace tous les 8 ans et la comète Euclide tous les 15 ans.

En quelle année les quatre comètes traverseront-elles simultanément le ciel de Ptolémée ?

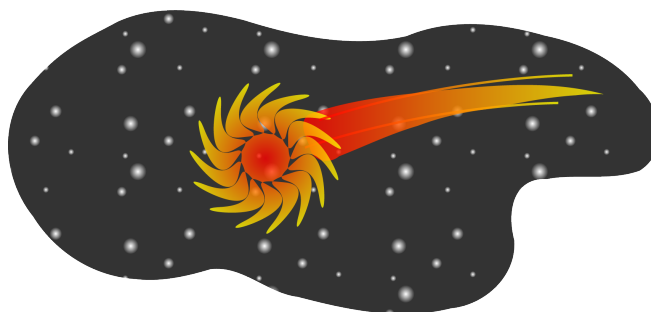

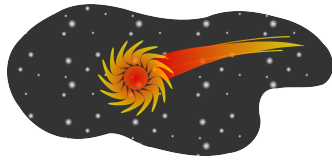

Problem of the Week

Problem C and Solution

Stargazing

Problem

In a distant solar system, four different comets: Hypatia, Fibonacci, Lovelace, and Euclid, passed by the planet Ptolemy in 2023. On Ptolemy, it is known that the Hypatia comet appears every 3 years, the Fibonacci comet appears every 6 years, the Lovelace comet appears every 8 years, and the Euclid comet appears every 15 years.

When is the next year that all four comets will pass by Ptolemy?

Solution

Since the Hypatia comet appears every 3 years, it will pass by Ptolemy in the following numbers of years: 3, 6, 9, 12, 15, 18, 21, 24, 27, 30....

Since the Fibonacci comet appears every 6 years, it will pass by Ptolemy in the following numbers of years: 6, 12, 18, 24, 30,....

Therefore, both the Hypatia and Fibonacci comets will pass by Ptolemy in the following numbers of years: 6, 12, 18, 24, 30,....

This happens because these numbers are *common multiples* of 3 and 6. If we want to determine when all four comets next pass by Ptolemy, we need to find the *least common multiple* (LCM) of 3, 6, 8, and 15. We shall do this in two ways.

Solution 1

The first way to find the LCM is to list the positive multiples of 3, 6, 8, and 15, until we find a common multiple in each list.

Number	Positive Multiples
3	3, 6, 9, 12, 15, 18, 21, ..., 108, 111, 114, 117, 120 , 123, ...
6	6, 12, 18, 24, 30, 36, 42, ..., 96, 102, 108, 114, 120 , 126, ...
8	8, 16, 24, 32, 40, 48, 56, ..., 104, 112, 120 , 128, ...
15	15, 30, 45, 60, 75, 90, 105, 120 , 135, ...

Thus, the LCM of 3, 6, 8, and 15 is 120. Therefore, the next time all four planets will pass by Ptolemy is in 120 years. This will be the year 2143.



Solution 2

The second way to determine the LCM is to rewrite 3, 6, 8, and 15 as a prime or a product of prime numbers. (This is known as *prime factorization*.)

- $3 = 3$
- $6 = 2 \times 3$
- $8 = 2 \times 2 \times 2$
- $15 = 3 \times 5$

The LCM is calculated by determining the greatest number of each prime number in any of the factorizations (here we will have three 2s, one 3, and one 5), and then multiplying these numbers together. This gives $2 \times 2 \times 2 \times 3 \times 5 = 120$. Therefore, the next time all four planets will pass by Ptolemy is in 120 years. This will be the year 2143.

NOTE: The second method is a more efficient way to find the LCM, especially when the numbers are quite large.



Problème de la semaine

Problème C

Étalage de fruits

Jigme a disposé cinq oranges en rangée sur un long plateau. Ensuite, il a placé une pomme dans chaque espace entre deux oranges.

Puis, il a placé une banane dans chaque espace entre deux fruits de la rangée.

Il a ensuite répété cette procédure avec des poires, puis des pêches et enfin avec des fraises.

Détermine le nombre total de fruits dans la rangée.

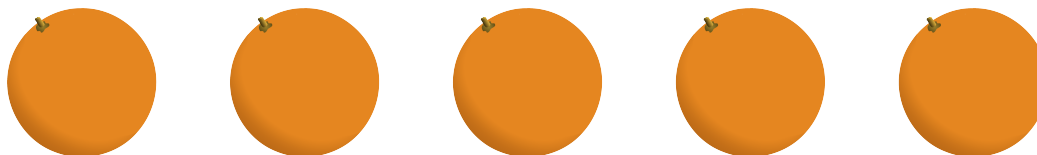



Problem of the Week



Problem C and Solution

Fruit Display

Problem

Jigme placed five oranges in a row on a long plate. He then placed one apple in each of the spaces in the row between two oranges.

Next, he placed one banana in each of the spaces between two fruits already in the row.

He then repeated this procedure with pears, then peaches, and finally with strawberries.

Determine the total number of fruits in the row.

Solution

After placing 5 oranges in the row, there are 4 spaces between the fruits. So Jigme placed 4 apples in the row. At this point, there are $5 + 4 = 9$ fruits in the row.

Since there are now 9 fruits in the row, there are 8 spaces between the fruits. So Jigme placed 8 bananas in the row. At this point, there are $9 + 8 = 17$ fruits in the row.

Since there are now 17 fruits in the row, there are 16 spaces between the fruits. So Jigme placed 16 pears in the row. At this point, there are $17 + 16 = 33$ fruits in the row.

Since there are now 33 fruits in the row, there are 32 spaces between the fruits. So Jigme placed 32 peaches in the row. At this point, there are $33 + 32 = 65$ fruits in the row.

Finally, since there are now 65 fruits in the row, there are 64 spaces between the fruits. So Jigme placed 64 strawberries in the row. At this point, there are $65 + 64 = 129$ fruits in the row.

Thus, there are 129 fruits in the row in total.

EXTENSION:

You may have noticed a pattern in the total number of fruits after each new fruit was added. If Jigme placed fruits in this way using n different fruits, there will be a total of $2^{n+1} + 1$ fruits in the row. Can you see why? Start by looking at the number of spaces between the fruits.



Problème de la semaine

Problème C

Récolte fruitée

Owen, Gabriel et Ariane travaillent comme cueilleurs de fraises dans une ferme locale. Une semaine, Owen a cueilli 135 fraises de plus que Gabriel et Ariane a cueilli 110 fraises de plus qu'Owen. En tout cette semaine, Owen, Gabriel et Ariane ont cueilli 2000 fraises.

Détermine le nombre de fraises que chaque personne a cueilli.





Problem of the Week

Problem C and Solution

Berry Picking

Problem

Owen, Gabriel, and Ariane work as strawberry pickers at a local farm. One week Owen picked 135 more strawberries than Gabriel, and Ariane picked 110 more strawberries than Owen. In total that week Owen, Gabriel, and Ariane picked 2000 strawberries.

Determine the number of strawberries that each person picked.

Solution

Solution 1

Let g be the number of strawberries that Gabriel picked. It follows that Owen picked $(g + 135)$ strawberries and Ariane picked $(g + 135 + 110)$ strawberries. Since they picked 2000 strawberries in total, we can write and solve the following equation:

$$g + (g + 135) + (g + 135 + 110) = 2000$$

$$g + (g + 135) + (g + 245) = 2000$$

$$3g + 380 = 2000$$

$$3g = 1620$$

$$g = 540$$

So, $g + 135 = 675$ and $g + 135 + 110 = 785$.

Thus, Gabriel picked 540 strawberries, Owen picked 675 strawberries, and Ariane picked 785 strawberries.

Solution 2

If Owen had picked 135 fewer strawberries, and Ariane had picked $135 + 110 = 245$ fewer strawberries, then each would have picked the same number of strawberries as Gabriel. In that case, each person would have picked $\frac{1}{3}$ of $(2000 - 135 - 245)$, which is $\frac{1}{3} \times 1620 = 540$ strawberries.

Thus, Gabriel picked 540 strawberries. Then Owen picked $540 + 135 = 675$ strawberries and Ariane picked $540 + 245 = 785$ strawberries.



Problème de la semaine

Problème C

Pièces en folie

Jean a donné à Karyna un sac de pièces de monnaie contenant uniquement des pièces de 5 cents et de 10 cents. La valeur totale des pièces dans le sac était de 11 \$ et il y avait 16 pièces de 5 cents de plus que de pièces de 10 cents dans le sac.

Combien y avait-il de pièces au total dans le sac ?



NOTE : Au Canada, 100 cents équivalent 1 \$.



Problem of the Week

Problem C and Solution

Gimme Some Change

Problem

Jean gave Karyna a bag of coins containing only nickels (5 cent coins) and dimes (10 cent coins). The total value of all the coins in the bag was \$11 and there were 16 more nickels than dimes in the bag.

How many coins in total were in the bag?

NOTE: In Canada, 100 cents is equal to \$1.

Solution

Solution 1

In this solution, we will solve the problem without using algebra.

The bag had 16 more nickels than dimes. These 16 nickels are worth $16 \times 5 = 80$ cents, or \$0.80. The remaining $\$11.00 - \$0.80 = \$10.20$ would be made up using an equal number of nickels and dimes. Each nickel-dime pair is worth 15 cents, or \$0.15. By dividing \$10.20 by \$0.15 we determine the number of nickel-dime pairs that are required to make \$10.20. Since $\$10.20 \div \$0.15 = 68$, we need 68 nickel-dime pairs. That is, we need 68 nickels and 68 dimes to make \$10.20. But there were 16 more nickels in the bag. Therefore, there were a total of $68 + 68 + 16 = 152$ coins in the bag.

Solution 2

In this solution, we will solve the problem using algebra.

Let d represent the number of dimes. Since there were 16 more nickels than dimes in the bag, then there were $(d + 16)$ nickels in the bag. Since each dime is worth 10 cents, the value of d dimes is $10d$ cents.

Since each nickel is worth 5 cents, the value of $(d + 16)$ nickels is $5(d + 16)$ cents. The bag contains a total value of \$11 or 1100 cents. Therefore,

$$\text{Value of Dimes (in cents)} + \text{Value of Nickels (in cents)} = \text{Total Value (in cents)}$$

$$10d + 5(d + 16) = 1100$$

$$10d + 5d + 80 = 1100$$

$$15d = 1100 - 80$$

$$15d = 1020$$

$$d = 68$$

$$d + 16 = 84$$

Therefore, there were 68 dimes and 84 nickels for a total of $68 + 84 = 152$ coins in the bag.



Problème de la semaine

Problème C

Chevauchement 1

Omar dessine le carré $ABCD$ dont les côtés mesurent 4 cm. Jaime dessine ensuite le triangle AED sur le carré $ABCD$ de manière que:

- les côtés AE et DE touchent BC en F et G respectivement,
- FG mesure 3 cm et
- l'aire du triangle AED est le double de l'aire du carré $ABCD$.

Détermine l'aire du triangle FEG .

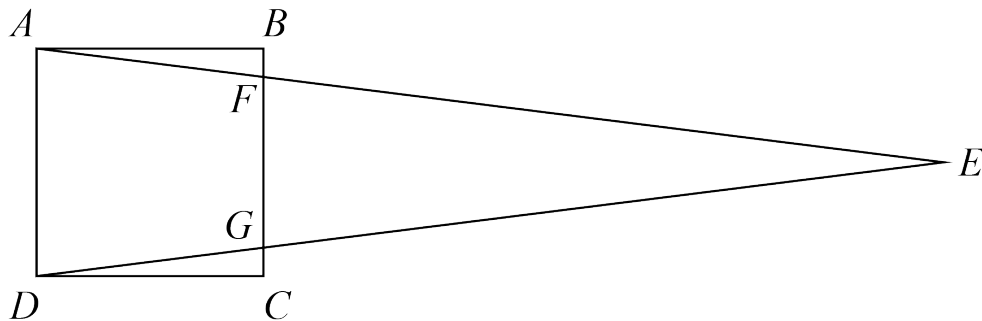

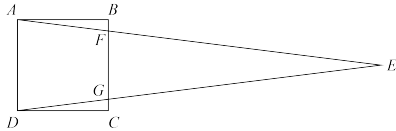

Problem of the Week

Problem C and Solution

Overlapping Shapes 1

Problem

Omar draws square $ABCD$ with side length 4 cm. Jaime then draws $\triangle AED$ on top of square $ABCD$ so that

- sides AE and DE meet BC at F and G , respectively,
- FG is 3 cm, and
- the area of $\triangle AED$ is twice the area of square $ABCD$.

Determine the area of $\triangle FEG$.

Solution

Solution 1

In the first solution we will find the area of square $ABCD$, the area of $\triangle AED$, the area of trapezoid $AFGD$, and then use these to calculate the area of $\triangle FEG$.

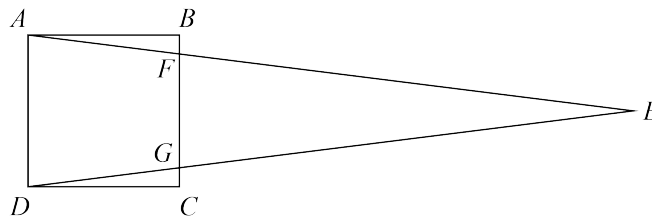

The area of square $ABCD$ is $4 \times 4 = 16 \text{ cm}^2$. Since the area of $\triangle AED$ is twice the area of square $ABCD$, it follows that the area of $\triangle AED$ is $2 \times 16 = 32 \text{ cm}^2$.

Recall that to find the area of a trapezoid, we multiply the sum of the lengths of the two parallel sides by the height, and divide the product by 2. In trapezoid $AFGD$, the two parallel sides are AD and FG , and the height is the width of square $ABCD$, namely AB .

$$\begin{aligned}\text{Area of trapezoid } AFGD &= (AD + FG) \times AB \div 2 \\ &= (4 + 3) \times 4 \div 2 \\ &= 7 \times 4 \div 2 \\ &= 14 \text{ cm}^2\end{aligned}$$

The area of $\triangle FEG$ is equal to the area of $\triangle AED$ minus the area of trapezoid $AFGD$. Thus, the area of $\triangle FEG$ is $32 - 14 = 18 \text{ cm}^2$.



Solution 2

We construct an altitude of $\triangle AED$ from E , intersecting AD at P and BC at Q . Since $ABCD$ is a square, we know that AD is parallel to BC . Therefore, since PE is perpendicular to AD , QE is perpendicular to FG and thus an altitude of $\triangle FEG$. In this solution we will find the height of $\triangle FEG$, that is, the length of QE , and then use this to calculate the area of $\triangle FEG$.

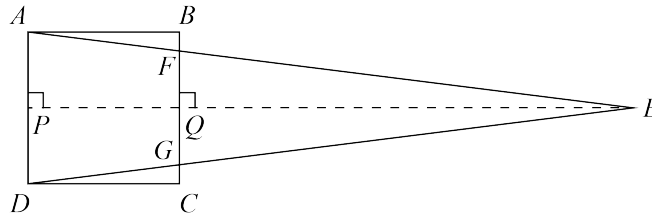

The area of square $ABCD$ is $4 \times 4 = 16 \text{ cm}^2$. Since the area of $\triangle AED$ is twice the area of square $ABCD$, it follows that the area of $\triangle AED$ is $2 \times 16 = 32 \text{ cm}^2$.

We also know that

$$\begin{aligned}\text{Area } \triangle AED &= AD \times PE \div 2 \\ 32 &= 4 \times PE \div 2 \\ 32 &= 2 \times PE \\ PE &= 32 \div 2 \\ &= 16 \text{ cm}\end{aligned}$$

Since $\angle APQ = 90^\circ$, we know that $ABQP$ is a rectangle, and so $PQ = AB = 4$ cm. We also know that $PE = PQ + QE$. Since $PE = 16$ cm and $PQ = 4$ cm, it follows that $QE = PE - PQ = 16 - 4 = 12$ cm. We can then calculate the area of $\triangle FEG$.

$$\begin{aligned}\text{Area } \triangle FEG &= FG \times QE \div 2 \\ &= 3 \times 12 \div 2 \\ &= 18 \text{ cm}^2\end{aligned}$$

Therefore, the area of $\triangle FEG$ is 18 cm^2 .



Problème de la semaine

Problème C

Expressions exponentielles

Voici deux expressions :

$$\text{Expression } A: 72 \times 7^x$$

$$\text{Expression } B: 441 \times 2^y$$

Etant donné que x et y sont des nombres entiers strictement positifs, trouve tous les couples (x, y) tels que la valeur de l'expression A soit égale à celle de l'expression B .

$$A=B$$



$A=B$

Problem of the Week Problem C and Solution Exponential Expressions

Problem

We are given two expressions:

$$\text{Expression } A: 72 \times 7^x$$

$$\text{Expression } B: 441 \times 2^y$$

Given that x and y are positive integers, find all ordered pairs (x, y) so that the value of Expression A is equal to the value of Expression B .

Solution

Solution 1

We write each expression as the product of prime numbers.

$$\text{Expression } A = (2^3)(3^2)(7^x) \text{ and Expression } B = (3^2)(7^2)(2^y).$$

Since x and y are each positive integers and the expressions are equal in value, then the corresponding exponents for each prime number must be equal.

Therefore, $x = 2$ and $y = 3$ is the only integer solution.

Thus, the only ordered pair is $(2, 3)$.

Solution 2

Setting the two expressions equal to each other, we have

$$72 \times 7^x = 441 \times 2^y$$

Dividing both sides by 9, we have

$$8 \times 7^x = 49 \times 2^y$$

Expressing each side of the equation as the product of prime numbers, we have

$$2^3 \times 7^x = 7^2 \times 2^y$$

Since x and y are each positive integers and the expressions are equal in value, then the corresponding exponents for each prime number must be equal.

Therefore, $x = 2$ and $y = 3$ is the only integer solution.

Thus, the only ordered pair is $(2, 3)$.



Raisonnement informatiques (C)

Amène-moi à la
couverture



Problème de la semaine

Problème C

Le ballet des nénuphars

Dans un jeu vidéo, une grenouille saute le long d'une rangée de nénuphars. Il y a dix nénuphars dans la rangée, numérotés de 1 à 10, en commençant par la gauche.



Depuis n'importe quel nénuphar, la grenouille peut sauter soit deux nénuphars à droite, soit trois nénuphars à gauche, tant qu'elle atterrit sur l'un des dix nénuphars.

Par exemple, depuis le nénuphar 8, la grenouille peut sauter soit trois nénuphars à gauche pour atteindre le nénuphar 5, soit deux nénuphars à droite pour atteindre le nénuphar 10. Cependant, depuis le nénuphar 2, la grenouille peut seulement sauter deux nénuphars à droite pour atteindre le nénuphar 4 car le fait de sauter trois nénuphars à gauche la ferait passer au delà du nénuphar 1 et il n'y aurait donc pas de nénuphar sur lequel atterrir.

Si la grenouille commence sur le nénuphar 1 et visite chaque nénuphar exactement une fois, quel est le numéro du dernier nénuphar sur lequel elle atterrit ?

Tu n'arrives pas à imprimer cette page? Essaie notre [feuille de travail interactive](#).

Ce problème s'inspire d'un autre problème qui figurait dans un des concours précédents du [défi informatique Beaver](#).



Problem of the Week

Problem C and Solution

Just Keep Hopping

Problem

In a computer game, a frog jumps along a row of lily pads. There are ten lily pads in the row, numbered from 1 to 10 starting on the left.



From any lily pad the frog can jump either two lily pads right or three lily pads left, as long as it lands on one of the ten lily pads.

For example from lily pad 8, the frog can jump either three lily pads left to pad 5, or two lily pads right to pad 10. However, from lily pad 2, the frog can only jump two lily pads right to pad 4 because jumping three lily pads left would take it past pad 1 so there would be no lily pad to land on.

If the frog starts on lily pad 1 and visits every lily pad exactly once, what is the number on the last lily pad it lands on?

Not printing this page? You can use our [interactive worksheet](#).

This problem was inspired by a past [Beaver Computing Challenge \(BCC\)](#) problem.

Solution

Starting on lily pad 1, the frog can only jump two lily pads right to pad 3. From there, it can only jump two lily pads right to pad 5. Lily pads that have been visited are shown in grey.



From lily pad 5 the frog can either jump three lily pads left to pad 2, or two lily pads right to pad 7. However, the only way to visit pad 2 is from pad 5, and since the frog visits each lily pad exactly once, it can't come back to pad 5 later. So the frog must jump to pad 2 now.

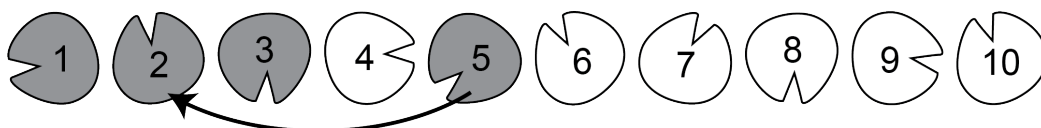



From lily pad 2 the frog can only jump two lily pads right to pad 4. From there, it can only jump two lily pads right to pad 6, from there it can only jump two lily pads right to pad 8, and from there it can only jump two lily pads right to pad 10.

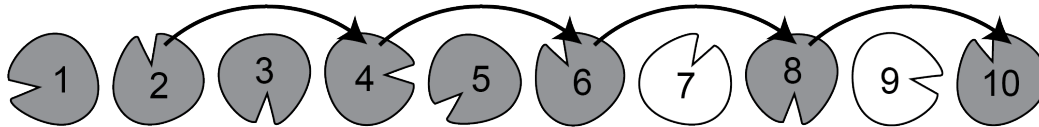

From lily pad 10 the the frog can only jump three lily pads left to pad 7. From there, it can only jump two lily pads right to pad 9.

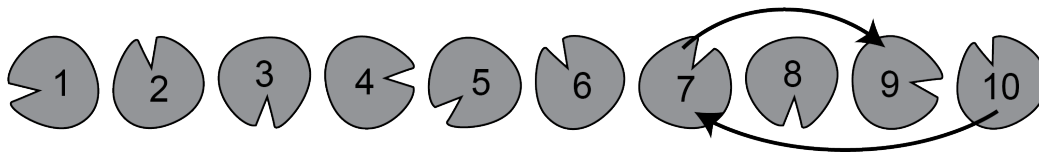

At this point all of the lily pads have been visited exactly once. Therefore, the last lily pad that the frog lands on is pad 9.



Problème de la semaine

Problème C

Labyrinthe de maïs

Baljit et Harinder se rendent à une ferme locale pour parcourir un labyrinthe de maïs. La carte du labyrinthe est présentée dans la figure ci-dessous.

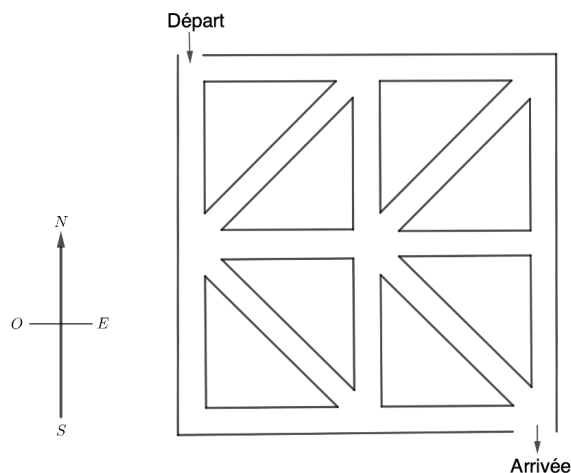

Le jour de leur visite, la ferme impose certaines règles: ils ne peuvent se déplacer qu'en direction du sud, de l'est ou du sud-est le long des chemins. Compte tenu de ces restrictions, combien de parcours différents peuvent-ils emprunter pour aller du point de départ jusqu'à l'arrivée ?

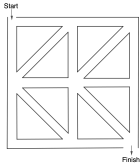

Problem of the Week

Problem C and Solution

Corn Maze

Problem

Baljit and Harinder go to a local farm to do a corn maze. The map of the corn maze is given. On the day they arrive, the farm has the restrictions that they can only travel south, east, or southeast along a path. Using these restrictions, how many different routes can they take from Start to Finish?

Solution

We can solve this problem by tracing out different routes and counting how many we find. We will set up a systematic approach to do so, to ensure that we do not miss any routes.

We begin by labelling the Start with the letter S and the Finish with the letter F . We label the other seven intersections in the maze as A , B , C , D , E , G , and H , as shown.

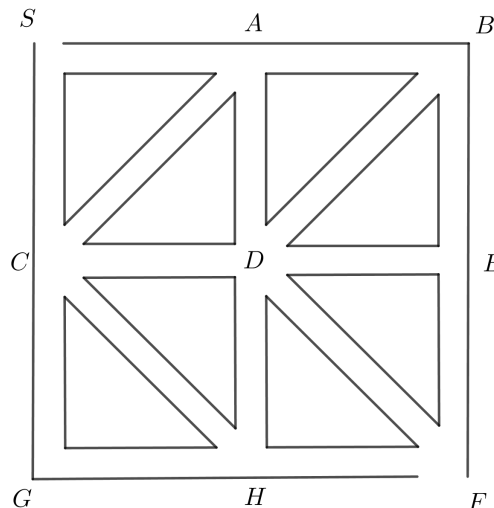

Starting at S , Baljit and Harinder can only travel next to A or C .

Case 1: Baljit and Harinder travel from S to A .

Since Baljit and Harinder can only travel east, south, or southeast along a path, they have only two choices for where to go next: B or D .

- If Baljit and Harinder travel to B , then since they can only travel east, south, or southeast, they must go to E next, followed by F . Therefore, one route from S to F is from S to A to B to E to F .
- If Baljit and Harinder travel to D , then since they can only travel east, south, or southeast, they can go to E , F , or H next.



- If they travel from D to E , they must then go to F . Therefore, one route from S to F is from S to A to D to E to F .
- If they travel from D to F , we have found another route. Therefore, one route from S to F is from S to A to D to F .
- If they travel from D to H , they must then go to F . Therefore, one route from S to F is from S to A to D to H to F .

In total, there are four routes from S to F in which Baljit and Harinder first travel from S to A .

Case 2: Baljit and Harinder travel from S to C .

Since Baljit and Harinder can travel east, south, or southeast along a path, they have three choices for where to go next: D , H , or G .

- If they travel from C to D , they again have three choices for where to go next: E , F , or H .
 - If they travel from D to E , they must then go to F . Therefore, one route from S to F is from S to C to D to E to F .
 - If they travel from D to F , we have found another route. Therefore, one route from S to F is from S to C to D to F .
 - If they travel from D to H , they must then go to F . Therefore, one route from S to F is from S to C to D to H to F .
- If they travel from C to H , from H they must go to F . Therefore, another route from S to F is from S to C to H to F .
- If they travel from C to G , they must then go to H and then to F . Another route from S to F is from S to C to G to H to F .

In total, there are five routes from S to F in which Baljit and Harinder first travel from S to C .

Therefore, there are a total of $4 + 5 = 9$ different routes that Baljit and Harinder can take from Start to Finish.



Problème de la semaine

Problème C

Année bissextile 1

La plupart des gens croient qu'une année compte 365 jours, mais en réalité, elle en compte légèrement plus. Pour ajuster ce surplus de temps, on a recours aux années bissextiles. Ces dernières sont des années qui contiennent un jour de plus.

On peut utiliser l'organigramme ci-contre pour déterminer si une année donnée est bissextile ou non. D'après l'organigramme :

- l'année 2018 n'était **pas** une année bissextile car 2018 n'est pas divisible par 4.
- l'année 2016 était une année bissextile car 2016 est divisible par 4, mais n'est pas divisible par 100.
- l'année 2100 ne sera **pas** une année bissextile car 2100 est divisible par 4 et par 100, mais n'est pas divisible par 400.
- l'année 2000 était une année bissextile car 2000 est divisible par 4, par 100 et par 400.

Combien y a-t-il d'années bissextiles entre les années 2000 et 2400 inclusivement ?

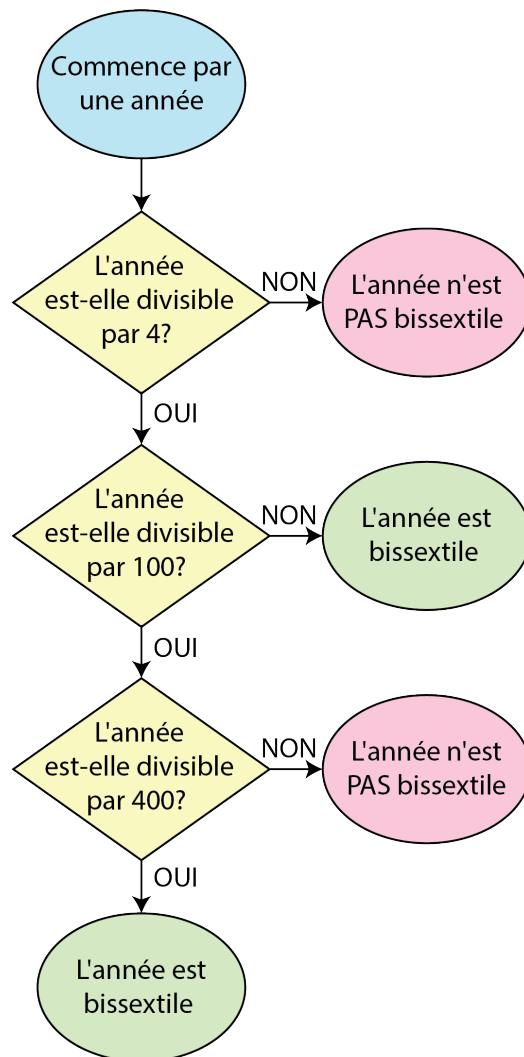



Problem of the Week

Problem C and Solution

A Small Leap

Problem

Most people think of a year as 365 days, however it is actually slightly more than 365 days. To account for this extra time we use leap years, which are years containing one extra day.

The flowchart shown can be used to determine whether or not a given year is a leap year. Using the flowchart, we can conclude the following:

- 2018 was **not** a leap year because 2018 is not divisible by 4.
- 2016 was a leap year because 2016 is divisible by 4, but not 100.
- 2100 will **not** be a leap year because 2100 is divisible by 4 and 100, but not 400.
- 2000 was a leap year because 2000 is divisible by 4, 100, and 400.

How many leap years are there between the years 2000 and 2400, inclusive?

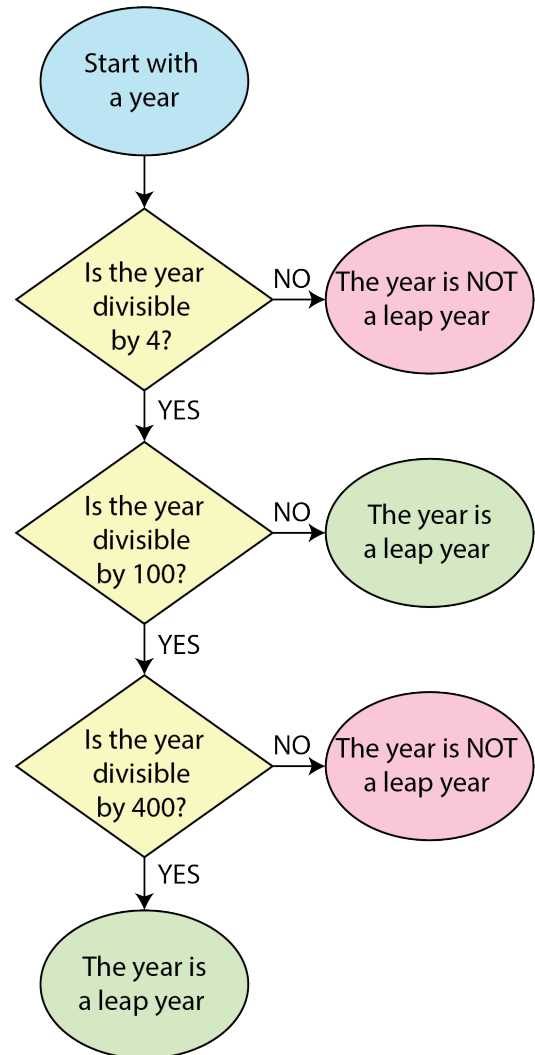



Solution

From the flowchart we can determine that leap years are either

- multiples of 4 that are not also multiples of 100, or
- multiples of 4, 100, and 400.

Note that we can simplify the second case to just multiples of 400, since any multiple of 400 will also be a multiple of 4 and 100.

First we notice that 2000 and 2400 are both multiples of 400, so they are both leap years. In fact, they are the only multiples of 400 between 2000 and 2400, inclusive.

Next we count the multiples of 4 between 2000 and 2400, inclusive. Writing out some of the first few multiples of 4 gives: 2000, 2004, 2008, 2012, . . .

We will look at the 400 numbers from 2000 to 2399 and ignore 2400 for the moment since we already know it's a leap year. Since 2000 is a multiple of 4 and every fourth number after that is also a multiple of 4, it follows that $\frac{1}{4}$ of the 400 numbers from 2000 to 2399 will be multiples of 4. Thus, there are $\frac{1}{4} \times 400 = 100$ multiples of 4 between 2000 and 2399, inclusive.

However, we have included the multiples of 100, so we need to subtract these. These are 2000, 2100, 2200, and 2300. Thus there are $100 - 4 = 96$ multiples of 4 between 2000 and 2399, inclusive, that are not also multiples of 100.

Thus, in total, there are $2 + 96 = 98$ leap years between 2000 and 2400, inclusive.



Problème de la semaine

Problème C

Bols empilables

Alice possède plusieurs bols de tailles différentes. Elle aime empiler ses bols à l'envers. Un bol peut être *empilé sur* un autre bol si le plus petit bol peut être complètement entouré par le plus grand. C'est-à-dire que le plus grand bol peut complètement cacher le plus petit.

Dans l'exemple ci-dessous, on peut empiler un bol d'une largeur de 10 cm et d'une hauteur de 10 cm sur un bol d'une largeur de 5 cm et d'une hauteur de 5 cm. De même, on peut empiler un bol d'une largeur de 20 cm et d'une hauteur de 20 cm sur ces deux bols. On obtient alors une seule pile de bols.

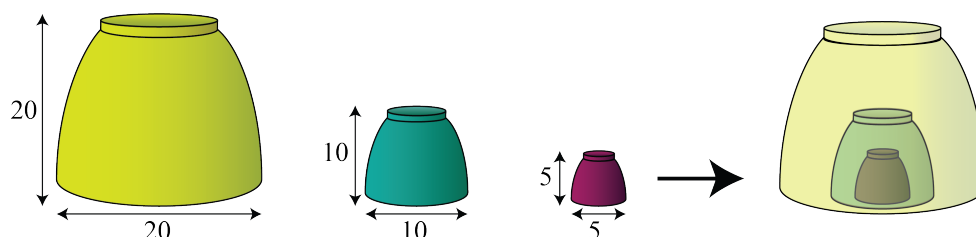

Cependant, on ne peut empiler un bol d'une largeur de 20 cm et d'une hauteur de 20 cm sur un bol d'une largeur de 25 cm et d'une hauteur de 15 cm. De même, on ne peut empiler un bol d'une largeur de 25 cm et d'une hauteur de 15 cm sur un bol d'une largeur de 20 cm et d'une hauteur de 20 cm.

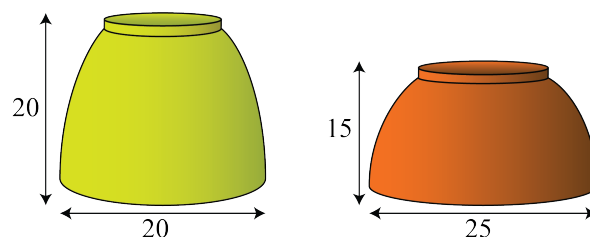

Alice commence à empiler les bols dans la figure ci-dessous. Quel est le nombre minimal de piles qu'elle peut créer ?

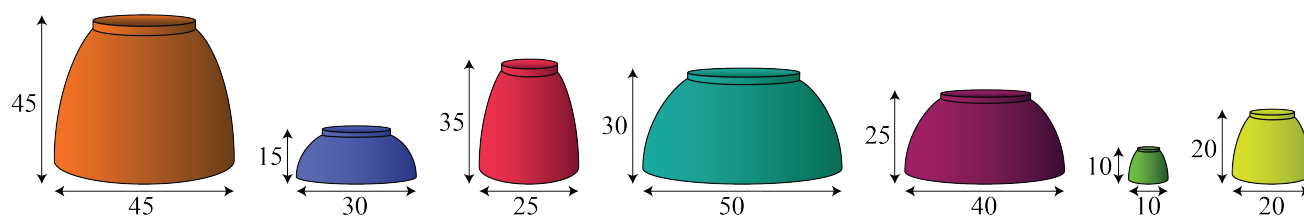

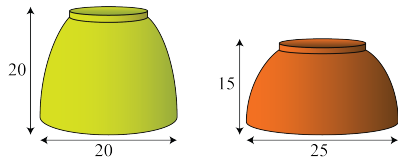

Problem of the Week

Problem C and Solution

Stacking Bowls

Problem

Alice has a set of bowls of various sizes. She likes stacking her bowls upside down. A bowl can be *stacked over* another bowl if the smaller bowl can be completely enclosed by the larger bowl. This means the larger bowl can completely hide the smaller bowl.

For the example below, a bowl with a width of 10 cm and height 10 cm can stack over a bowl with a width of 5 cm and a height of 5 cm. In turn they can be stacked over by a bowl with a width of 20 cm and a height of 20 cm. This gives a single stack.

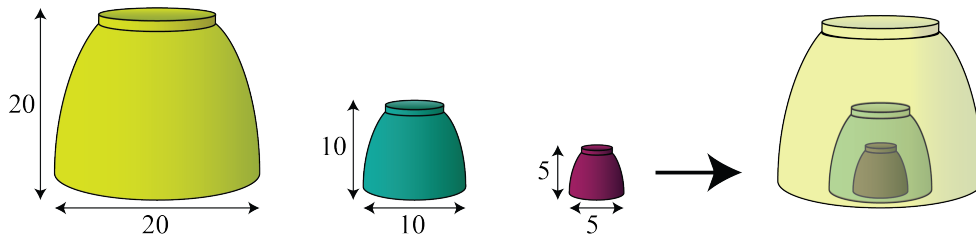

On the other hand, a bowl with a width of 20 cm and a height of 20 cm cannot be stacked over a bowl of a width of 25 cm and a height of 15 cm. Also, a bowl with a width of 25 cm and a height of 15 cm cannot be stacked over a bowl of a width of 20 cm and a height of 20 cm.

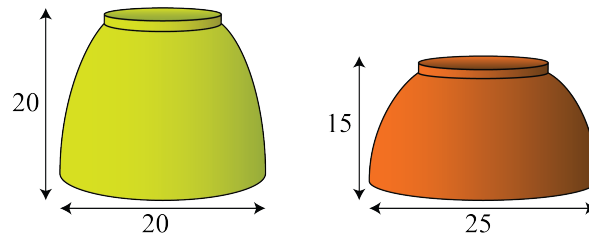

Alice has the following set of bowls and starts stacking them. What is the fewest number of stacks that Alice can have?

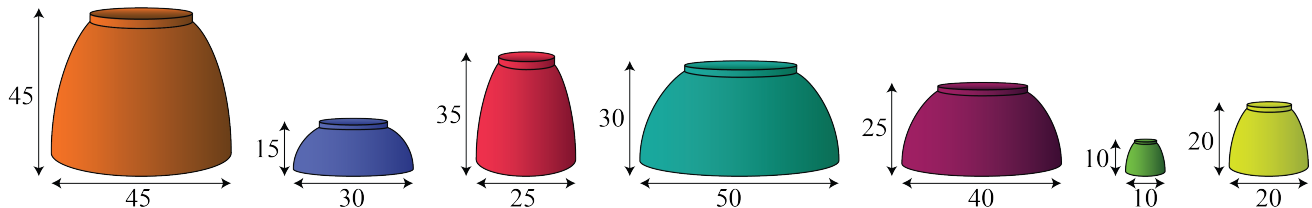



Solution

We note that the bowl with a width of 45 cm and a height of 45 cm cannot be stacked over a bowl of a width of 50 cm and a height of 30 cm. We also note that we are not able to stack these two bowls the other way either. Therefore, we cannot have a single stack. Thus, if we can find a solution with two stacks then we will find the fewest number of stacks is two.

Here is a solution with two possible stacks. The four bowls in the first row can be stacked and the three bowls in the bottom row can also be stacked.

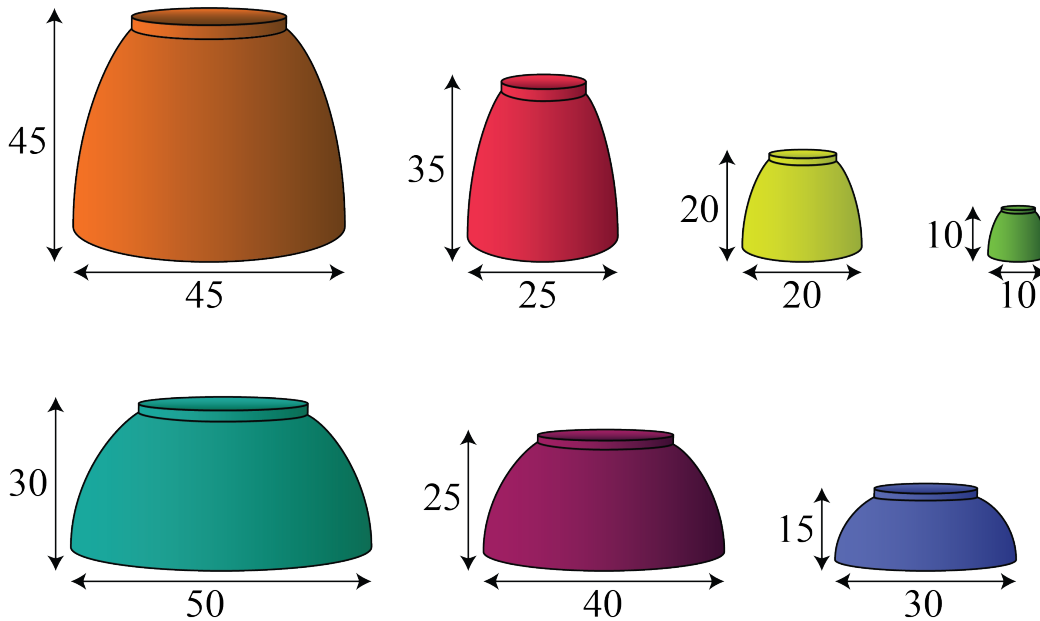

Therefore, the fewest number of stacks is 2.



Problème de la semaine

Problème C

À vos sièges 1

Douze personnes sont assises autour d'une table ronde, chacune tenant une carte sur laquelle figure un nombre entier différent de 1 à 12. Pour toute paire de personnes assises côte à côte, la différence positive entre les nombres entiers figurant sur leurs cartes est inférieure ou égale à 2. Les personnes dont les entiers sont 1, 3, a et b sont assises comme dans la figure ci-dessous.

Quelle est la valeur de $a + b$?

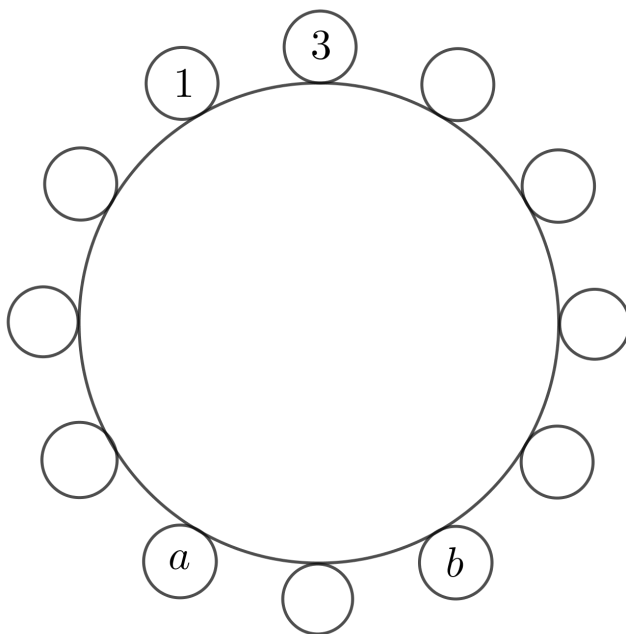

REMARQUE: La *différence positive* entre deux nombres est obtenue en soustrayant le plus petit nombre du plus grand nombre.



Problem of the Week

Problem C and Solution

Take a Seat 1

Problem

Twelve people are seated around a circular table. They each hold a card with a different integer from 1 to 12 on it. For any two people sitting beside each other, the positive difference between the integers on their cards is no more than 2. The people with integers 1, 3, a , and b are seated as shown.

What is the value of $a + b$?

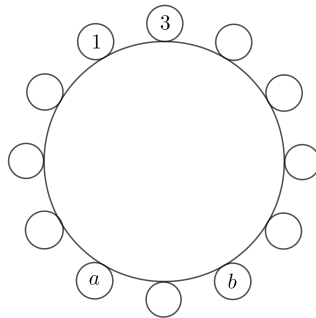

Solution

Because two integers that are beside each other must have a positive difference of at most 2, then the possible neighbours of 1 are 2 and 3. Since 1 has exactly two neighbours, then 1 must be between 2 and 3.

Next, consider 2. Its possible neighbours are 1, 3, and 4. The number 2 is already a neighbour of 1 and cannot be a neighbour of 3 (since 3 is on the other side of 1). Therefore, 2 is between 1 and 4. This allows us to update the diagram as shown.

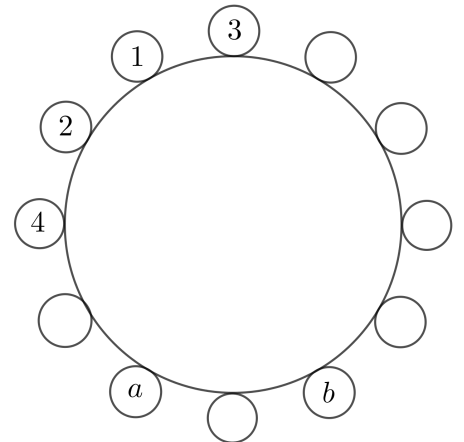

Continuing in this way, the possible neighbours of 3 are 1, 2, 4, and 5. The number 1 is already beside 3, and the numbers 2 and 4 cannot be beside 3. So 5 must be beside 3.

The possible neighbours of 4 are 2, 3, 5, and 6. The number 2 is already beside 4. Numbers 3 and 5 cannot be beside 4. So 6 must be beside 4.

Similarly, we know 7 will be beside 5 and 8 will be beside 6. Thus, $a = 8$. Continuing this way, we know 9 is beside 7, 10 is beside 8, 11 is beside 9, and 12 is beside 10. Thus, $b = 12$. The completed circle is shown.

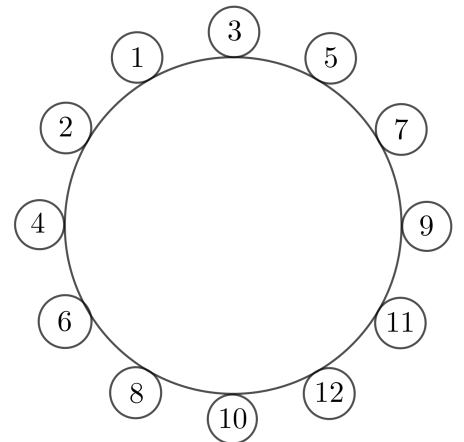

Therefore, $a + b = 8 + 12 = 20$.



Gestion des données (D)

**Amène-moi à la
couverture**



Problème de la semaine

Problème C

Roulettes de carrés parfaits

Esa a conçu un jeu pour une foire mathématique en utilisant deux roulettes. La première roulette est divisée en quatre sections égales qui portent les nombres 1, 3, 4 et 5. La seconde est divisée en cinq sections égales qui portent les nombres 1, 3, 5, 9 et 12.

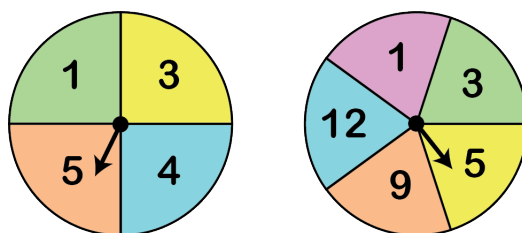

Pour participer, chaque joueur fait tourner les deux roulettes une fois et multiplie les deux nombres obtenus. Si le produit est un carré parfait, le joueur remporte la manche. Quelle est la probabilité de gagner à ce jeu ?

REMARQUE : Le carré d'un entier est un *carré parfait*. Par exemple, le nombre 25 est un carré parfait puisqu'il peut s'écrire 5^2 ou 5×5 .

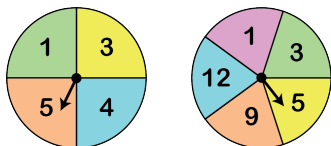

Problem of the Week

Problem C and Solution

Spin to Win

Problem

Esa has created a game for his math fair using two spinners. One spinner is divided into four equal sections labeled 1, 3, 4, and 5. The other spinner is divided into five equal sections labeled 1, 3, 5, 9, and 12. To play the game, a player spins each spinner once and then multiplies the two numbers the spinners land on. If this product is a perfect square, the player wins. What is the probability of winning the game?

NOTE: A square of any integer is called a *perfect square*. For example, the number 25 is a perfect square since it can be expressed as 5^2 or 5×5 .

Solution

In order to determine the probability, we must determine the number of ways to obtain a perfect square and divide it by the total number of possible combinations of spins. To do so, we will create a table where the rows show the possible results for Spinner 1, the spinner with four sections, the columns show the possible results for Spinner 2, the spinner with five sections, and each cell in the body of the table gives the product of the numbers on the corresponding spinners.

		Spinner 2				
		1	3	5	9	12
Spinner 1	1	1	3	5	9	12
	3	3	9	15	27	36
	4	4	12	20	36	48
	5	5	15	25	45	60

From the table, we see that there are 20 possible combinations of spins. Of these, the following result in products that are perfect squares:

- The number 1 is a perfect square ($1 = 1 \times 1$), and it occurs one time.
- The number 4 is a perfect square ($4 = 2 \times 2$), and it occurs one time.
- The number 9 is a perfect square ($9 = 3 \times 3$), and it occurs two times.
- The number 25 is a perfect square ($25 = 5 \times 5$), and it occurs one time.
- The number 36 is a perfect square ($36 = 6 \times 6$), and it occurs two times.

Thus, 7 of the 20 products are perfect squares. Therefore, the probability of winning the game is $\frac{7}{20}$, or 35%.

EXTENSION: A game is considered *fair* if the probability of winning is 50%. Can you modify this game so that it is fair?



Géométrie et mesure (G)

**Amène-moi à la
couverture**



Problème de la semaine

Problème C

L'ours encadré

Pat a quatre morceaux de bois rectangulaires, chacun mesurant 30 cm de long et 3 cm de large. Elle dispose les quatre morceaux de bois de manière à former le cadre autour d'une image d'un ours en peluche, comme dans la figure ci-dessous.

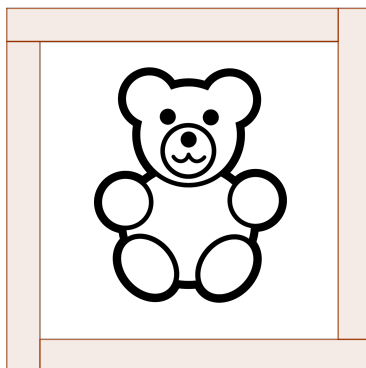

Détermine l'aire de la région encadrée par le cadre en bois.

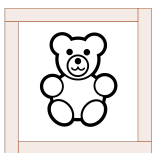

Problem of the Week

Problem C and Solution

Teddy Was Framed

Problem

Pat has four rectangular pieces of wood, each 30 cm long and 3 cm wide. She arranges the four pieces of wood to form the border of a picture frame for a picture of a teddy bear, as shown.

Determine the area of the region enclosed by the wooden frame.

Solution

Solution 1

The region enclosed by the wooden frame is a square with side length $30 - 3 = 27$ cm.

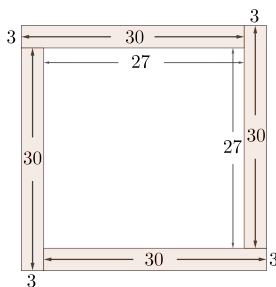

Thus, the area of the region enclosed by the frame is equal to $27 \times 27 = 729$ cm².

Solution 2

The outer perimeter of the frame forms a square with side length $30 + 3 = 33$ cm.

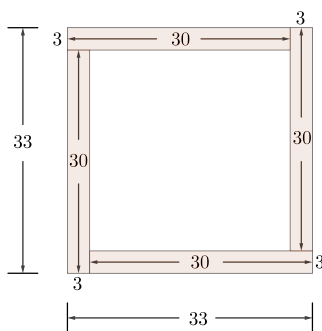

The area of the outer square is therefore $33 \times 33 = 1089$ cm².

The area of the region enclosed by the wooden frame is equal to the area of the outer square minus the areas of the four wooden rectangles.

Each wooden rectangle has area $30 \times 3 = 90$ cm².

Therefore, the area of the region enclosed by the frame is equal to $1089 - 4 \times 90 = 729$ cm².



Problème de la semaine

Problème C

Croisement triangulaire

Le triangle ABC et le triangle PQR sont des triangles équilatéraux dont les sommets B et P sont situés sur le segment de droite MN . Les triangles se coupent en deux points, X et Y , comme dans la figure ci-dessous.

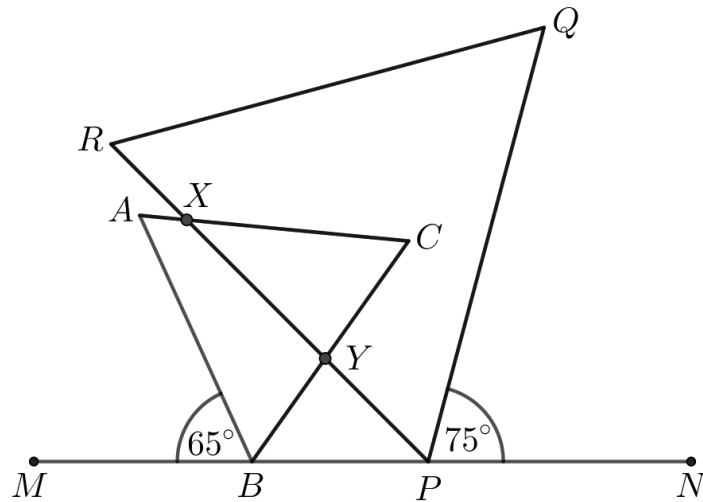

Si $\angle NPQ = 75^\circ$ et $\angle MBA = 65^\circ$, détermine la mesure de l'angle CXY .



Problem of the Week

Problem C and Solution

Intersecting Triangles

Problem

$\triangle ABC$ and $\triangle PQR$ are equilateral triangles with vertices B and P on line segment MN . The triangles intersect at two points, X and Y , as shown.

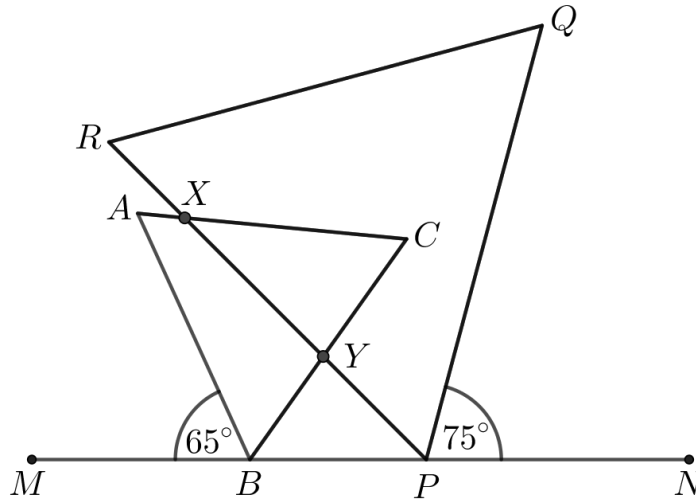

If $\angle NPQ = 75^\circ$ and $\angle MBA = 65^\circ$, determine the measure of $\angle CXY$.

Solution

In any equilateral triangle, all sides are equal in length and each angle measures 60° .

Since $\triangle ABC$ and $\triangle PQR$ are equilateral,
 $\angle ABC = \angle ACB = \angle CAB = \angle QPR = \angle PRQ = \angle RQP = 60^\circ$.

Since the angles in a straight line sum to 180° , we have
 $180^\circ = \angle MBA + \angle ABC + \angle YBP = 65^\circ + 60^\circ + \angle YBP$.
Rearranging, we have $\angle YBP = 180^\circ - 65^\circ - 60^\circ = 55^\circ$.

Similarly, since angles in a straight line sum to 180° , we have
 $180^\circ = \angle NPQ + \angle QPR + \angle YPB = 75^\circ + 60^\circ + \angle YPB$.
Rearranging, we have $\angle YPB = 180^\circ - 75^\circ - 60^\circ = 45^\circ$.

Since the angles in a triangle sum to 180° , in $\triangle BYP$ we have
 $\angle YPB + \angle YBP + \angle BYP = 180^\circ$, and so $45^\circ + 55^\circ + \angle BYP = 180^\circ$.
Rearranging, we have $\angle BYP = 180^\circ - 45^\circ - 55^\circ = 80^\circ$.

When two lines intersect, vertically opposite angles are equal. Since $\angle XYC$ and $\angle BYP$ are vertically opposite angles, we have $\angle XYC = \angle BYP = 80^\circ$.

Again, since angles in a triangle sum to 180° , in $\triangle XYC$ we have
 $\angle XYC + \angle XCY + \angle CXY = 180^\circ$. We have already found that $\angle XYC = 80^\circ$, and since
 $\angle XCY = \angle ACB$, we have $\angle XCY = 60^\circ$. So, $\angle XYC + \angle XCY + \angle CXY = 180^\circ$ becomes
 $80^\circ + 60^\circ + \angle CXY = 180^\circ$. Rearranging, we have $\angle CXY = 180^\circ - 80^\circ - 60^\circ = 40^\circ$.

Therefore, $\angle CXY = 40^\circ$.



Problème de la semaine

Problème C

Entre cordes et poteaux

Un parcours d'obstacles est conçu de la manière suivante: deux poteaux sont placés à 12 m l'un de l'autre. Le premier poteau mesure 4 m de haut et le second, 7,5 m. Une première échelle de corde s'étend du sol, à 3 m de la base du premier poteau, jusqu'à son sommet. Une seconde échelle de corde relie les sommets des deux poteaux. Enfin, une troisième échelle de corde relie le sommet du second poteau au sol, à 4 m de sa base. Une illustration du parcours est présentée dans la figure ci-dessous.

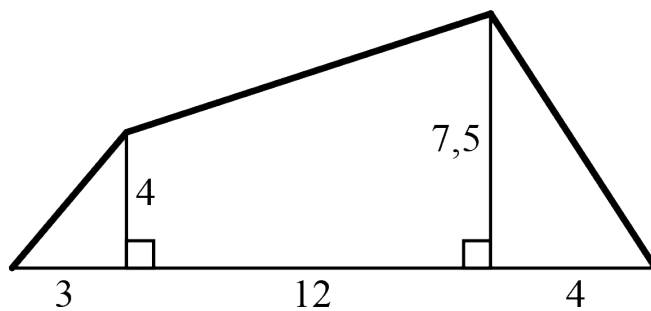

Pour compléter le parcours, Jesse doit grimper le long des trois échelles de corde. Si chaque échelle de corde forme une ligne droite, détermine la distance totale que Jesse doit parcourir sur ces échelles.

REMARQUE: Les renseignements suivants pourraient t'être utiles.

Selon le *théorème de Pythagore*, « dans un triangle rectangle, le carré de la longueur de l'hypoténuse (le côté opposé à l'angle droit) est égal à la somme des carrés des longueurs des deux autres côtés.»

Dans le triangle rectangle ci-dessous, c est l'hypoténuse, a et b sont les longueurs des deux autres côtés et $c^2 = a^2 + b^2$.

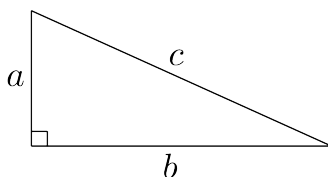



Problem of the Week

Problem C and Solution

Climbing Up and Down

Problem

An obstacle course is created as follows. Two posts, the first being 4 m high and the second being 7.5 m high, are placed 12 m apart. A rope ladder starts on the ground, 3 m from the base of the first post, and finishes at the top of the first post. A second rope ladder connects the tops of the two posts. A third rope ladder starts at the top of the second post and finishes on the ground 4 m from the base of the second post. An illustration of the obstacle course is provided below.

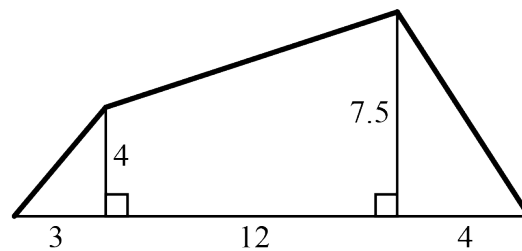

To complete the obstacle course, Jesse has to climb along the three rope ladders. If each of the three rope ladders forms a straight line, then determine the total distance Jesse must travel on the rope ladders.

Solution

We begin by labelling the diagram.

Let P be where the first rope ladder meets the ground.

Let U be the base of the first post and Q be the top of the first post.

Let T be the base of the second post and R be the top of the second post.

Let S be where the third rope ladder meets the ground.

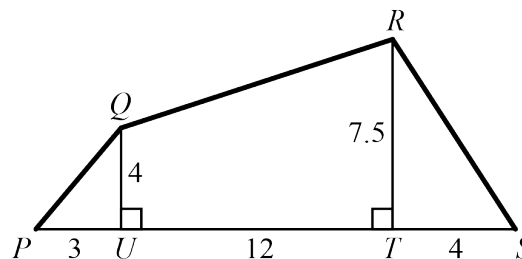

The total distance Jesse must travel on the rope ladders is equal to $PQ + QR + RS$.

First, we will calculate the lengths of PQ and RS .



Since $\angle PUQ = 90^\circ$, we can apply the Pythagorean Theorem in $\triangle PUQ$. Thus, $PQ^2 = QU^2 + PU^2 = 4^2 + 3^2 = 16 + 9 = 25$. Therefore, $PQ = 5$, since $PQ > 0$.

Similarly, $\angle RTS = 90^\circ$, so we can apply the Pythagorean Theorem in $\triangle RTS$. Thus, $RS^2 = RT^2 + TS^2 = 7.5^2 + 4^2 = 56.25 + 16 = 72.25$. Therefore, $RS = 8.5$, since $RS > 0$.

Now we will calculate the length of QR . Draw a line from Q perpendicular to RT . Let A be the point of intersection of the perpendicular with RT . Since QA is perpendicular to RT , $QATU$ is a rectangle. Therefore, $QA = UT = 12$ and $AT = QU = 4$. Thus, $AR = RT - AT = 7.5 - 4 = 3.5$.

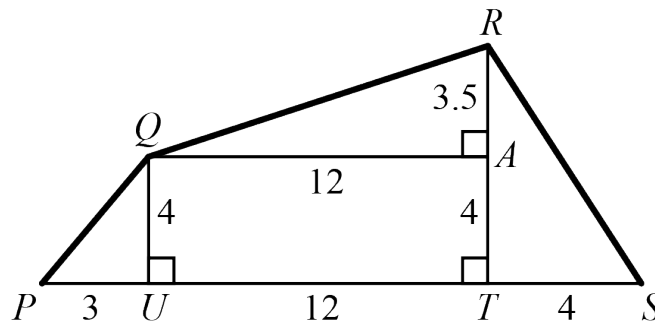

Since $\angle QAR = 90^\circ$, we can apply the Pythagorean Theorem in $\triangle QAR$. Thus, $QR^2 = QA^2 + AR^2 = 12^2 + 3.5^2 = 144 + 12.25 = 156.25$. Therefore, $QR = 12.5$, since $QR > 0$.

Therefore, the total distance Jesse must travel on the rope ladders is $PQ + QR + RS = 5 + 12.5 + 8.5 = 26$ m.



Problème de la semaine

Problème C

Chevauchement 1

Omar dessine le carré $ABCD$ dont les côtés mesurent 4 cm. Jaime dessine ensuite le triangle AED sur le carré $ABCD$ de manière que:

- les côtés AE et DE touchent BC en F et G respectivement,
- FG mesure 3 cm et
- l'aire du triangle AED est le double de l'aire du carré $ABCD$.

Détermine l'aire du triangle FEG .

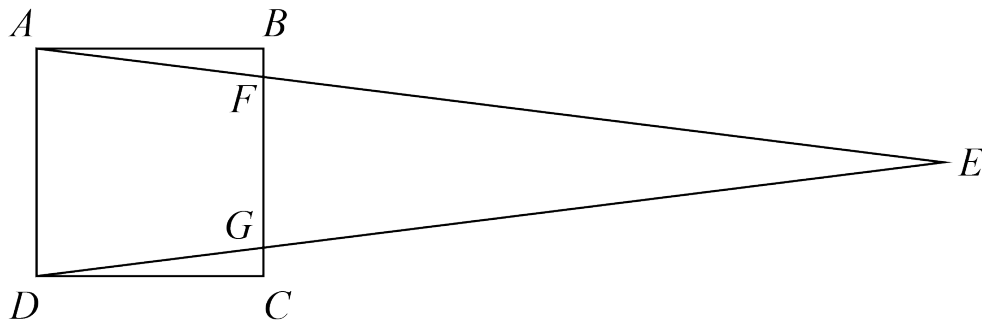

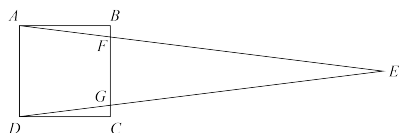

Problem of the Week

Problem C and Solution

Overlapping Shapes 1

Problem

Omar draws square $ABCD$ with side length 4 cm. Jaime then draws $\triangle AED$ on top of square $ABCD$ so that

- sides AE and DE meet BC at F and G , respectively,
- FG is 3 cm, and
- the area of $\triangle AED$ is twice the area of square $ABCD$.

Determine the area of $\triangle FEG$.

Solution

Solution 1

In the first solution we will find the area of square $ABCD$, the area of $\triangle AED$, the area of trapezoid $AFGD$, and then use these to calculate the area of $\triangle FEG$.

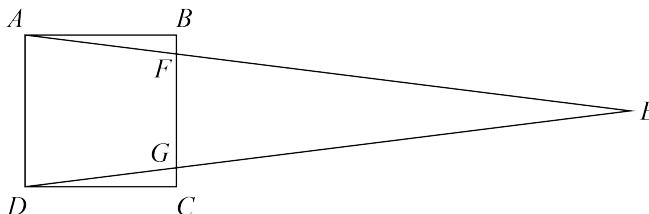

The area of square $ABCD$ is $4 \times 4 = 16 \text{ cm}^2$. Since the area of $\triangle AED$ is twice the area of square $ABCD$, it follows that the area of $\triangle AED$ is $2 \times 16 = 32 \text{ cm}^2$.

Recall that to find the area of a trapezoid, we multiply the sum of the lengths of the two parallel sides by the height, and divide the product by 2. In trapezoid $AFGD$, the two parallel sides are AD and FG , and the height is the width of square $ABCD$, namely AB .

$$\begin{aligned}\text{Area of trapezoid } AFGD &= (AD + FG) \times AB \div 2 \\ &= (4 + 3) \times 4 \div 2 \\ &= 7 \times 4 \div 2 \\ &= 14 \text{ cm}^2\end{aligned}$$

The area of $\triangle FEG$ is equal to the area of $\triangle AED$ minus the area of trapezoid $AFGD$. Thus, the area of $\triangle FEG$ is $32 - 14 = 18 \text{ cm}^2$.



Solution 2

We construct an altitude of $\triangle AED$ from E , intersecting AD at P and BC at Q . Since $ABCD$ is a square, we know that AD is parallel to BC . Therefore, since PE is perpendicular to AD , QE is perpendicular to FG and thus an altitude of $\triangle FEG$. In this solution we will find the height of $\triangle FEG$, that is, the length of QE , and then use this to calculate the area of $\triangle FEG$.

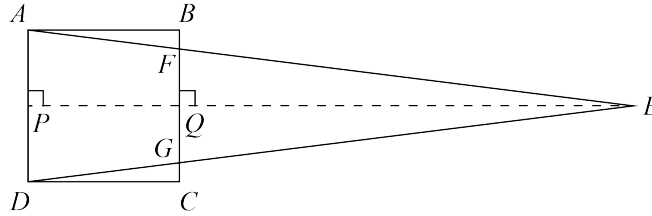

The area of square $ABCD$ is $4 \times 4 = 16 \text{ cm}^2$. Since the area of $\triangle AED$ is twice the area of square $ABCD$, it follows that the area of $\triangle AED$ is $2 \times 16 = 32 \text{ cm}^2$.

We also know that

$$\begin{aligned}\text{Area } \triangle AED &= AD \times PE \div 2 \\ 32 &= 4 \times PE \div 2 \\ 32 &= 2 \times PE \\ PE &= 32 \div 2 \\ &= 16 \text{ cm}\end{aligned}$$

Since $\angle APQ = 90^\circ$, we know that $ABQP$ is a rectangle, and so $PQ = AB = 4$ cm. We also know that $PE = PQ + QE$. Since $PE = 16$ cm and $PQ = 4$ cm, it follows that $QE = PE - PQ = 16 - 4 = 12$ cm. We can then calculate the area of $\triangle FEG$.

$$\begin{aligned}\text{Area } \triangle FEG &= FG \times QE \div 2 \\ &= 3 \times 12 \div 2 \\ &= 18 \text{ cm}^2\end{aligned}$$

Therefore, the area of $\triangle FEG$ is 18 cm^2 .



Problème de la semaine

Problème C

Cubévasion

On crée un grand cube de dimensions $5 \times 5 \times 5$ à partir de petits cubes de dimensions $1 \times 1 \times 1$.

Ensuite, on retire quinze colonnes de ces petits cubes: cinq allant de l'avant vers l'arrière du grand cube, cinq allant du haut vers le bas et cinq allant d'un côté à l'autre. Dans la figure ci-dessous, les colonnes retirées sont représentées par les carrés ombrés.

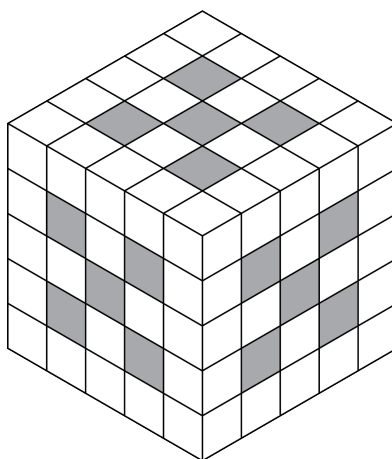

Quel pourcentage du nombre initial de petits cubes $1 \times 1 \times 1$ reste-t-il après que l'on ait retiré ces quinze colonnes?



Problem of the Week

Problem C and Solution

Cubes Be Gone

Problem

A 5 by 5 by 5 cube is formed using identical 1 by 1 by 1 cubes.

Fifteen columns of cubes are then removed, five from front to back, five from top to bottom, and five from side to side. The columns that are removed are indicated by the shaded squares in the following diagram of the cube.

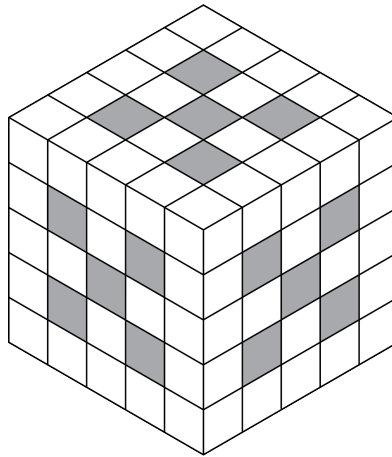

Following the removal of the fifteen columns of cubes, what percentage of the original number of 1 by 1 by 1 cubes remain?

Solution

Solution 1

In this solution, we analyze how many cubes are removed at each of the following stages: when removing the columns from front to back, when removing the columns from top to bottom, and finally when removing the columns from side to side.

When removing columns from the front to the back, 5 smaller cubes are removed from each layer. A total of 25 cubes are removed during this stage.

When removing cubes from top to bottom, since some cubes have already been removed with the front to back columns, the number of cubes removed from each layer is no longer the same. From top to bottom, the number of cubes removed from each layer is 5, 1, 4, 1, and 5. Thus, 16 additional cubes are removed during this stage.

Finally, when removing cubes from side to side, the number of cubes removed at each layer is 5, 1, 4, 1, and 5, the same as the number removed in going from top to bottom. Thus, a total of 16 additional cubes are removed during this final stage.

The total number of cubes removed is $25 + 16 + 16 = 57$. The original 5 by 5 by 5 cube had $5 \times 5 \times 5 = 125$ of the smaller 1 by 1 by 1 cubes. Therefore, there are $125 - 57 = 68$ cubes remaining. The percentage of the original number of 1 by 1 by 1 cubes remaining after the removal of the fifteen columns is $68 \div 125 \times 100\% = 54.4\%$.



Solution 2

The diagram below shows each layer of the 5 by 5 by 5 cube after the columns of cubes have been removed. The cubes that have been removed are shaded in grey.

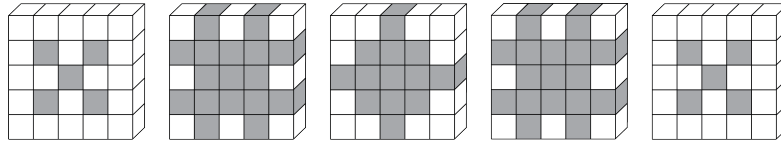

In the first layer, 20 of the 1 by 1 by 1 cubes remain. In the second layer, 8 of the 1 by 1 by 1 cubes remain. In the third layer, 12 of the 1 by 1 by 1 cubes remain. In the fourth layer, 8 of the 1 by 1 by 1 cubes remain. And in the final layer, 20 of the 1 by 1 by 1 cubes remain.

A total of $20 + 8 + 12 + 8 + 20 = 68$ of the 1 by 1 by 1 cubes remain. There were 125 1 by 1 by 1 cubes in the original 5 by 5 by 5 cube.

The percentage of the original number of 1 by 1 by 1 cubes remaining after the removal of the fifteen columns is $68 \div 125 \times 100\% = 54.4\%$.



Problème de la semaine

Problème C

Un cercle divisé

Deux cercles sont dits *concentriques* s'ils ont le même centre.

Dans la figure ci-dessous, on voit deux cercles concentriques. Le petit cercle a un rayon de 5 cm. La région du grand cercle qui est à l'extérieur du petit cercle est divisée en huit parties congrues, chacune ayant la même aire que le petit cercle.

Exprime la circonférence du grand cercle en termes de π .

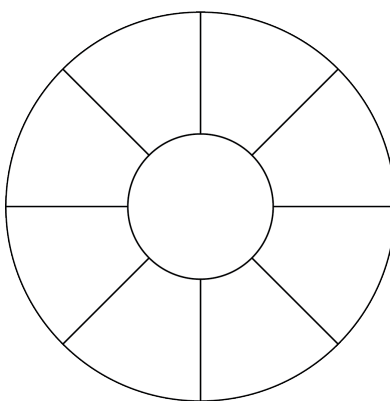



Problem of the Week

Problem C and Solution

A Divided Circle

Problem

Two circles are said to be *concentric* if they have the same centre.

In the diagram below, there are two concentric circles. The radius of the smaller circle is 5 cm. The portion inside the larger circle that is outside of the smaller circle is divided into eight congruent pieces that each have the same area as the smaller circle.

In terms of π , what is the circumference of the larger circle?

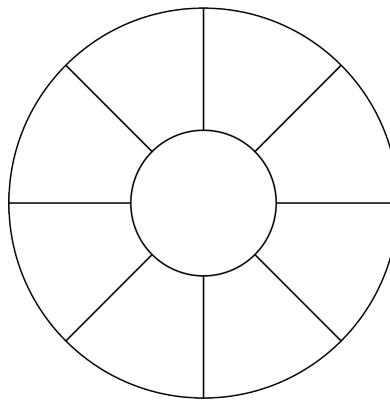

Solution

Since the radius of the smaller circle is 5 cm, it follows that the area of this circle is $\pi(5)^2 = 25\pi \text{ cm}^2$.

To determine the circumference of the larger circle, we will first find its radius.

Let r be the radius of the larger circle. Then the area of the larger circle is $\pi r^2 \text{ cm}^2$.

Since the eight congruent pieces each have the same area as the smaller circle, it follows that this area is equal to $\frac{1}{9}$ of the area of the larger circle. Thus,

$$\begin{aligned}25\pi &= \frac{1}{9}\pi r^2 \\25 &= \frac{1}{9}r^2 \\9 \times 25 &= r^2 \\225 &= r^2\end{aligned}$$

Thus, $r = 15$, since $r > 0$.

It follows that the circumference of the larger circle is $2\pi \times r = 2\pi \times 15 = 30\pi \text{ cm}$.



Problème de la semaine

Problème C

La danse des coordonnées

Les trois points $A(1, 1)$, $B(1, 4)$ et $C(2, 1)$ sont les sommets du triangle ABC .

Voici les transformations que l'on fait subir au triangle :

- Le triangle ABC subit une translation de 4 unités vers la droite.
- Ensuite, l'image subit une réflexion par rapport à l'axe des abscisses.
- Ensuite, l'image de la transformation précédente subit une réflexion par rapport à l'axe des ordonnées.
- Enfin, l'image de la transformation précédente subit une translation de 5 unités vers le haut.

Quelles sont les coordonnées des sommets du triangle après ces transformations ?

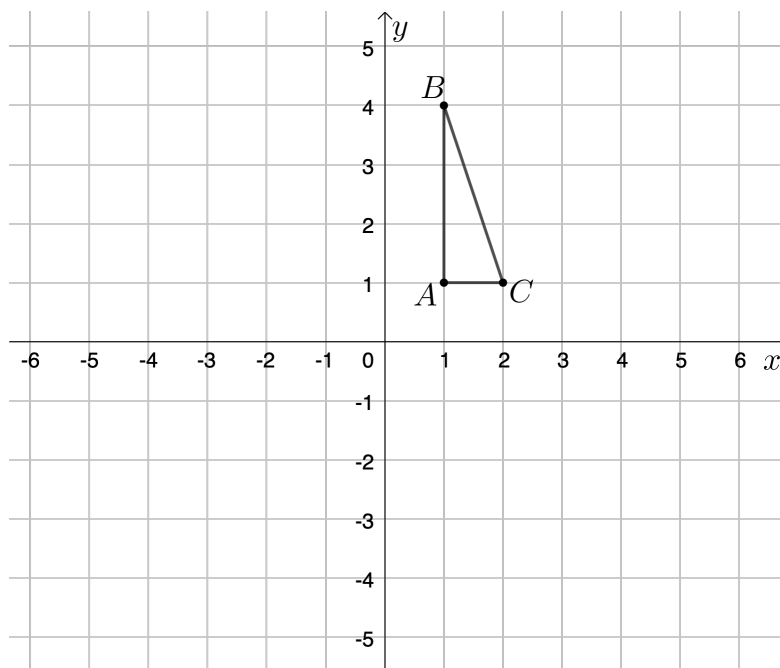

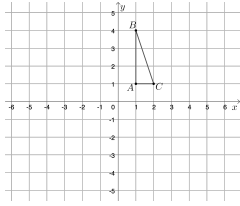

Problem of the Week

Problem C and Solution

Transformational Moves

Problem

The three points $A(1, 1)$, $B(1, 4)$, and $C(2, 1)$ are the vertices of $\triangle ABC$.

We perform transformations to the triangle, as follows. First, we shift $\triangle ABC$ to the right 4 units. Then, we reflect the image in the x -axis. Then, we reflect the new image in the y -axis. Finally, we shift the newest image up 5 units.

What are the coordinates of the vertices of the final triangle?

Solution

In the solution we are going to use notation that is commonly used in transformations. When we transform point A , we label the transformed point as A' . We call this “A prime”. When we transform point A' , we label the transformed point as A'' . We call this “A double prime”. This can continue for all four transformations and for vertices B and C as well.

When $\triangle ABC$ is shifted to the right 4 units, the x -coordinate of each vertex increases by 4. Thus, $\triangle A'B'C'$ has vertices $A'(5, 1)$, $B'(5, 4)$, and $C'(6, 1)$.

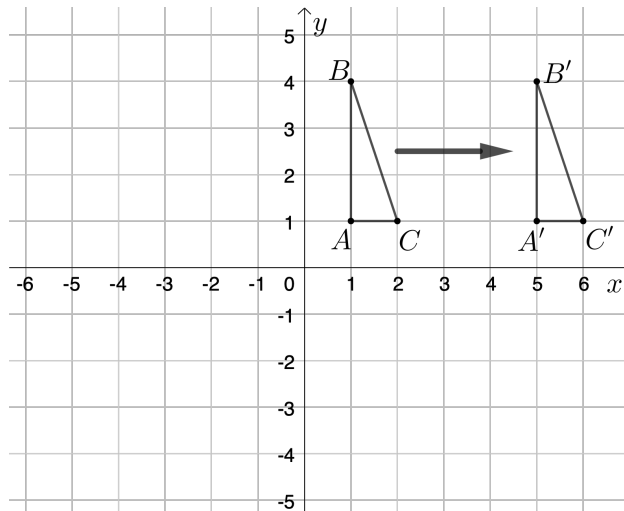

When $\triangle A'B'C'$ is reflected in the x -axis, we multiply the y -coordinate of each vertex by -1 . Thus, $\triangle A''B''C''$ has vertices $A''(5, -1)$, $B''(5, -4)$, and $C''(6, -1)$.

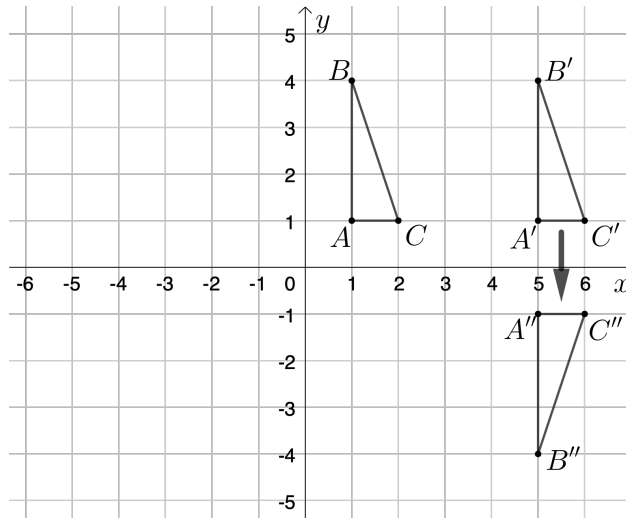

When $\triangle A''B''C''$ is reflected in the y -axis, we multiply the x -coordinate of each vertex by -1 . Thus, $\triangle A'''B'''C'''$ has vertices $A'''(-5, -1)$, $B'''(-5, -4)$, and $C'''(-6, -1)$.

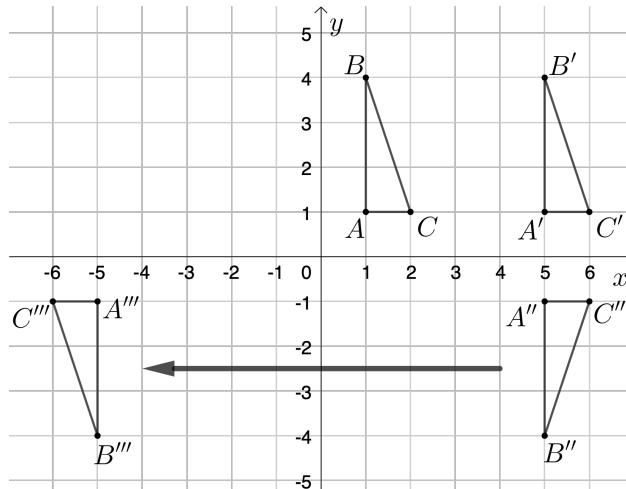

When $\triangle A'''B'''C'''$ is shifted up 5 units, the y -coordinate of each vertex increases by 5. Thus, $\triangle A''''B''''C''''$ has vertices $A''''(-5, 4)$, $B''''(-5, 1)$, and $C''''(-6, 4)$.

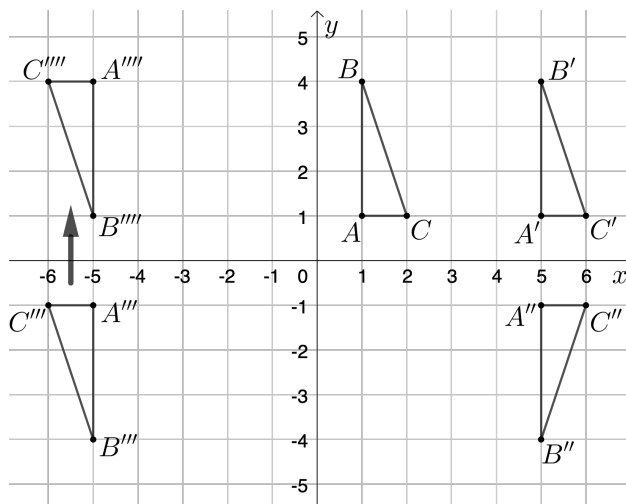

Thus, the final triangle has vertices $A''''(-5, 4)$, $B''''(-5, 1)$ and $C''''(-6, 4)$.



Problème de la semaine

Problème C

Tuile artistique

Sur une tuile de dimensions $8\text{ cm} \times 8\text{ cm}$, on trace une grille composée de lignes parallèles de chaque côté de la tuile à intervalles réguliers de 1 cm . Ensuite, on peint six triangles bleus sur la tuile comme dans la figure ci-dessous.

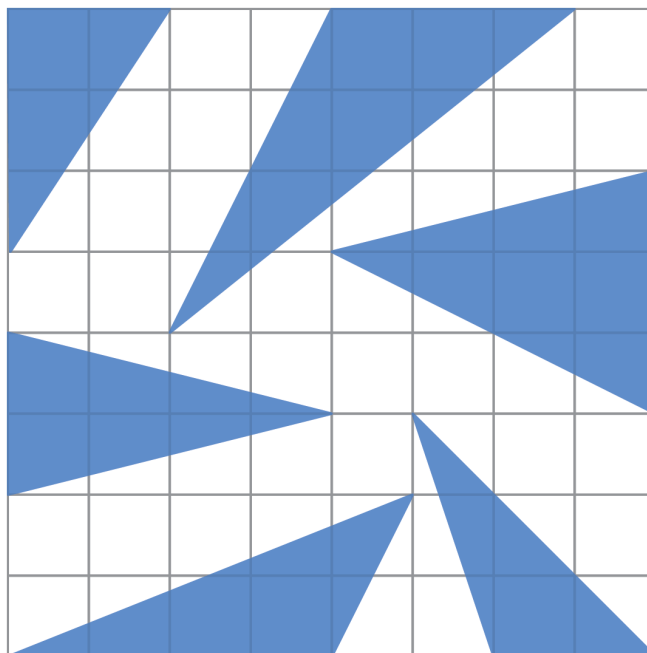

Quelle fraction de la tuile est peinte en bleu ?

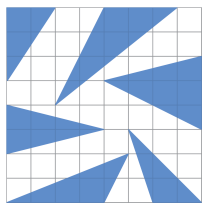

Problem of the Week

Problem C and Solution

Tile Art

Problem

A tile measuring 8 cm by 8 cm has gridlines drawn on it, parallel to each side and spaced 1 cm apart. Six blue triangles are then painted on the tile, as shown. What fraction of the tile is painted blue?

Solution

We will start by determining the areas of the six painted triangles. We label the triangles A , B , C , D , E , and F and draw in a height and a base for each triangle.

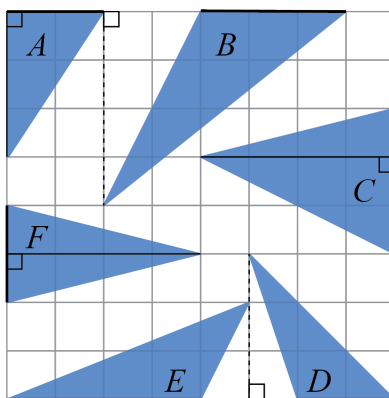

We will calculate the area of each triangle using the formula for the area of a triangle:

$$\text{area} = \frac{\text{base} \times \text{height}}{2}$$

Triangle A has base 2 cm and height 3 cm. The area of triangle A is then $\frac{2 \times 3}{2} = \frac{6}{2} = 3 \text{ cm}^2$.

Triangle B has base 3 cm and height 4 cm. The area of triangle B is then $\frac{3 \times 4}{2} = \frac{12}{2} = 6 \text{ cm}^2$.

Triangle C has base 3 cm and height 4 cm. The area of triangle C is then $\frac{3 \times 4}{2} = \frac{12}{2} = 6 \text{ cm}^2$.

Triangle D has base 2 cm and height 3 cm. The area of triangle D is then $\frac{2 \times 3}{2} = \frac{6}{2} = 3 \text{ cm}^2$.

Triangle E has base 4 cm and height 2 cm. The area of triangle E is then $\frac{4 \times 2}{2} = \frac{8}{2} = 4 \text{ cm}^2$.

Triangle F has base 2 cm and height 4 cm. The area of triangle F is then $\frac{2 \times 4}{2} = \frac{8}{2} = 4 \text{ cm}^2$.

The total area painted blue is then $3 + 6 + 6 + 3 + 4 + 4 = 26 \text{ cm}^2$.

The area of the entire tile is $8 \times 8 = 64 \text{ cm}^2$.

Thus, $\frac{26}{64} = \frac{13}{32}$ of the tile is painted blue.



Sens du nombre (N)

**Amène-moi à la
couverture**



Problème de la semaine

Problème C

Placer des tuiles 1

Ana a neuf tuiles, chacune portant un nombre entier différent de 1 à 9. Ana crée des nombres plus grands en plaçant les tuiles les unes à côté des autres. Par exemple, en utilisant les tuiles 3 et 7, Ana peut créer les nombres à 2 chiffres 37 ou 73.



En utilisant six de ses tuiles, Ana crée deux nombres à 3 chiffres dont la somme est égale à 1000. Quel est le plus grand nombre à 3 chiffres qu'elle aurait pu utiliser ?

$$\begin{array}{r} \square \square \square \\ + \square \square \square \\ \hline 1000 \end{array}$$



Problème de la semaine

Problème C

Partager des raisins

Jessica a des raisins. Elle donne un tiers de ses raisins à Callista. Elle donne ensuite 4 raisins à Monica. Enfin, elle donne la moitié des raisins qui lui restent à Peter. Ensuite, s'il reste 16 raisins à Jessica, combien de raisins Jessica avait-t-elle au début ?

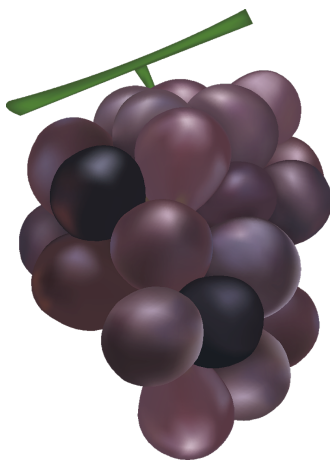

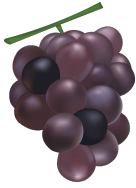

Problem of the Week

Problem C and Solution

Sharing Grapes

Problem

Jessica has some grapes. She gives one-third of her grapes to Callista. She then gives 4 grapes to Monica. Finally, she gives one-half of her remaining grapes to Peter. If Jessica then has 16 grapes left, how many grapes did Jessica begin with?

Solution

Solution 1:

We work backwards from the last piece of information given.

Jessica has 16 grapes left after giving one-half of her remaining grapes to Peter. This means that she had $2 \times 16 = 32$ grapes immediately before giving grapes to Peter.

Immediately before giving grapes to Peter, she gave 4 grapes to Monica, which means that she had $32 + 4 = 36$ grapes immediately before giving 4 grapes to Monica.

Immediately before giving the 4 grapes to Monica, she gave one-third of her grapes to Callista, which would have left her with two-thirds of her original amount.

Since two-thirds of her original amount equals 36 grapes, then one-third equals one half of 36 or $\frac{36}{2} = 18$ grapes.

Thus, she gave 18 grapes to Callista, and so Jessica began with $36 + 18 = 54$ grapes.

Solution 2:

Suppose Jessica started with x grapes.

She gives $\frac{1}{3}x$ grapes to Callista, leaving her with $1 - \frac{1}{3}x = \frac{2}{3}x$ grapes.

She then gives 4 grapes to Monica, leaving her with $\frac{2}{3}x - 4$ grapes.

Finally, she gives away one-half of what she has left to Peter, which means that she keeps one-half of what she has left, and so she keeps $\frac{1}{2}(\frac{2}{3}x - 4)$ grapes.

Simplifying this expression, we obtain $\frac{2}{6}x - \frac{4}{2} = \frac{1}{3}x - 2$ grapes.

Since she has 16 grapes left, then $\frac{1}{3}x - 2 = 16$ and so $\frac{1}{3}x = 18$ or $x = 54$.

Therefore, Jessica began with 54 grapes.



Problème de la semaine

Problème C

Observation céleste

Dans un système solaire éloigné, quatre comètes distinctes: la comète Hypatie, la comète Fibonacci, la comète Lovelace et la comète Euclide, ont simultanément traversé le ciel de la planète Ptolémée en 2023. Sur Ptolémée, on sait que la comète Hypatie se manifeste tous les 3 ans, la comète Fibonacci tous les 6 ans, la comète Lovelace tous les 8 ans et la comète Euclide tous les 15 ans.

En quelle année les quatre comètes traverseront-elles simultanément le ciel de Ptolémée ?

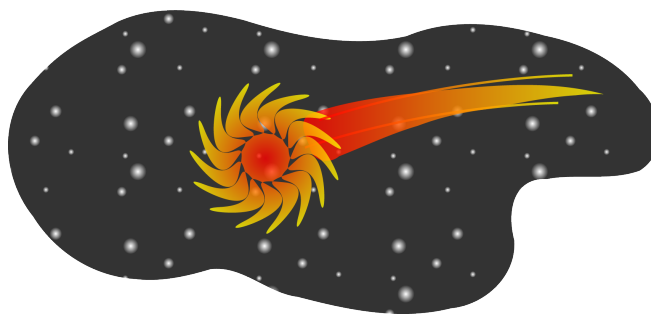



Problem of the Week

Problem C and Solution

Stargazing

Problem

In a distant solar system, four different comets: Hypatia, Fibonacci, Lovelace, and Euclid, passed by the planet Ptolemy in 2023. On Ptolemy, it is known that the Hypatia comet appears every 3 years, the Fibonacci comet appears every 6 years, the Lovelace comet appears every 8 years, and the Euclid comet appears every 15 years.

When is the next year that all four comets will pass by Ptolemy?

Solution

Since the Hypatia comet appears every 3 years, it will pass by Ptolemy in the following numbers of years: 3, 6, 9, 12, 15, 18, 21, 24, 27, 30....

Since the Fibonacci comet appears every 6 years, it will pass by Ptolemy in the following numbers of years: 6, 12, 18, 24, 30,....

Therefore, both the Hypatia and Fibonacci comets will pass by Ptolemy in the following numbers of years: 6, 12, 18, 24, 30,....

This happens because these numbers are *common multiples* of 3 and 6. If we want to determine when all four comets next pass by Ptolemy, we need to find the *least common multiple* (LCM) of 3, 6, 8, and 15. We shall do this in two ways.

Solution 1

The first way to find the LCM is to list the positive multiples of 3, 6, 8, and 15, until we find a common multiple in each list.

Number	Positive Multiples
3	3, 6, 9, 12, 15, 18, 21, ..., 108, 111, 114, 117, 120 , 123, ...
6	6, 12, 18, 24, 30, 36, 42, ..., 96, 102, 108, 114, 120 , 126, ...
8	8, 16, 24, 32, 40, 48, 56, ..., 104, 112, 120 , 128, ...
15	15, 30, 45, 60, 75, 90, 105, 120 , 135, ...

Thus, the LCM of 3, 6, 8, and 15 is 120. Therefore, the next time all four planets will pass by Ptolemy is in 120 years. This will be the year 2143.



Solution 2

The second way to determine the LCM is to rewrite 3, 6, 8, and 15 as a prime or a product of prime numbers. (This is known as *prime factorization*.)

- $3 = 3$
- $6 = 2 \times 3$
- $8 = 2 \times 2 \times 2$
- $15 = 3 \times 5$

The LCM is calculated by determining the greatest number of each prime number in any of the factorizations (here we will have three 2s, one 3, and one 5), and then multiplying these numbers together. This gives $2 \times 2 \times 2 \times 3 \times 5 = 120$. Therefore, the next time all four planets will pass by Ptolemy is in 120 years. This will be the year 2143.

NOTE: The second method is a more efficient way to find the LCM, especially when the numbers are quite large.



Problème de la semaine

Problème C

Étalage de fruits

Jigme a disposé cinq oranges en rangée sur un long plateau. Ensuite, il a placé une pomme dans chaque espace entre deux oranges.

Puis, il a placé une banane dans chaque espace entre deux fruits de la rangée.

Il a ensuite répété cette procédure avec des poires, puis des pêches et enfin avec des fraises.

Détermine le nombre total de fruits dans la rangée.

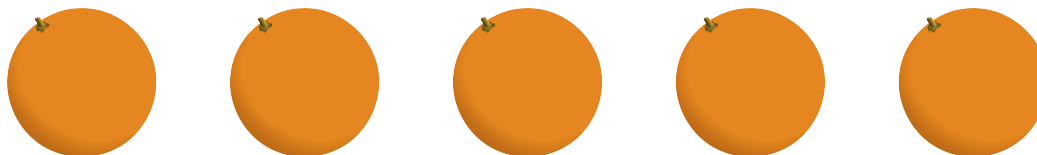



Problem of the Week



Problem C and Solution

Fruit Display

Problem

Jigme placed five oranges in a row on a long plate. He then placed one apple in each of the spaces in the row between two oranges.

Next, he placed one banana in each of the spaces between two fruits already in the row.

He then repeated this procedure with pears, then peaches, and finally with strawberries.

Determine the total number of fruits in the row.

Solution

After placing 5 oranges in the row, there are 4 spaces between the fruits. So Jigme placed 4 apples in the row. At this point, there are $5 + 4 = 9$ fruits in the row.

Since there are now 9 fruits in the row, there are 8 spaces between the fruits. So Jigme placed 8 bananas in the row. At this point, there are $9 + 8 = 17$ fruits in the row.

Since there are now 17 fruits in the row, there are 16 spaces between the fruits. So Jigme placed 16 pears in the row. At this point, there are $17 + 16 = 33$ fruits in the row.

Since there are now 33 fruits in the row, there are 32 spaces between the fruits. So Jigme placed 32 peaches in the row. At this point, there are $33 + 32 = 65$ fruits in the row.

Finally, since there are now 65 fruits in the row, there are 64 spaces between the fruits. So Jigme placed 64 strawberries in the row. At this point, there are $65 + 64 = 129$ fruits in the row.

Thus, there are 129 fruits in the row in total.

EXTENSION:

You may have noticed a pattern in the total number of fruits after each new fruit was added. If Jigme placed fruits in this way using n different fruits, there will be a total of $2^{n+1} + 1$ fruits in the row. Can you see why? Start by looking at the number of spaces between the fruits.



Problème de la semaine

Problème C

Récolte fruitée

Owen, Gabriel et Ariane travaillent comme cueilleurs de fraises dans une ferme locale. Une semaine, Owen a cueilli 135 fraises de plus que Gabriel et Ariane a cueilli 110 fraises de plus qu'Owen. En tout cette semaine, Owen, Gabriel et Ariane ont cueilli 2000 fraises.

Détermine le nombre de fraises que chaque personne a cueilli.





Problem of the Week

Problem C and Solution

Berry Picking

Problem

Owen, Gabriel, and Ariane work as strawberry pickers at a local farm. One week Owen picked 135 more strawberries than Gabriel, and Ariane picked 110 more strawberries than Owen. In total that week Owen, Gabriel, and Ariane picked 2000 strawberries.

Determine the number of strawberries that each person picked.

Solution

Solution 1

Let g be the number of strawberries that Gabriel picked. It follows that Owen picked $(g + 135)$ strawberries and Ariane picked $(g + 135 + 110)$ strawberries. Since they picked 2000 strawberries in total, we can write and solve the following equation:

$$g + (g + 135) + (g + 135 + 110) = 2000$$

$$g + (g + 135) + (g + 245) = 2000$$

$$3g + 380 = 2000$$

$$3g = 1620$$

$$g = 540$$

So, $g + 135 = 675$ and $g + 135 + 110 = 785$.

Thus, Gabriel picked 540 strawberries, Owen picked 675 strawberries, and Ariane picked 785 strawberries.

Solution 2

If Owen had picked 135 fewer strawberries, and Ariane had picked $135 + 110 = 245$ fewer strawberries, then each would have picked the same number of strawberries as Gabriel. In that case, each person would have picked $\frac{1}{3}$ of $(2000 - 135 - 245)$, which is $\frac{1}{3} \times 1620 = 540$ strawberries.

Thus, Gabriel picked 540 strawberries. Then Owen picked $540 + 135 = 675$ strawberries and Ariane picked $540 + 245 = 785$ strawberries.



Problème de la semaine

Problème C

Les nombres entiers sont...

John et Betty choisissent chacun un nombre entier strictement positif supérieur à 1. Betty ajoute 1 à son entier. John prend ensuite ce nouveau nombre et le multiplie par son entier pour obtenir 260 comme produit.

Sachant que le nombre entier de Betty est plus grand que celui de John, détermine toutes les paires possibles de nombres entiers que John et Betty auraient pu choisir.

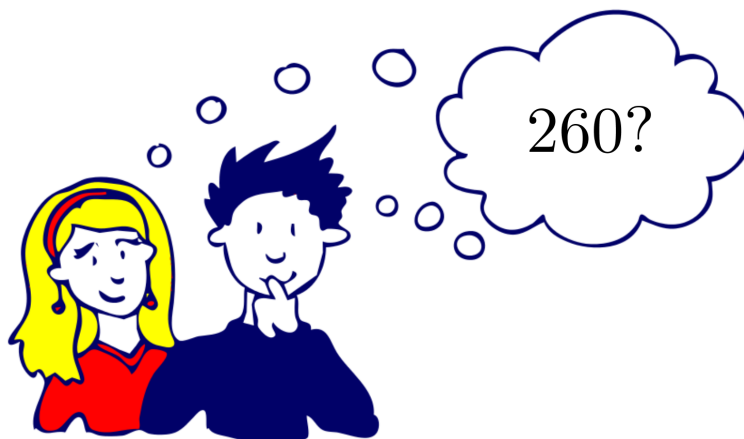



Problem of the Week

Problem C and Solution

And the Numbers Are...

Problem

John and Betty each choose a positive integer that is greater than 1. Betty increases her number by 1. John then takes this new number and multiplies it by his number. This product is equal to 260.

If Betty's number is larger than John's number, determine all possible pairs of integers that John and Betty could have chosen.

Solution

Let John's integer be j and Betty's integer be b . We're given $j \times (b + 1) = 260$.

In considering the equation $j \times (b + 1) = 260$, we are looking for two integers, each greater than 1, that multiply to 260. We also want Betty's integer b to be greater than John's integer j .

We generate the following list of ways to factor 260 as a product of two integers:

$$1 \times 260, 2 \times 130, 4 \times 65, 5 \times 52, 10 \times 26, 13 \times 20$$

We can exclude $260 = 1 \times 260$ because both integers must be greater than 1.

Since Betty's integer is larger than John's integer, we get the following possibilities:

- $j = 2$ and $b + 1 = 130$. Thus, $j = 2$ and $b = 129$.
- $j = 4$ and $b + 1 = 65$. Thus, $j = 4$ and $b = 64$.
- $j = 5$ and $b + 1 = 52$. Thus, $j = 5$ and $b = 51$.
- $j = 10$ and $b + 1 = 26$. Thus, $j = 10$ and $b = 25$.
- $j = 13$ and $b + 1 = 20$. Thus, $j = 13$ and $b = 19$.

Therefore, there are five pairs of integers that John and Betty could have chosen. John could have chosen 2 and Betty chose 129, John could have chosen 4 and Betty chose 64, John could have chosen 5 and Betty chose 51, John could have chosen 10 and Betty chose 25, or John could have chosen 13 and Betty chose 19.



Problème de la semaine

Problème C

Jetons en jeu

Monsieur Chips a un bac rempli de jetons de bingo. Le rapport du nombre de jetons rouges au nombre de jetons bleus est de $1 : 4$ et le rapport du nombre de jetons bleus au nombre de jetons verts est de $5 : 2$.

Quel est le rapport du nombre de jetons rouges au nombre de jetons verts ?

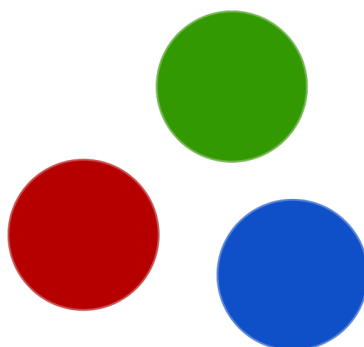



Problem of the Week

Problem C and Solution

Chip to Chip

Problem

Mr. Chips has a bin full of bingo chips. The ratio of the number of red chips to the number of blue chips is $1 : 4$, and the ratio of the number of blue chips to the number of green chips is $5 : 2$.

What is the ratio of the number of red chips to the number of green chips?

Solution

Solution 1

We start by assuming that there are 20 blue chips. (We pick 20 since the ratio of red chips to blue chips is $1 : 4$ and the ratio of blue chips to green chips is $5 : 2$, so we pick a number of blue chips which is divisible by 4 and by 5. Note that we did not have to assume that there were 20 blue chips, but making this assumption makes the calculations much easier.)

Since there are 20 blue chips and the ratio of the number of red chips to the number of blue chips is $1 : 4$, then there are $\frac{1}{4} \times 20 = 5$ red chips.

Since there are 20 blue chips and the ratio of the number of blue chips to the number of green chips is $5 : 2$, then there are $\frac{5}{2} \times 20 = 8$ green chips.

Therefore, the ratio of the number of red chips to the number of green chips is $5 : 8$.

Solution 2

Let r represent the number of red chips.

Since the ratio of the number of red chips to the number of blue chips is $1 : 4$, then the number of blue chips is $4r$.

Since the ratio of the number of blue chips to the number of green chips is $5 : 2$, then the number of green chips is $\frac{2}{5} \times 4r = \frac{8}{5}r$.

Since the number of red chips is r and the number of green chips is $\frac{8}{5}r$, then the ratio of the number of red chips to the number of green chips is $1 : \frac{8}{5} = 5 : 8$.



Problème de la semaine

Problème C

Pièces en folie

Jean a donné à Karyna un sac de pièces de monnaie contenant uniquement des pièces de 5 cents et de 10 cents. La valeur totale des pièces dans le sac était de 11 \$ et il y avait 16 pièces de 5 cents de plus que de pièces de 10 cents dans le sac.

Combien y avait-il de pièces au total dans le sac ?



NOTE : Au Canada, 100 cents équivalent 1 \$.



Problem of the Week

Problem C and Solution

Gimme Some Change

Problem

Jean gave Karyna a bag of coins containing only nickels (5 cent coins) and dimes (10 cent coins). The total value of all the coins in the bag was \$11 and there were 16 more nickels than dimes in the bag.

How many coins in total were in the bag?

NOTE: In Canada, 100 cents is equal to \$1.

Solution

Solution 1

In this solution, we will solve the problem without using algebra.

The bag had 16 more nickels than dimes. These 16 nickels are worth $16 \times 5 = 80$ cents, or \$0.80. The remaining $\$11.00 - \$0.80 = \$10.20$ would be made up using an equal number of nickels and dimes. Each nickel-dime pair is worth 15 cents, or \$0.15. By dividing \$10.20 by \$0.15 we determine the number of nickel-dime pairs that are required to make \$10.20. Since $\$10.20 \div \$0.15 = 68$, we need 68 nickel-dime pairs. That is, we need 68 nickels and 68 dimes to make \$10.20. But there were 16 more nickels in the bag. Therefore, there were a total of $68 + 68 + 16 = 152$ coins in the bag.

Solution 2

In this solution, we will solve the problem using algebra.

Let d represent the number of dimes. Since there were 16 more nickels than dimes in the bag, then there were $(d + 16)$ nickels in the bag. Since each dime is worth 10 cents, the value of d dimes is $10d$ cents.

Since each nickel is worth 5 cents, the value of $(d + 16)$ nickels is $5(d + 16)$ cents. The bag contains a total value of \$11 or 1100 cents. Therefore,

$$\text{Value of Dimes (in cents)} + \text{Value of Nickels (in cents)} = \text{Total Value (in cents)}$$

$$10d + 5(d + 16) = 1100$$

$$10d + 5d + 80 = 1100$$

$$15d = 1100 - 80$$

$$15d = 1020$$

$$d = 68$$

$$d + 16 = 84$$

Therefore, there were 68 dimes and 84 nickels for a total of $68 + 84 = 152$ coins in the bag.



Problème de la semaine

Problème C

Où va l'année ?

On dispose en rangées les entiers strictement positifs en ordre consécutif, chaque rangée comprenant sept nombres entiers. C'est-à-dire que la première rangée contient les entiers 1, 2, 3, 4, 5, 6 et 7. La deuxième rangée contient les entiers 8, 9, 10, 11, 12, 13 et 14. La troisième rangée contient les entiers 15, 16, 17, 18, 19, 20 et 21 et ainsi de suite.

Détermine la rangée et la colonne dans lesquelles se trouve le nombre entier 2024.

1 2 3 4 5 6 7

8 9 10 11 12 13 14

15 16 17 18 19 20 21

⋮ ⋮ ⋮ ⋮ ⋮ ⋮ ⋮



Problem of the Week

Problem C and Solution

Where Does the Year Go?

Problem

The positive integers are written consecutively in rows, with seven integers in each row. That is, the first row contains the integers 1, 2, 3, 4, 5, 6, and 7. The second row contains the integers 8, 9, 10, 11, 12, 13, and 14. The third row contains the integers 15, 16, 17, 18, 19, 20, and 21, and so on.

Determine the row and the column that the integer 2024 is in.

1	2	3	4	5	6	7
8	9	10	11	12	13	14
15	16	17	18	19	20	21
⋮	⋮	⋮	⋮	⋮	⋮	⋮

Solution

The last number in row 1 is 7, the last number in row 2 is 14, and the last number in row 3 is 21. Observe that the last number in each row is a multiple of 7. Furthermore, the last number in row n is $7 \times n$. So, we will find the largest multiple of 7 that is less than 2024.

We solve the equation $7 \times n = 2024$ to get $n \approx 289.14$.

Therefore, the largest multiple of 7 that is less than 2024 is $289 \times 7 = 2023$. This means that 2023 is the last number in row 289. Thus, 2024 will be the first number in in row 290.

Therefore, 2024 is in row 290 and column 1.



Problème de la semaine

Problème C

Masse problématique

Ron a dix sphères identiques et dix cubes identiques. On lui a demandé de calculer la masse totale des dix sphères et des dix cubes, mais il n'a pas de balance fiable à sa disposition. Cependant, il sait que :

- Deux sphères et trois cubes ont une masse de 21 g.
- Trois sphères et deux cubes ont une masse de 19 g.

Ta tâche est de déterminer la masse totale des dix sphères et des dix cubes.

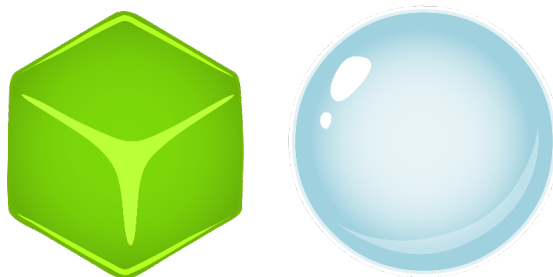



Problem of the Week

Problem C and Solution

A Weighty Problem

Problem

Ron has ten identical spheres and ten identical cubes. He was asked to determine the combined mass of the ten spheres and ten cubes, but he did not have a reliable weigh scale. However, he was given the following information:

- Two spheres and three cubes have a mass of 21 g.
- Three spheres and two cubes have a mass of 19 g.

Your task is to determine the combined mass of the ten spheres and ten cubes.

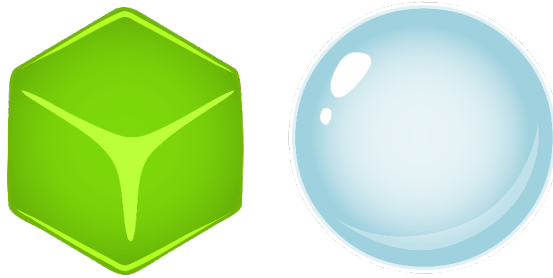

Solution

Solution 1

Since two spheres and three cubes have a mass of 21 g and three spheres and two cubes have a mass of 19 g, then, by combining the two pieces of information, we know that five spheres and five cubes have a combined mass of $21 + 19 = 40$ g. If we double this, we find that ten spheres and ten cubes have a combined mass of $40 \times 2 = 80$ g.

Solution 2

From the first piece of given information to the second, the number of spheres has been increased by one and the number of cubes has been decreased by one. This causes a mass decrease of 2 g. Therefore, the mass of the cube is 2 g more than the mass of the sphere.

Let s represent the mass, in grams, of one sphere.

Therefore, the mass, in grams, of one cube is $s + 2$.

From the first piece of information, we know $2s + 3(s + 2) = 21$. We now solve this equation.



$$2s + 3(s + 2) = 21$$

$$2s + 3s + 6 = 21$$

$$5s + 6 = 21$$

$$5s = 15$$

$$s = 3$$

Therefore, one sphere has a mass of 3 g and one cube has a mass $3 + 2 = 5$ g.

Thus, the combined mass of ten spheres and ten cubes is $10 \times 3 + 10 \times 5 = 30 + 50 = 80$ g.

Solution 3

This solution uses algebra that is learned in future mathematics courses.

Let s represent the mass, in grams, of a sphere.

Let c represent the mass, in grams, of a cube.

Using the given information, we obtain the following system of equations.

$$2s + 3c = 21 \tag{1}$$

$$3s + 2c = 19 \tag{2}$$

We will now use elimination to solve for s and c .

First, multiplying equation (1) by 2, we get

$$4s + 6c = 42 \tag{3}$$

Multiplying equation (2) by 3, we get

$$9s + 6c = 57 \tag{4}$$

Subtracting equation (3) from equation (4), we get $5s = 15$, and so $s = 3$.

Substituting $s = 3$ into equation (1), we have

$$2(3) + 3c = 21$$

$$6 + 3c = 21$$

$$3c = 15$$

$$c = 5$$

Therefore, one sphere has a mass of 3 g and one cube has a mass 5 g.

Thus, the combined mass of ten spheres and ten cubes is $10 \times 3 + 10 \times 5 = 30 + 50 = 80$ g.



Problème de la semaine

Problème C

Un multiple problématique

Combien y a-t-il de nombres entiers entre 100 et 2024 qui sont des multiples à la fois de 5 et de 7, mais qui ne sont pas des multiples de 10 ?

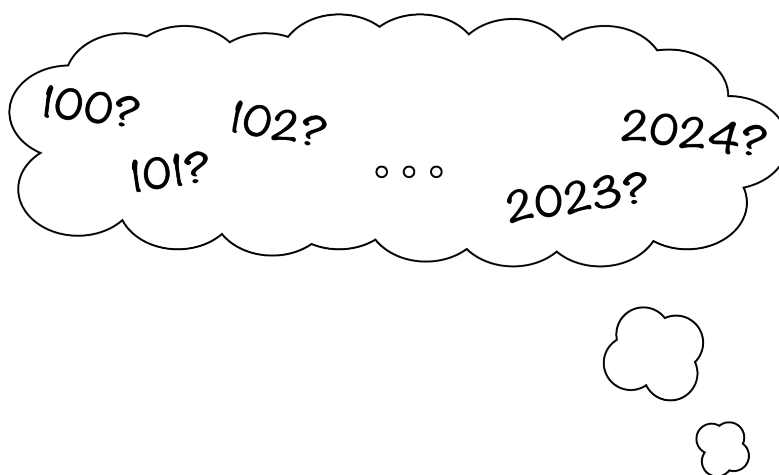

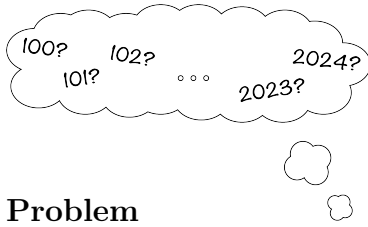

Problem of the Week

Problem C and Solution

A Multiple Problem

Problem

How many integers between 100 and 2024 are multiples of both 5 and 7, but are not multiples of 10?

Solution

The integers that are multiples of both 5 and 7 are the integers that are multiples of 35. Now let's determine which multiples of 35 are also multiples of 10. Notice that $1 \times 35 = 35$, which is not a multiple of 10. However, $2 \times 35 = 70$, which is a multiple of 10. In fact, multiplying 35 by any even integer will result in a multiple of 10. This is because 35 is a multiple of 5, and all even integers are multiples of 2. So multiplying 35 by an even integer will result in an integer which is a multiple of both 5 and 2, and thus a multiple of 10. So if we are looking for integers that are multiples of 35 but not multiples of 10, then we must multiply 35 by odd integers only.

The smallest multiple of 35 greater than 100 is $3 \times 35 = 105$. Similarly, the largest multiple of 35 less than 2024 is $57 \times 35 = 1995$. It follows that the number of integers between 100 and 2024 that are multiples of both 5 and 7, but are not multiples of 10, is equal to the number of odd integers between 3 and 57, inclusive. This is equal to the number of odd integers between 1 and 55, inclusive. We know that exactly half of the integers between 1 and 54 are odd, and 55 is an odd integer. So in total, there are $\frac{54}{2} + 1 = 27 + 1 = 28$ odd integers between 1 and 55, inclusive.

Thus, there are 28 integers between 100 and 2024 that are multiples of both 5 and 7, but are not multiples of 10.



Problème de la semaine

Problème C

Un test éclair moyen

On a les informations suivantes concernant un test éclair récent portant sur les moyennes:

- Le test comportait trois questions.
- Chaque question valait 5 points.
- Chaque question a été notée juste ou fausse (pas de note partielle).
- 30 % des élèves ont répondu correctement aux 3 questions.
- 40 % des élèves ont répondu correctement à exactement 2 questions.
- 25 % des élèves ont répondu correctement à exactement 1 question.
- 5 % des élèves n'ont eu aucune bonne réponse.

Détermine la moyenne générale de la classe pour ce test.





Problem of the Week

Problem C and Solution

An Average Quiz

Problem

For a recent quiz about averages, the following information is known:

- There were three questions on the quiz.
- Each question was worth 5 marks.
- Each question was marked right or wrong (no part marks).
- 30% of the students got all 3 questions correct.
- 40% of the students got exactly 2 questions correct.
- 25% of the students got exactly 1 question correct.
- 5% of the students got no question correct.

Determine the overall class average for this quiz.

Solution

Solution 1

To determine the average, we must determine the sum of all the marks and divide by the number of students. We will use the information given for a class of 100 students.

Since 30% of the students got all 3 questions correct, 30 students each scored 15 marks and earned a total of $30 \times 15 = 450$ marks.

Since 40% of the students got exactly 2 questions correct, 40 students each scored 10 marks and earned a total of $40 \times 10 = 400$ marks.

Since 25% of the students got exactly 1 question correct, 25 students each scored 5 marks and earned a total of $25 \times 5 = 125$ marks.

Since 5% of the students got no questions correct, 5 students scored 0 marks and earned a total of $5 \times 0 = 0$ marks.

The total number of marks earned by the 100 students was $450 + 400 + 125 + 0 = 975$.

The average mark on the quiz was then $975 \div 100 = 9.75$ out of 15, or 65%.



Solution 2

To determine an average, we must determine the total of all the marks and divide by the number of students.

Let n represent the number of students who wrote the test where n is a positive integer.

Since 30% of the students got all 3 questions correct, $0.30n$ students each scored 15 marks and earned a total of $0.30n \times 15 = 4.5n$ marks.

Since 40% of the students got exactly 2 questions correct, $0.40n$ students each scored 10 marks and earned a total of $0.40n \times 10 = 4n$ marks.

Since 25% of the students got exactly 1 question correct, $0.25n$ students each scored 5 marks and earned a total of $0.25n \times 5 = 1.25n$ marks.

Since 5% of the students got no questions correct, $0.05n$ students scored 0 marks and earned a total of $0.05n \times 0 = 0$ marks.

The total number of marks earned by the n students was

$$4.5n + 4n + 1.25n + 0 = 9.75n.$$

The average mark on the quiz was then $\frac{9.75n}{n} = 9.75$ (since $n \neq 0$) out of 15, or 65%.



Problème de la semaine

Problème C

Année bissextile 1

La plupart des gens croient qu'une année compte 365 jours, mais en réalité, elle en compte légèrement plus. Pour ajuster ce surplus de temps, on a recours aux années bissextiles. Ces dernières sont des années qui contiennent un jour de plus.

On peut utiliser l'organigramme ci-contre pour déterminer si une année donnée est bissextile ou non. D'après l'organigramme :

- l'année 2018 n'était **pas** une année bissextile car 2018 n'est pas divisible par 4.
- l'année 2016 était une année bissextile car 2016 est divisible par 4, mais n'est pas divisible par 100.
- l'année 2100 ne sera **pas** une année bissextile car 2100 est divisible par 4 et par 100, mais n'est pas divisible par 400.
- l'année 2000 était une année bissextile car 2000 est divisible par 4, par 100 et par 400.

Combien y a-t-il d'années bissextiles entre les années 2000 et 2400 inclusivement ?

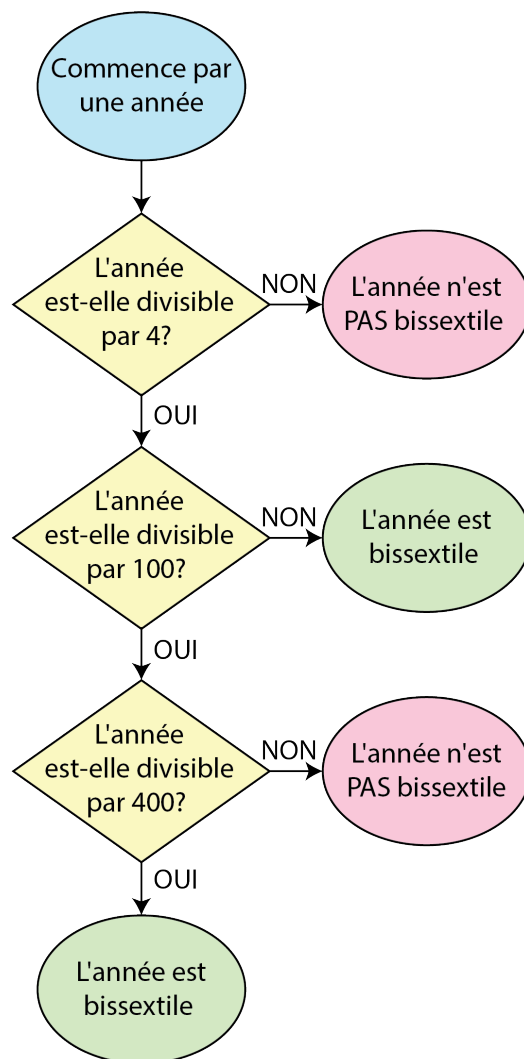



Problem of the Week

Problem C and Solution

A Small Leap

Problem

Most people think of a year as 365 days, however it is actually slightly more than 365 days. To account for this extra time we use leap years, which are years containing one extra day.

The flowchart shown can be used to determine whether or not a given year is a leap year. Using the flowchart, we can conclude the following:

- 2018 was **not** a leap year because 2018 is not divisible by 4.
- 2016 was a leap year because 2016 is divisible by 4, but not 100.
- 2100 will **not** be a leap year because 2100 is divisible by 4 and 100, but not 400.
- 2000 was a leap year because 2000 is divisible by 4, 100, and 400.

How many leap years are there between the years 2000 and 2400, inclusive?

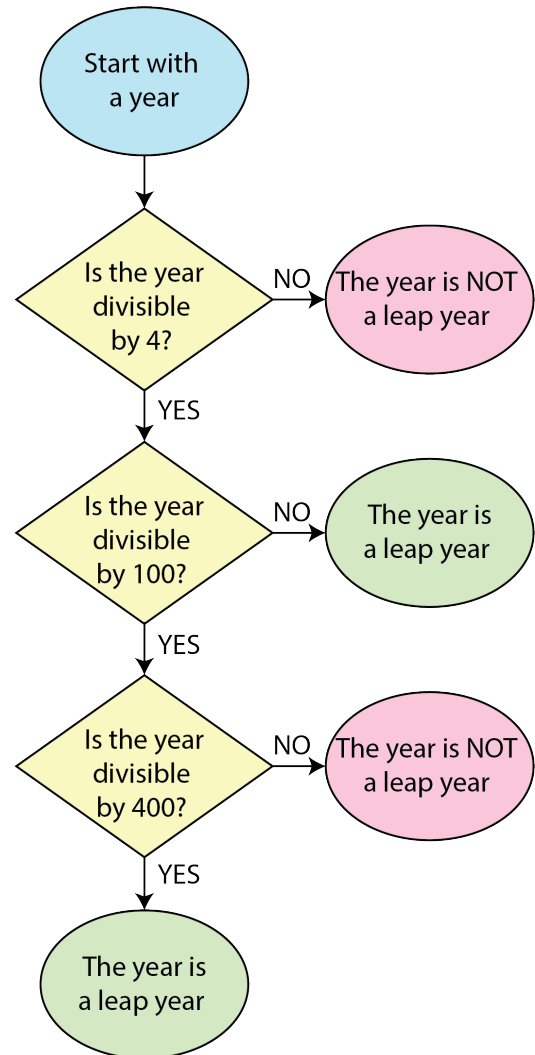



Solution

From the flowchart we can determine that leap years are either

- multiples of 4 that are not also multiples of 100, or
- multiples of 4, 100, and 400.

Note that we can simplify the second case to just multiples of 400, since any multiple of 400 will also be a multiple of 4 and 100.

First we notice that 2000 and 2400 are both multiples of 400, so they are both leap years. In fact, they are the only multiples of 400 between 2000 and 2400, inclusive.

Next we count the multiples of 4 between 2000 and 2400, inclusive. Writing out some of the first few multiples of 4 gives: 2000, 2004, 2008, 2012, . . .

We will look at the 400 numbers from 2000 to 2399 and ignore 2400 for the moment since we already know it's a leap year. Since 2000 is a multiple of 4 and every fourth number after that is also a multiple of 4, it follows that $\frac{1}{4}$ of the 400 numbers from 2000 to 2399 will be multiples of 4. Thus, there are $\frac{1}{4} \times 400 = 100$ multiples of 4 between 2000 and 2399, inclusive.

However, we have included the multiples of 100, so we need to subtract these. These are 2000, 2100, 2200, and 2300. Thus there are $100 - 4 = 96$ multiples of 4 between 2000 and 2399, inclusive, that are not also multiples of 100.

Thus, in total, there are $2 + 96 = 98$ leap years between 2000 and 2400, inclusive.



Problème de la semaine

Problème C

Aller-retour

Rory a parcouru 36 km à vélo sur un sentier depuis son emplacement de camping jusqu'à un belvédère. À l'aller, sa vitesse moyenne était de 9 km/h. Sur le chemin du retour, il a pédalé plus rapidement, sa vitesse moyenne était de 12 km/h. Quelle a été sa vitesse moyenne, en km/h, pour l'aller-retour ?





Problem of the Week

Problem C and Solution

Uphill and Downhill

Problem

Rory biked 36 km up a trail from his campsite to a lookout point. On the way up, his average speed was 9 km/hr. On the way back down, he biked faster, with an average speed of 12 km/hr. What was his average speed, in km/hr, for the entire trip?

Solution

First we calculate the time it took Rory to bike up to the lookout point and back down to his campsite.

Rory's 36 km ride up to the lookout point at 9 km/hr took $36 \div 9 = 4$ hrs.

Rory's 36 km ride back down to his campsite at 12 km/hr took $36 \div 12 = 3$ hrs.

Thus, the total time was $4 + 3 = 7$ hrs.

Rory's trip up to the lookout point and back down to his campsite had a total distance of $36 + 36 = 72$ km. Therefore, the average speed for the entire trip was $72 \div 7 \approx 10.3$ km/h.



Problème de la semaine

Problème C

Périodicité des éclipses

Sur une planète d'un système solaire lointain, dotée d'une lune et d'un soleil, se produit une éclipse solaire totale lorsque les conditions suivantes sont réunies:

- Il y a une pleine lune,
- la lune est au point le plus proche de la planète,
- le centre de la lune est aligné avec les centres de la planète et du soleil.

Sur cette planète, il y a une pleine lune tous les 16 jours. De plus, tous les 12 jours, la lune est au point le plus proche de la planète. De plus, tous les n jours, le centre de la lune est aligné avec les centres de la planète et du soleil.

Si n est supérieur à 10 mais inférieur à 20 et que les éclipses solaires totales se produisent sur cette planète tous les 240 jours, détermine la valeur de n .





Problem of the Week



Problem C and Solution

Cycles of Eclipses

Problem

A planet in a distant solar system has a moon and a sun. On this planet, there is a total solar eclipse whenever the following is true.

- There is a full moon,
- the moon is at its closest point to the planet, and
- the centre of the moon is in line with the centres of the planet and the sun.

On this planet, there is a full moon every 16 days. Also, every 12 days, the moon is at its closest point to the planet. As well, every n days the centre of the moon is in line with the centres of the planet and the sun.

If n is greater than 10 but less than 20, and total solar eclipses happen on this planet every 240 days, determine the value of n .

Solution

Since total solar eclipses happen every 240 days on this planet, it follows that 240 is the *least common multiple* (LCM) of 16, 12, and n .

To determine the value of n , we will rewrite each of 16, 12, and 240 as a product of prime numbers. This is known as *prime factorization*.

$$\begin{aligned}16 &= 2 \times 2 \times 2 \times 2 \\12 &= 2 \times 2 \times 3 \\240 &= 2 \times 2 \times 2 \times 2 \times 3 \times 5\end{aligned}$$

The LCM is calculated by determining the greatest number of each prime number in any of the factorizations, and then multiplying these numbers together. From the prime factorizations of 16 and 12, we can determine that their LCM is equal to $2 \times 2 \times 2 \times 2 \times 3 = 48$. Since 240 has an extra factor of 5, and 240 is the LCM of 16, 12, and n , it follows that 5 must be a factor of n . The only number with a factor of 5 that is greater than 10 but less than 20 is 15.

Since the prime factorization of 15 is $15 = 3 \times 5$, we can conclude that the LCM of 16, 12, and 15 is 240, as desired. Therefore $n = 15$.

EXTENSION: Research what conditions must occur for there to be a total solar eclipse on Earth. How often do total solar eclipses occur on Earth?



Problème de la semaine

Problème C

Expressions exponentielles

Voici deux expressions :

$$\text{Expression } A: 72 \times 7^x$$

$$\text{Expression } B: 441 \times 2^y$$

Etant donné que x et y sont des nombres entiers strictement positifs, trouve tous les couples (x, y) tels que la valeur de l'expression A soit égale à celle de l'expression B .

$$A=B$$



$$A=B$$

Problem of the Week

Problem C and Solution

Exponential Expressions

Problem

We are given two expressions:

$$\text{Expression } A: 72 \times 7^x$$

$$\text{Expression } B: 441 \times 2^y$$

Given that x and y are positive integers, find all ordered pairs (x, y) so that the value of Expression A is equal to the value of Expression B .

Solution

Solution 1

We write each expression as the product of prime numbers.

$$\text{Expression } A = (2^3)(3^2)(7^x) \text{ and Expression } B = (3^2)(7^2)(2^y).$$

Since x and y are each positive integers and the expressions are equal in value, then the corresponding exponents for each prime number must be equal.

Therefore, $x = 2$ and $y = 3$ is the only integer solution.

Thus, the only ordered pair is $(2, 3)$.

Solution 2

Setting the two expressions equal to each other, we have

$$72 \times 7^x = 441 \times 2^y$$

Dividing both sides by 9, we have

$$8 \times 7^x = 49 \times 2^y$$

Expressing each side of the equation as the product of prime numbers, we have

$$2^3 \times 7^x = 7^2 \times 2^y$$

Since x and y are each positive integers and the expressions are equal in value, then the corresponding exponents for each prime number must be equal.

Therefore, $x = 2$ and $y = 3$ is the only integer solution.

Thus, the only ordered pair is $(2, 3)$.



Problème de la semaine

Problème C

Effacer 1

Chetan écrit les entiers strictement positifs de 1 à 200 sur un tableau. Ensuite, Wassim efface tous les nombres qui sont des multiples de 9. Puis, Karla efface tous les nombres qui contiennent le chiffre 9. Combien reste-t-il de nombres sur le tableau ?



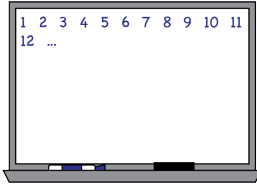

Problem of the Week

Problem C and Solution

Wipe Away 1

Problem

Chetan writes the positive integers from 1 to 200 on a whiteboard. Wassim then erases all the numbers that are multiples of 9. Karla then erases all the remaining numbers that contain the digit 9. How many numbers are left on the whiteboard?

Solution

We first calculate the number of integers that Wassim erases, which is the number of multiples of 9 between 1 and 200. Since $200 = (22 \times 9) + 2$, there are 22 multiples of 9 between 1 and 200. Thus, Wassim erases 22 numbers from the whiteboard.

Now let's figure out how many of the integers from 1 to 200 contain the digit 9. From 1 to 100, these numbers are 9, 19, ..., 79, 89 as well as 90, 91, ..., 98, 99. There are 19 of these numbers from 1 to 100. There are another 19 between 101 and 200, which are obtained by adding 100 to each of the numbers from 1 to 100. Therefore, $19 + 19 = 38$ integers from 1 to 200 contain the digit 9.

However, some of the integers that contain the digit 9 are also multiples of 9, so were erased by Wassim. There are 5 of these numbers between 1 and 200: 9, 90, 99, 189, and 198. Thus, Karla erases $38 - 5 = 33$ numbers from the whiteboard.

Hence, the number of numbers left on the whiteboard is $200 - 22 - 33 = 145$.