

Le CENTRE d'ÉDUCATION en  
MATHÉMATIQUES et en INFORMATIQUE

# Problème de la semaine

## Problèmes et solutions

### 2022 - 2023

(solutions disponibles en anglais seulement)

## Problème C (7<sup>e</sup>/8<sup>e</sup> année)

---

### Thèmes

(Cliquer sur le nom du thème ci-dessous pour sauter à cette section.)

**Sens du nombre (N)**

**Géométrie et mesure (G)**

**Algèbre (A)**

**Gestion des données (D)**

**Raisonnement informatiques (C)**

---

Les problèmes dans ce livret sont organisés par thème.

Un problème peut apparaître dans plusieurs thèmes.

---

# Sens du nombre (N)

---





## Problème de la semaine

### Problème C

#### Course farfelue

Quatre élèves participent en équipe à une course de relais farfelue de 1000 m. Dans cette course, les élèves parcourent chacun une partie de la distance de 1000 m et aucun d'eux ne parcourt la même distance qu'un autre. Andrea et Billie parcourent respectivement  $\frac{1}{8}$  et  $\frac{1}{5}$  de la distance totale. Carol parcourt une distance égale à la moyenne des distances parcourues par Andrea et Billie. Dana parcourt le reste de la distance.

Quelle fraction de la distance totale Dana a-t-elle parcourue?

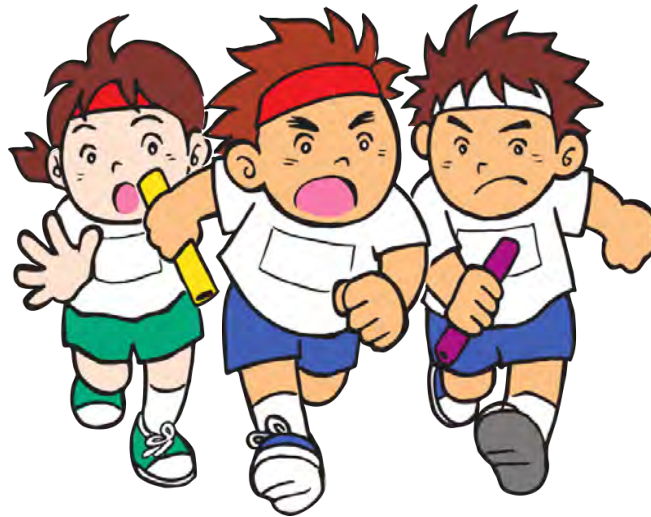



## Problem of the Week

### Problem C and Solution

#### Wacky Race

#### Problem

Four students participate as a team in a 1000 m wacky relay race. In a wacky relay race, the students each run a portion of the 1000 m length, but they do not run equal lengths. Andrea and Billie run  $\frac{1}{8}$  and  $\frac{1}{5}$  of the total length, respectively. Carol runs the average of what Andrea and Billie run. Dana runs the remainder of the length.

Determine the fraction of the total length that Dana runs.

#### Solution

In the first solution, we solve the problem by working with the fractions and without calculating the length that each person runs. In the second solution, we determine the fraction of the length that Dana runs by calculating the distance Dana runs and dividing by the total length of the race.

#### Solution 1

Carol runs the average of  $\frac{1}{8}$  and  $\frac{1}{5}$  of the total length of the race.

Therefore, Carol runs  $\frac{\frac{1}{8} + \frac{1}{5}}{2} = \frac{\frac{5}{40} + \frac{8}{40}}{2} = \frac{\frac{13}{40}}{2} = \frac{13}{80}$  of the race.

Dana runs the remainder of the race.

Therefore, Dana runs  $1 - \frac{1}{8} - \frac{1}{5} - \frac{13}{80} = \frac{80}{80} - \frac{10}{80} - \frac{16}{80} - \frac{13}{80} = \frac{41}{80}$  of the race. Dana runs just over half of the race.

#### Solution 2

Andrea runs  $\frac{1}{8}$  of the race, so she runs  $\frac{1}{8} \times 1000 = 125$  m.

Billie runs  $\frac{1}{5}$  of the race, so they run  $\frac{1}{5} \times 1000 = 200$  m.

Carol runs the average of what Andrea and Billie run.

Therefore, Carol runs  $\frac{125+200}{2} = \frac{325}{2} = 162.5$  m.

Dana runs the remainder of the race.

Therefore, Dana runs  $1000 - 125 - 200 - 162.50 = 512.5$  m.

That is, Dana runs  $\frac{512.5}{1000} = \frac{5125}{10000} = \frac{41}{80}$  of the race.



## Problème de la semaine

### Problème C

#### Deux carrés

Simone a une corde qui mesure 60 cm de long. Elle coupe la corde en deux parties de manière que les longueurs des deux bouts de cordes résultantes soient dans un rapport de 7 : 3. Chaque bout de corde est disposé de manière à former un carré (les deux extrémités de la corde étant donc reliées).

Quelle est l'aire totale des deux carrés?





## Problem of the Week

### Problem C and Solution

### Two Squares

#### Problem

Simone has a rope that is 60 cm long. They cut the rope into two pieces so that the ratio of the lengths of the two pieces is 7 : 3. Each piece of the rope is then arranged, with its two ends touching, to form a square.

What is the total area of the two squares?

#### Solution

Since the rope is cut in the ratio of 7 : 3, the ratio of the longer piece to the whole rope will be 7 : (7 + 3) or 7 : 10. This means the length of the longer piece will be  $\frac{7}{10}$  of the length of the whole rope. Similarly, the length of the shorter piece would be  $\frac{3}{10}$  of the length of the whole rope. Therefore, the longer piece is  $\frac{7}{10}$  of 60 or  $\frac{7}{10} \times 60 = 42$  cm long. Also, the shorter piece is  $\frac{3}{10}$  of 60 or  $\frac{3}{10} \times 60 = 18$  cm long.

Each of the two pieces is then used to form a square. The perimeter of each square is the length of the rope used to form it. The side length of the longer square is  $42 \div 4 = 10.5$  cm and the side length of the shorter square is  $18 \div 4 = 4.5$  cm.

To find the area of each square, we multiply the length by the width. In effect, to find the area of the square, we square the side length. Thus, the area of the larger square is  $10.5 \times 10.5 = 10.5^2 = 110.25$  cm<sup>2</sup> and the area of the smaller square is  $4.5 \times 4.5 = 4.5^2 = 20.25$  cm<sup>2</sup>.

Therefore, the total area of the two squares is  $110.25 + 20.25 = 130.5$  cm<sup>2</sup>.

#### FOR FURTHER THOUGHT:

The ratio of the area of the larger square to the area of the smaller square is

$$110.25 : 20.25 = 11025 : 2025 = 441 : 81 = 49 : 9 = 7^2 : 3^2$$

Notice that the ratio of the perimeter of the larger square to the perimeter of the smaller square is 7 : 3 and the ratio of their areas is  $7^2 : 3^2$ . In general, if the ratio of the perimeters of two squares is  $a : b$ , is it true that the ratio of the areas of the two squares is  $a^2 : b^2$ ?



## Problème de la semaine

### Problème C

#### Jouer avec des blocs

Agnes, Evangelina, Isabela, Omar et Yuri ont chacun fabriqué une tour avec des blocs en bois. Chaque personne a utilisé un nombre de blocs différent dans sa tour et il y avait, en moyenne, 25 blocs par tour. Yuri a utilisé le plus de blocs dans sa tour tandis qu'Agnès a utilisé le moins de blocs dans sa tour. Si Yuri a utilisé 32 blocs, détermine le nombre minimum possible de blocs qu'Agnès aurait pu utiliser.

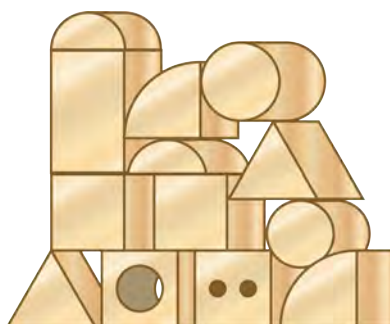

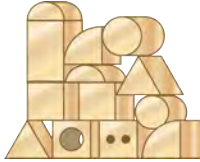

## Problem of the Week

### Problem C and Solution

#### Playing with Blocks

#### Problem

Agnes, Evangelina, Isabela, Omar, and Yuri each made a tower using wooden blocks. Each person used a different number of blocks in their tower, and the mean (average) number of blocks in each tower was 25. Yuri used the most blocks in her tower, and Agnes used the fewest blocks in her tower. If Yuri used 32 blocks, determine the minimum possible number of blocks that Agnes could have used.

#### Solution

To calculate the mean (average) of a set of values, we first calculate the sum of the values in the set, and then divide that by the number of values in the set. It follows that the sum of the values in the set is equal to their average multiplied by the number of values in the set.

Since the average number of blocks in each tower was 25, and there were 5 towers, it follows that the total number of blocks used was  $25 \times 5 = 125$ . Yuri's tower used 32 blocks, so the remaining towers used a total of  $125 - 32 = 93$  blocks.

To find the minimum possible number of blocks in Agnes' tower, we let the other three towers use the greatest possible number of blocks. We know Yuri's tower used the most blocks, and each tower used a different number of blocks. So the other three towers could have used at most 31, 30, and 29 blocks, in some order.

The minimum possible number of blocks that Agnes could have used is therefore  $93 - 31 - 30 - 29 = 3$ .

As a side note, if each person could have used the same number of blocks, then the minimum possible number of blocks that Agnes could have used would have been  $93 - 32 - 32 - 32 = -3$ . However it's not possible to use a negative number of blocks, so Agnes must have used at least 1 block. There would be a few different options for the number of blocks in each tower in order to make this possible. For example, the towers could contain 1, 28, 32, 32, and 32 blocks each, or 1, 30, 30, 32, and 32 blocks each.





## Problème de la semaine

### Problème C

#### Les dominos de Domi

Un domino est une tuile rectangulaire dont la face est divisée en deux carrés par une ligne. Chaque carré contient un certain nombre de points ou est vide.

Le premier domino illustré ci-dessous est un domino  $[3, 5]$  puisqu'il contient 3 points dans son carré gauche et 5 points dans son carré droit. Le deuxième domino illustré ci-dessous est un domino  $[0, 3]$  puisque son carré gauche est vide tandis que son carré droit contient 3 points. Le troisième domino illustré ci-dessous est un domino  $[4, 4]$  puisqu'il contient 4 points dans son carré gauche et 4 points dans son carré droit.

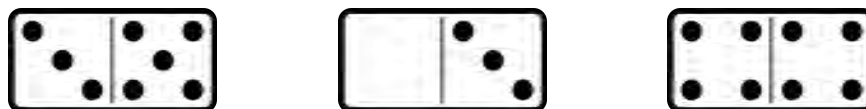

On peut également faire pivoter les dominos. Le premier domino illustré ci-dessous est un domino  $[5, 3]$  puisqu'il contient 5 points dans son carré gauche et 3 points dans son carré droit. Cependant, puisque ce domino peut être obtenu en faisant pivoter le domino  $[3, 5]$ , alors  $[5, 3]$  et  $[3, 5]$  représentent tous deux le même domino. De même, le deuxième domino illustré ci-dessous est un domino  $[3, 0]$ . Remarquons à nouveau que  $[3, 0]$  et  $[0, 3]$  représentent tous deux le même domino.

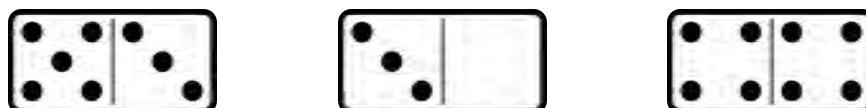

Un ensemble-2 de dominos contient tous les dominos dont le nombre de points dans chaque carré est de 0 à 2, deux dominos n'étant jamais identiques. Donc, un ensemble-2 de dominos contient les six dominos suivants:  $[0, 0]$ ,  $[0, 1]$ ,  $[0, 2]$ ,  $[1, 1]$ ,  $[1, 2]$ ,  $[2, 2]$ . Remarquons que les trois dominos  $[1, 0]$ ,  $[2, 0]$  et  $[2, 1]$  ne figurent pas dans la liste car ils sont identiques aux trois dominos  $[0, 1]$ ,  $[0, 2]$  et  $[1, 2]$ .

De même, un ensemble-12 de dominos contient tous les dominos dont le nombre de points dans chaque carré est de 0 à 12, deux dominos n'étant jamais identiques.

Domi a acheté un ensemble-12 de dominos. Combien de dominos y a-t-il dans cet ensemble?

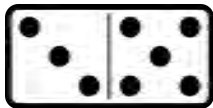

## Problem of the Week

### Problem C and Solution

#### Domi Knows

#### Problem

A domino tile is a rectangular tile with a line dividing its face into two square ends. Each end is marked with a number of dots (also called pips) or is blank.

The first domino shown below is a  $[3, 5]$  domino, since there are 3 pips on its left end and 5 pips on its right end. The second domino shown below is a  $[0, 3]$  domino, since there are 0 pips on its left end and 3 pips on its right end. The third domino shown below is a  $[4, 4]$  domino, since there are 4 pips on its left end and 4 pips on its right end.

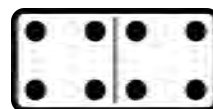
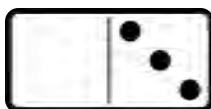
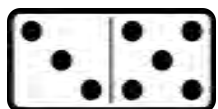

We can also rotate the domino tiles. The first domino shown below is a  $[5, 3]$  domino, since there are 5 pips on its left end and 3 pips on its right end. However, since this tile can be obtained by rotating the  $[3, 5]$  tile,  $[5, 3]$  and  $[3, 5]$  represent the same domino. Similarly, the second domino shown below is a  $[3, 0]$  domino. Again, note that  $[3, 0]$  and  $[0, 3]$  represent the same domino.

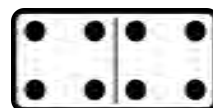
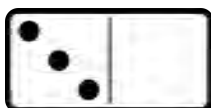
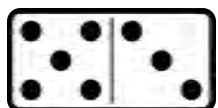

A 2-set of dominoes contains all possible tiles with the number of pips on any end ranging from 0 to 2, with no two dominoes being the same. A 2-set of dominoes has the following six tiles:  $[0, 0]$ ,  $[0, 1]$ ,  $[0, 2]$ ,  $[1, 1]$ ,  $[1, 2]$ ,  $[2, 2]$ . Notice that the three dominoes  $[1, 0]$ ,  $[2, 0]$ , and  $[2, 1]$  are not listed because they are the same as the three dominoes  $[0, 1]$ ,  $[0, 2]$ , and  $[1, 2]$ .

Similarly, a 12-set of dominoes contains all possible tiles with the number of pips on any end ranging from 0 to 12, with no two dominoes being the same.

Domi purchased a 12-set of dominoes. How many tiles are in the set?

#### Solution

Since rotating a domino tile does not change the domino, we will orient each domino so that the smaller number is always on the left end of the domino. Then, for each possible number on the left end of the domino, we will examine the possible numbers that can occur on the right end of the domino, and thus how many dominoes in the set have that number on the left end. We compile this information in a table.



Number on Left End of Domino	Possible Numbers on Right End of Domino	Total Number of Dominoes
0	0, 1, 2, 3, 4, 5, 6, 7, 8, 9, 10, 11, 12	13
1	1, 2, 3, 4, 5, 6, 7, 8, 9, 10, 11, 12	12
2	2, 3, 4, 5, 6, 7, 8, 9, 10, 11, 12	11
3	3, 4, 5, 6, 7, 8, 9, 10, 11, 12	10
4	4, 5, 6, 7, 8, 9, 10, 11, 12	9
5	5, 6, 7, 8, 9, 10, 11, 12	8
6	6, 7, 8, 9, 10, 11, 12	7
7	7, 8, 9, 10, 11, 12	6
8	8, 9, 10, 11, 12	5
9	9, 10, 11, 12	4
10	10, 11, 12	3
11	11, 12	2
12	12	1

Therefore, the total number of dominoes in a 12-set is

$$1 + 2 + 3 + 4 + 5 + 6 + 7 + 8 + 9 + 10 + 11 + 12 + 13 = 91$$

### DID YOU KNOW?

A quick way to calculate the sum

$$1 + 2 + 3 + 4 + 5 + 6 + 7 + 8 + 9 + 10 + 11 + 12 + 13$$

is as

$$\frac{(13)(13 + 1)}{2}$$

That is,  $1 + 2 + 3 + 4 + 5 + 6 + 7 + 8 + 9 + 10 + 11 + 12 + 13 = \frac{(13)(13 + 1)}{2}$ .

Can you convince yourself that this is true?

In general, it can be shown that if  $n$  is a positive integer, then the sum of the integers from 1 to  $n$  is equal to  $\frac{n \times (n + 1)}{2}$ .

In other words,

$$1 + 2 + 3 + \dots + n = \frac{n(n + 1)}{2}$$



## Problème de la semaine

### Problème C

#### Faire ses courses

Pendant qu'il fait ses courses, Terry estime le coût total de ses achats en estimant que chaque article coûtera 3,00 \$.

Un jour, Terry a acheté 20 articles. Chaque article qu'il a acheté coûtait soit 1,00 \$, soit 3,00 \$, soit 7,50 \$. Exactement sept des articles achetés coûtaient 3,00 \$. Si le coût total réel des 20 articles est le même que le coût total selon l'estimation de Terry, combien d'articles coûtaient 7,50 \$?





## Problem of the Week

### Problem C and Solution

### Gone Shopping

#### Problem

While grocery shopping, Terry has a way to approximate the total cost of his purchases. He simply approximates that each item will cost \$3.00.

One day, Terry purchased 20 items. He purchased items that each had an actual cost of either \$1.00, \$3.00, or \$7.50. Exactly seven of the purchased items had an actual cost of \$3.00. If the total actual cost of the 20 items was the same as the total approximated cost, how many items had an actual cost of \$7.50?

#### Solution

The total approximated cost for the 20 items is  $20 \times \$3 = \$60$ . Since the total actual cost is the same as the total approximated cost, the total actual cost for the 20 items is \$60. Since 7 of the items cost \$3.00, it cost Terry  $7 \times \$3 = \$21$  to buy these items. Therefore, the remaining  $20 - 7 = 13$  items cost  $\$60 - \$21 = \$39$ .

From this point, we will continue with two different solutions.

#### Solution 1

In this solution, we will use systematic trial-and-error to solve the problem.

Let  $s$  represent the number of items Terry bought with an actual cost of \$7.50 and  $d$  represent the number of items that Terry bought with an actual cost \$1.00. Then the total cost of the \$7.50 items would be  $7.5s$ . Also, the total cost of the \$1.00 items would be  $1d = d$ . Since Terry's total remaining cost was \$39, then  $7.5s + d = 39$ . We also know that  $s + d = 13$ .

At this point we can systematically pick values for  $s$  and  $d$  that add to 13 and substitute into the equation  $7.5s + d = 39$  to find the combination that works. (We can observe that  $s < 6$  since  $7.5 \times 6 = 45 > 39$ . If this were the case, then  $d$  would have to be a negative number.)

Let's start with  $s = 3$ . Then  $d = 13 - 3 = 10$ . The cost of these items would be  $7.5 \times 3 + 10 = 22.50 + 10 = \$32.50$ , which is less than \$39.

So let's try  $s = 4$ . Then  $d = 13 - 4 = 9$ . The cost of these items would be  $7.5 \times 4 + 9 = 30 + 9 = \$39$ , which is the amount we want.

Therefore, Terry purchased 4 items that cost \$7.50.



## Solution 2

In this solution, we will use algebra to solve the problem.

Let  $s$  represent the number of items that cost \$7.50. Therefore,  $(13 - s)$  represents the number of items that cost \$1.00. Also, the total cost of the \$7.50 items would be  $7.5s$ , the total cost of the \$1.00 items would be  $1 \times (13 - s) = 13 - s$ , and the total of these two is  $7.5s + 13 - s = 6.5s + 13$ .

Since Terry's total remaining cost was \$39.00, we must have

$$\begin{aligned}6.5s + 13 &= 39 \\6.5s + 13 - 13 &= 39 - 13 \\6.5s &= 26 \\ \frac{6.5s}{6.5} &= \frac{26}{6.5} \\s &= 4\end{aligned}$$

Therefore, Terry purchased 4 items that cost \$7.50.



## Problème de la semaine

### Problème C

#### Virée entre enseignants 1

Pour passer le temps lors d'un long trajet en bus, 35 enseignants de mathématiques ont créé une suite de nombres. À tour de rôle, chaque enseignant a dit un nombre de la suite. Le premier enseignant a dit le nombre 2, le deuxième enseignant a dit le nombre 8 et chaque enseignant après cela a dit la somme des deux termes précédents. Donc,

- le troisième enseignant a dit la somme des premier et deuxième termes, soit  $2 + 8 = 10$  et
- le quatrième enseignant a dit la somme des deuxième et troisième termes, soit  $8 + 10 = 18$ .

Après que le dernier enseignant a dit son nombre, le 25<sup>e</sup> enseignant a annoncé qu'il avait fait une erreur et que son nombre aurait dû être un de plus que celui qu'il avait dit. Quelle est la différence entre le nombre que le dernier enseignant a dit et celui qu'il aurait dit si le 25<sup>e</sup> enseignant n'avait pas fait d'erreur?





## Problem of the Week

### Problem C and Solution

#### Teacher Road Trip 1

#### Problem

To help pass time on a long bus ride, 35 math teachers created a sequence of numbers, with each teacher saying one term in the sequence. The first teacher said the number 2, the second teacher said the number 8, and every teacher after that said the sum of the two previous terms. Thus,

- the third teacher said the sum of the first and second terms, which is  $2 + 8 = 10$ , and
- the fourth teacher said the sum of the second and third terms, which is  $8 + 10 = 18$ .

Once the final teacher said their number, the 25<sup>th</sup> teacher announced they had made a mistake and their number should have been one more than what they had said. How much larger should the final teacher's number have been?

#### Solution

##### Solution 1

We will write out the sequence of numbers the teachers actually said, and then the sequence of numbers they should have said, and then find the difference between the last term in each sequence.

Here are the first 24 numbers that the teachers said:

2, 8, 10, 18, 28, 46, 74, 120, 194, 314, 508, 822, 1330, 2152, 3482, 5634, 9116, 14750, 23866, 38616, 62482, 101098, 163580, 264678

Here are the correct 25<sup>th</sup> to 35<sup>th</sup> numbers that the teachers should have said:

428258, 692936, 1121194, 1814130, 2935324, 4749454, 7684778, 12434232, 20119010, 32553242, 52672252

Here are the 25<sup>th</sup> to 35<sup>th</sup> numbers that the teachers actually said:

428257, 692935, 1121192, 1814127, 2935319, 4749446, 7684765, 12434211, 20118976, 32553187, 52672163

The difference between the correct and incorrect 35<sup>th</sup> number is  $52672252 - 52672163 = 89$ . Therefore, the 35<sup>th</sup> number was off by 89, and so the final teacher's number should have been 89 larger than the number they had said.





## Solution 2

In this solution we will solve the problem without actually calculating all the terms in the sequence.

We know the 25<sup>th</sup> term is off by 1. Therefore, the next terms will be as follows.

- The 26<sup>th</sup> term will also be off by 1 since it equals the sum of the 24<sup>th</sup> term (which is unchanged) and the 25<sup>th</sup> term (which is off by 1).
- The 27<sup>th</sup> term will be off by 2 since it is the sum of the 25<sup>th</sup> term (which is off by 1) and the 26<sup>th</sup> term (which is off by 1).
- The 28<sup>th</sup> term will be off by 3 since it is the sum of the 26<sup>th</sup> term (which is off by 1) and the 27<sup>th</sup> term (which is off by 2).

This pattern will continue on, so we can summarize it in a table.

Term Number	Amount Below the Correct Value
24	0
25	1
26	1
27	2
28	3
29	5
30	8
31	13
32	21
33	34
34	55
35	89

Therefore, the 35<sup>th</sup> term was off by 89, and so the final teacher's number should have been 89 larger than the number they had said.

Notice that the terms in the right column of the table follow the same rule as the original question. That is, each term is the sum of the previous two terms.

**FOR FURTHER THOUGHT:** The last 11 numbers in the right column of the table are the first 11 numbers of a famous sequence known as the Fibonacci Sequence. You may wish to investigate the Fibonacci Sequence further.



## Problème de la semaine

### Problème C

#### Diviseurs et nombres

Ton ami Cael aime toujours te lancer des défis. L'un de ces défis s'appelle "*Diviseurs et nombres*". Cael te dira certaines informations à propos des diviseurs d'un nombre et te mettra ensuite au défi de trouver ce nombre. Voici le défi de Cael.

"Je cherche un entier strictement positif qui admet exactement huit diviseurs positifs, dont deux sont 21 et 33."

Détermine le nombre de Cael.





## Problem of the Week

### Problem C and Solution

### Divisors and Number

#### Problem

Your friend Cael always likes challenging you. One challenge is called “*Divisors and Number*”. Cael will tell you certain facts about the divisors of a number and then challenge you to find the number. Here is Cael’s challenge.

“I am looking for a positive integer with exactly eight positive divisors, two of which are 21 and 33.”

Determine Cael’s number.

#### Solution

Let  $n$  represent the number we are looking for.

We know that four of the positive divisors of  $n$  are 1, 21, 33, and  $n$ . In our solution we will first find the remaining four positive divisors and then determine  $n$ .

Since 21 is a divisor of  $n$  and  $21 = 3 \times 7$ , then 3 and 7 must also be divisors of  $n$ .

Since 33 is a divisor of  $n$  and  $33 = 3 \times 11$ , then 11 must also be a divisor of  $n$ .

Since 7 is a divisor of  $n$  and 11 is a divisor of  $n$ , and since 7 and 11 have no common divisors, then  $7 \times 11 = 77$  must also be a divisor of  $n$ .

We have found all eight of the positive divisors of the unknown number. The positive divisors are 1, 3, 7, 11, 21, 33, 77, and  $n$ . We now need to determine  $n$ .

From the list of divisors, we can see that the prime factors of  $n$  are 3, 7, and 11. It follows that  $n = 3 \times 7 \times 11 = 231$ .

Therefore, Cael’s number is 231.



## Problème de la semaine

### Problème C

#### Deux briques

Dhvanil possède plusieurs cartes. Au verso de chaque carte, il y a soit un motif en alvéoles de miel (hexagones), soit un motif en briques (rectangles). Au recto de chaque carte, il y a soit un 1, soit un 2. En examinant toutes les cartes, Dhvanil a constaté que 30 % des cartes ont un motif en alvéoles de miel au verso. Parmi les cartes ayant un motif en briques au verso, 80 % ont un 1 au recto.

Quel pourcentage des cartes ont un motif en briques au verso et un 2 au recto?

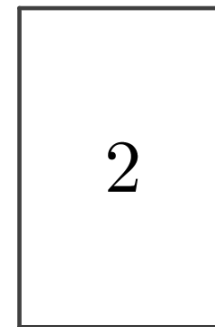
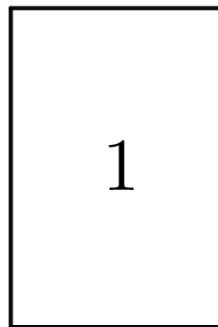
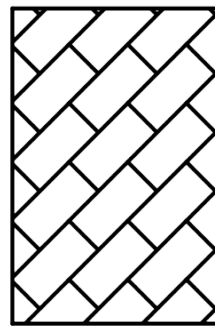
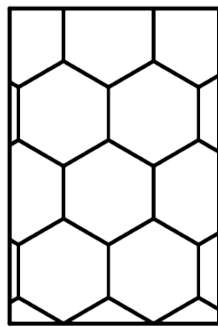

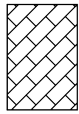
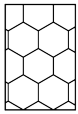

## Problem of the Week

### Problem C and Solution

#### Two Bricks

#### Problem

Dhvanil has a large number of cards. On the back of each card there is either a honeycomb pattern (hexagons) or a brick pattern (rectangles). On the front of each card there is either a 1 or a 2. As Dhvanil went through all the cards, he found that 30% of the cards have a honeycomb pattern on the back. Of the cards with a brick pattern on the back, 80% have a 1 on the front.

Determine the percentage of all the cards that have a brick pattern on the back and a 2 on the front.

#### Solution

##### Solution 1

Let's suppose that Dhvanil has 100 cards.

If 30% of the cards have a honeycomb pattern on the back, that means that  $0.3 \times 100 = 30$  cards have a honeycomb pattern on the back. Therefore,  $100 - 30 = 70$  cards have a brick pattern on the back.

Of the cards with a brick pattern on the back, 80% have a 1 on the front. Therefore, there are  $0.8 \times 70 = 56$  cards with a brick pattern on the back and 1 on the front. Therefore,  $70 - 56 = 14$  cards have a brick pattern on the back and a 2 on the front.

Therefore, the percentage of all cards with a brick pattern on the back and a 2 on the front is  $\frac{14}{100} \times 100\% = 14\%$ .

##### Solution 2

If 30% of the cards have a honeycomb pattern on the back, that means that 70% of the cards have a brick pattern on the back.

Of the cards with a brick pattern on the back, 80% have a 1 on the front. Therefore, of the cards with a brick pattern on the back, 20% have a 2 on the front. Since  $0.2 \times 0.70 = 0.14$ , 14% of all of the cards have a brick pattern on the back and a 2 on the front.



## Problème de la semaine

### Problème C

#### Quel est le pointage?

Dans le cours d'éducation physique, l'équipe jaune et l'équipe bleue ont joué au soccer. Ali ne se souvient pas du pointage final du match, mais elle a les renseignements suivants:

- Six buts ont été marqués au total.
- Aucune équipe n'a marqué plus de deux buts d'affilée à un moment donné du match.
- L'équipe bleue a remporté le match.

Détermine tous les pointages finaux possibles et les manières différentes dont chaque pointage aurait pu être obtenu.





## Problem of the Week

### Problem C and Solution

#### What's the Score?

#### Problem

In gym class, the yellow team and the blue team played soccer. Ali doesn't remember the final score of the game, but she does remember the following.

- There were six goals scored in total.
- Neither team scored more than two goals in a row at any point in the game.
- The blue team won the game.

Determine all the possible final scores and the different ways each score could have been obtained.

#### Solution

In order to win, the blue team must have scored more goals than the yellow team. Since there were six goals scored in total, the only possibilities for the final scores are  $4 - 2$ ,  $5 - 1$ , or  $6 - 0$  for the blue team.

Next we need to check which of these scores are possible, given that neither team scored more than two goals in a row at any point in the game.

- Is a final score of  $6 - 0$  possible?

We can easily eliminate  $6 - 0$ , since the blue team would have had to score more than two goals in a row.

- Is a final score of  $5 - 1$  possible?

This would mean that the blue team scored 5 goals and the yellow team scored 1 goal. Is there a way to arrange these goals so that the blue team didn't score two goals in a row? Let's look at all the possible arrangements, where  $B$  represents a goal for the blue team, and  $Y$  represents a goal for the yellow team. These are all shown below.

$YBBBBB$ ,  $BYBBBB$ ,  $BBYBBB$ ,  $BBBYBB$ ,  $BBBBYB$ ,  $BBBBBY$

As we can see, in all of these arrangements, the blue team scored more than two goals in a row. Thus, a final score of  $5 - 1$  is not possible.



- Is a final score of  $4 - 2$  possible?

This would mean that the blue team scored 4 goals and the yellow team scored 2 goals. Is there a way to arrange these goals so that the blue team didn't score two goals in a row? Let's look at all the possible arrangements, where  $B$  represents a goal for the blue team, and  $Y$  represents a goal for the yellow team.

- Case 1: The yellow team scored their 2 goals in a row. The possible arrangements are shown below.

*YYBBBB, BYYBBB, BBYYBB, BBBYYB, BBBBY*

In this case, there is only 1 arrangement where neither team scored more than two goals in a row, namely *BBYYBB*.

- Case 2: The yellow team did not score their 2 goals in a row. The possible arrangements are shown below.

*YBYBBB, YBBYBB, YBBBYB, YBBBBY, BYBYBB, BYBBYB, BYBBBY, BBYBYB, BBYBBY, BBBYBY*

In this case, there are 5 arrangements where neither team scored more than two goals in a row, namely

*YBBYBB, BYBYBB, BYBBYB, BBYBYB, and BBYBBY*.

Therefore, the only possible final score is  $4 - 2$  for the blue team, and it could be obtained in the following six ways.

*BBYYBB, YBBYBB, BYBYBB, BYBBYB, BBYBYB, BBYBBY*





## Problème de la semaine

### Problème C

#### Encore et encore

La fraction  $\frac{1}{7}$  est égale au nombre périodique  $0,\overline{142857}$ .

Quel chiffre se trouve à la 2023<sup>e</sup> position après la virgule décimale?

0.142857142857142...



## Problem of the Week

### Problem C and Solution

### Again and Again

0.142857142857142...

#### Problem

The fraction  $\frac{1}{7}$  is equal to the repeating decimal  $0.\overline{142857}$ .

Which digit occurs in the 2023<sup>rd</sup> place after the decimal point?

#### Solution

The digits after the decimal point occur in repeating blocks of the 6 digits 142857.

Since  $\frac{2023}{6} = 337.\overline{16} = 337\frac{1}{6}$ , it follows that the 2023<sup>rd</sup> digit after the decimal point occurs after 337 complete repeating blocks of the 6 digits.

In 337 complete repeating blocks, there are  $337 \times 6 = 2022$  digits in total. The 2023<sup>rd</sup> digit is then the next digit. This corresponds to the first digit in the repeating block, which is 1.

Therefore, the digit 1 occurs in the 2023<sup>rd</sup> place after the decimal point.



## Problème de la semaine

### Problème C

#### Drôle de glacière

Une boîte métallique en forme de prisme droit à base rectangulaire a une base dont les dimensions sont de  $18\text{ cm} \times 22\text{ cm}$  et une hauteur de  $77\text{ cm}$ . La boîte doit être remplie d'eau, qui sera ensuite congelée. Lorsque l'eau gèle, elle se dilate d'environ  $10\%$ . Détermine la profondeur maximale à laquelle on peut remplir la boîte d'eau pour que la glace ne dépasse pas le haut du récipient lorsque l'eau gèle.

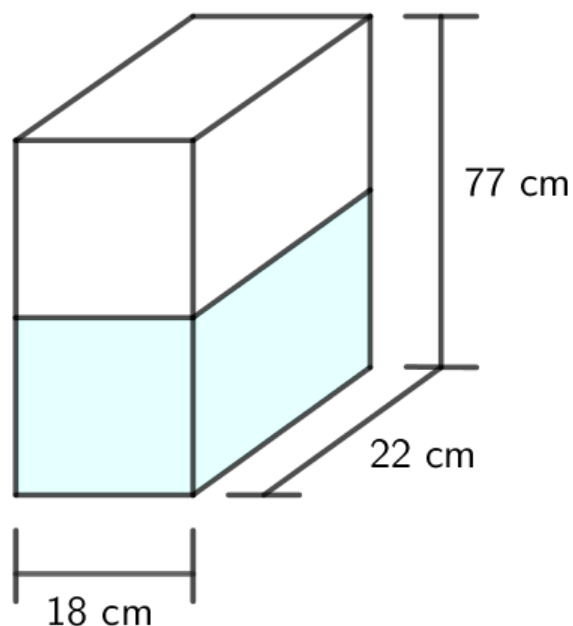

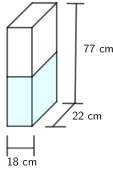

## Problem of the Week

### Problem C and Solution

#### Ice Box

#### Problem

A metal box in the form of a rectangular prism has an 18 cm by 22 cm base and a height of 77 cm. The box is to be filled with water, which will then be frozen. When water freezes it expands by approximately 10%. Determine the maximum depth to which the box can be filled with water so that when the water freezes, the ice does not go above the top of the container.

#### Solution

##### Solution 1

To determine the volume of a rectangular prism, we multiply its length, width, and height together. So, the maximum volume of the metal box is

$$18 \times 22 \times 77 = 30\,492 \text{ cm}^3$$

Let the original depth of water in the metal box be  $h$  cm.

The water volume before freezing is  $18 \times 22 \times h = (396 \times h) \text{ cm}^3$ . After the water freezes, the volume increases by 10% to 110% of its current volume. That is, after freezing the volume is

$$110\% \text{ of } 396 \times h = 1.1 \times 396 \times h = (435.6 \times h) \text{ cm}^3$$

But the volume after freezing is the maximum volume,  $30\,492 \text{ cm}^3$ . Therefore,  $435.6 \times h = 30\,492$  and it follows that  $h = 30\,492 \div 435.6 = 70$  cm.

Therefore, the maximum depth to which the box can be filled is 70 cm.

##### Solution 2

In this solution we note that the length and width remain the same in the volume calculations before and after the water freezes. We need only concern ourselves with the change in the depth of the water.

Let the original depth of water in the container be  $h$  cm.

After freezing, the depth increases by 10% to 110% of its depth before freezing. So, after freezing the depth will be 110% of  $h = 1.1 \times h = 77$  cm, the maximum height of the container. Then  $h = 77 \div 1.1 = 70$  cm.

Therefore, the maximum depth to which the box can be filled is 70 cm.



## Problème de la semaine

### Problème C

#### Retour en arrière

Gwen a obtenu le pouvoir de voyager dans le temps en marchant le long de trois sentiers différents. Elle peut marcher sur n'importe quel sentier aussi souvent qu'elle le souhaite, mais ne peut marcher que sur un sentier à la fois. Elle doit marcher sur les sentiers en respectant les règles suivantes:

- Lorsqu'elle marche sur le sentier A, elle doit faire 7 pas en avant. Cela lui permettra de remonter de 4 mois dans le temps.
- Lorsqu'elle marche sur le sentier B, elle doit faire 5 pas en arrière. Cela lui permettra de remonter de 7 mois dans le temps.
- Lorsqu'elle marche sur le sentier C, elle doit faire 2 pas en avant. Cela lui permettra de remonter de 3 mois dans le temps.

Un jour, elle remonte de 5 ans dans le temps. Elle a fait un total de 25 pas en arrière et a marché sur les trois sentiers 12 fois au total. Combien de pas en avant a-t-elle fait?

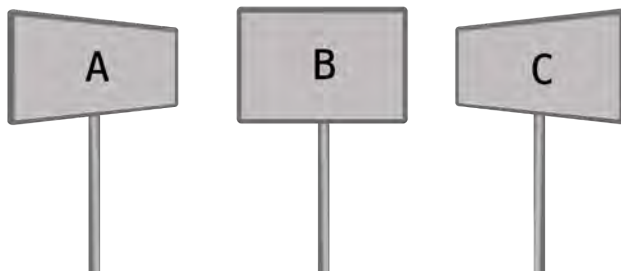

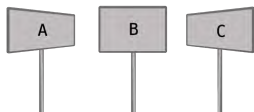

## Problem of the Week

### Problem C and Solution

#### Go Back

#### Problem

Gwen has been given the ability to time travel by walking along three different trails. She can walk on any trail as often as she wishes, but can only walk on one trail at a time. She must walk on the trails using the following rules.

- When she walks on Trail A, she must take 7 steps forward. This will allow her to travel 4 months backward in time.
- When she walks on Trail B, she must take 5 steps backward. This will allow her to travel 7 months backward in time.
- When she walks on Trail C, she must take 2 steps forward. This will allow her to travel 3 months backward in time.

One day she travels 5 years into the past. She made a total of 25 steps backward and walked on the three trails a total of 12 times. How many steps forward did she take?

#### Solution

Gwen travelled 5 years back in time, which is equivalent to travelling  $5 \times 12 = 60$  months back in time.

Trail B is the only trail that requires that she step backward. For every 5 steps backward, she travels 7 months back in time. Therefore, for 25 steps backward, she used Trail B  $25 \div 5 = 5$  times and travelled back in time  $5 \times 7 = 35$  months.

She still needs to travel  $60 - 35 = 25$  more months back in time. She has used Trail B 5 times, and since she uses the trails a total of 12 times, she has  $12 - 5 = 7$  trail uses left. She can now only use Trail A and Trail C. We will present two solutions from this point.

#### Solution 1

If Gwen uses Trail A and Trail C one time each, she travels a total of 7 months back in time. If she uses Trail A and Trail C three times each, this accounts for six uses and she travels a total of  $7 \times 3 = 21$  months back in time. She has one use left and still needs to travel 4 more months back in time. This can be accomplished by using Trail A once more.

It follows that Trail A is used 4 times and Trail C is used 3 times. The total number of forward steps is  $4 \times 7 + 3 \times 2 = 28 + 6 = 34$ .

Note that we could also have looked at each of the possibilities for using Trail A. Since there are a total of 7 trail uses for Trails A and C, the minimum number of uses for Trail A would be 0 and the maximum number of uses for Trail A would be 7. Once the number of uses for Trail A is selected, the number of uses for Trail C can be determined by subtracting the number of uses for Trail A from 7. For each combination we could determine the number of months travelled back in time. Once the correct combination is determined the total number of forward steps can be calculated. This is summarized in a table.



Uses of Trail A	Uses of Trail C	Months Travelled Back in Time
0	7	$0 \times 4 + 7 \times 3 = 0 + 21 = 21$
1	6	$1 \times 4 + 6 \times 3 = 4 + 18 = 22$
2	5	$2 \times 4 + 5 \times 3 = 8 + 15 = 23$
3	4	$3 \times 4 + 4 \times 3 = 12 + 12 = 24$
4	3	$4 \times 4 + 3 \times 3 = 16 + 9 = 25$
5	2	$5 \times 4 + 2 \times 3 = 20 + 6 = 26$
6	1	$6 \times 4 + 1 \times 3 = 24 + 3 = 27$
7	0	$7 \times 4 + 0 \times 3 = 28 + 0 = 28$

Only one combination gives the correct number of trail uses and the correct number of months travelled back in time. Using only Trail A and Trail C a total of 7 times, if we want to travel back in time 25 months we need to use Trail A 4 times and Trail C 3 times. The total number of forward steps is  $4 \times 7 + 3 \times 2 = 28 + 6 = 34$ .

### Solution 2

This solution is presented for you to get a glimpse of what is coming in future mathematics courses.

Let  $a$  be the number of uses of Trail A,  $b$  be the number of uses of Trail B, and  $c$  be the number of uses of Trail C. Since the total number of uses is 12, then  $a + b + c = 12$ .

The total number of backward steps is 25 and Trail B is the only trail requiring backward steps. Since each use of Trail B requires 5 backward steps, then we require a total of 5 uses of Trail B to go back 25 steps. It follows that  $b = 5$  and the equation  $a + b + c = 12$  becomes  $a + 5 + c = 12$ , which simplifies to  $a + c = 7$ .

In using Trail B 5 times, Gwen travels a total of  $5 \times 7 = 35$  months back in time. She needs to travel a total of 5 years or 60 months back in time. Thus, using Trail A and Trail C, she needs to travel  $60 - 35 = 25$  more months back in time. Since she travels 4 months backward with each use of Trail A and 3 months backward with each use of Trail C, we need  $4a + 3c = 25$ .

Rearranging the equation  $a + c = 7$ , we obtain  $c = 7 - a$ . We can substitute for  $c$  in the equation  $4a + 3c = 25$ .

$$\begin{aligned}4a + 3c &= 25 \\4a + 3(7 - a) &= 25 \\4a + 21 - 3a &= 25 \\a + 21 &= 25 \\a &= 4\end{aligned}$$

We can substitute  $a = 4$  into the equation  $a + c = 7$  to determine that  $c = 3$ .

For each use of Trail A, 7 forward steps are required. Therefore, Gwen steps forward  $7a$  steps using Trail A. For each use of Trail C, 2 forward steps are required. Therefore, Gwen steps forward  $2c$  steps using Trail C. The total number of steps forward is  $7a + 2c$ . Since  $a = 4$  and  $c = 3$ , the total number of forward steps is  $7(4) + 2(3) = 28 + 6 = 34$ .



## Problème de la semaine

### Problème C

### Cinq exclus I

Bobbi écrit la liste des nombres entiers positifs, en ordre croissant, tout en excluant tous les multiples de 5. Elle écrit donc la liste suivante:

1, 2, 3, 4, 6, 7, 8, 9, 11, 12, 13, 14, 16, 17, ...

Combien de nombres entiers Bobbi a-t-elle écrits juste avant d'exclure le 2023<sup>e</sup> multiple de 5 ?

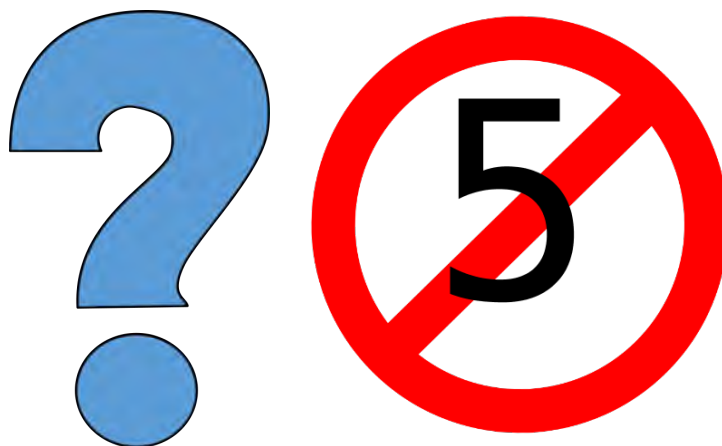





## Problem of the Week

### Problem C and Solution

#### Missing the Fives I

#### Problem

Bobbi lists the positive integers, in order, excluding all multiples of 5. Her resulting list is

$$1, 2, 3, 4, 6, 7, 8, 9, 11, 12, 13, 14, 16, 17, \dots$$

How many integers has Bobbi listed just before she leaves out the 2023rd multiple of 5?

#### Solution

##### Solution 1

In the list of integers beginning at 1, the 2023th multiple of 5 is  $2023 \times 5 = 10\,115$ . Thus, Bobbi has listed each of the integers from 1 to 10 114 with the exception of the positive multiples of 5 less than 10 115. Since 10 115 is the 2023rd multiple of 5, Bobbi will not write 2022 multiples of 5.

Therefore, just before Bobbi leaves out the 2023rd multiple of 5, she has listed  $10\,114 - 2022 = 8092$  integers.

##### Solution 2

Beginning at 1, each group of five integers has one integer that is a multiple of 5. For example, the first group of five integers, 1, 2, 3, 4, 5, has one multiple of 5 (namely 5), and the second group of five integers, 6, 7, 8, 9, 10, has one multiple of 5 (namely 10). In Bobbi's list of integers, she leaves out the integers that are multiples of 5, and so in every group of five integers, Bobbi lists four of these integers. Thus, just before Bobbi leaves out the 2023rd multiple of 5, there were 2023 of these groups. Therefore, she has listed  $2023 \times 4 = 8092$  integers.



## Problème de la semaine

### Problème C

#### Maison de poupée

Le premier étage d'une maison de poupée a la forme d'un rectangle. Son plan est illustré dans la figure suivante.

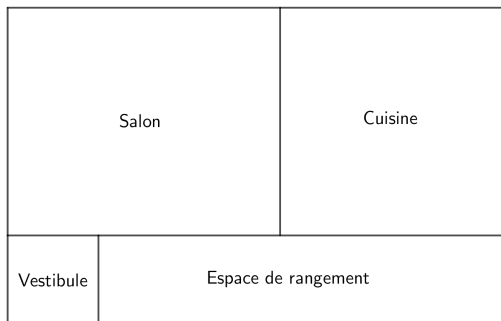

Le vestibule et la cuisine sont tous deux carrés et ont respectivement des aires de  $400 \text{ cm}^2$  et  $2500 \text{ cm}^2$ . Le salon est rectangulaire et a une aire de  $3000 \text{ cm}^2$ .

Détermine l'aire de l'espace de rangement rectangulaire.



# Problem of the Week

## Problem C and Solution

### Dollhouse

#### Problem

The first level of a dollhouse is in the shape of a rectangle. Its floor plan is shown in the following diagram.

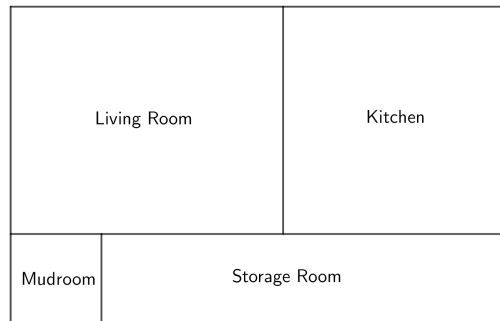

Both the mudroom and the kitchen are square with areas of  $400 \text{ cm}^2$  and  $2500 \text{ cm}^2$ , respectively. The living room is rectangular with an area of  $3000 \text{ cm}^2$ .

Determine the area of the rectangular storage room.

#### Solution

Let the width of a room be the vertical length of the room on the diagram. Let the length of a room be the horizontal length of the room on the diagram.

The kitchen is a square and has an area of  $2500 \text{ cm}^2$ . Its length and width must both be  $50 \text{ cm}$  since  $50 \times 50 = 2500 \text{ cm}^2$ . The living room and kitchen have the same width. So the width of the living room must also be  $50 \text{ cm}$ . But the area of the living room is  $3000 \text{ cm}^2$ , so the length of the living room is  $60 \text{ cm}$  since  $50 \times 60 = 3000 \text{ cm}^2$ .

The mudroom is a square and has an area of  $400 \text{ cm}^2$ . Its length and width must both be  $20 \text{ cm}$  since  $20 \times 20 = 400 \text{ cm}^2$ . The mudroom and storage room have the same width. So the width of the storage room must also be  $20 \text{ cm}$ .

Now the length of the whole house can be calculated in two ways. We will equate these two expressions to find the length of the storage room.

$$\begin{aligned}\text{mudroom length} + \text{storage room length} &= \text{living room length} + \text{kitchen length} \\ 20 + \text{storage room length} &= 60 + 50 \\ 20 + \text{storage room length} &= 110 \\ \text{storage room length} &= 90 \text{ cm}\end{aligned}$$

Since the width of the storage room is  $20 \text{ cm}$  and the length of the storage room is  $90 \text{ cm}$ , the area of the storage room is  $20 \times 90 = 1800 \text{ cm}^2$ .



## Problème de la semaine

### Problème C

#### À vue d'oeil

Deux bateaux s'éloignent l'un de l'autre dans des directions opposées. Un bateau se déplace vers l'est à une vitesse constante de 8 km/h tandis que l'autre se déplace vers l'ouest à une vitesse constante différente.

À un moment donné, le bateau qui se déplace vers l'est se trouvait à 200 m à l'est du bateau qui se déplace vers l'ouest. Cependant, 15 minutes plus tard, les deux bateaux se perdent de vue.

Sachant que la visibilité en mer ce jour-là était de 5 km, détermine la vitesse constante du bateau qui se déplace vers l'ouest.

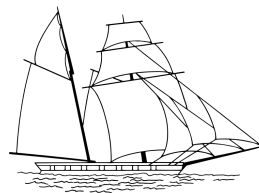
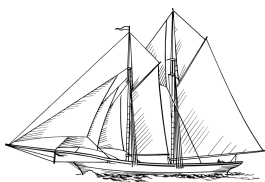

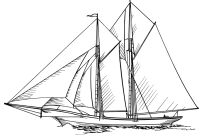

## Problem of the Week

### Problem C and Solution

### See You No More



#### Problem

Two boats are travelling away from each other in opposite directions. One boat is travelling east at the constant speed of 8 km/h and the other boat is travelling west at a different constant speed.

At one point, the boat travelling east was 200 m east of the boat travelling west, but 15 minutes later they lose sight of each other.

If the visibility at sea that day was 5 km, determine the constant speed of the boat travelling west.

#### Solution

We will call the boat travelling east Boat  $A$ , and the boat travelling west Boat  $B$ .

Boat  $A$  is travelling at a constant speed of 8 km/h.

Using the formula, distance = speed  $\times$  time, in 15 minutes Boat  $A$  will travel  $8 \frac{\text{km}}{\text{h}} \times \frac{15}{60} \text{ h} = 2 \text{ km}$ .

The visibility at sea is 5 km. Thus, Boat  $A$  and Boat  $B$  will be in sight of one another until they are 5 km apart. We are given that Boat  $A$  and Boat  $B$  are in sight of one another for 15 minutes. Thus, after 15 minutes Boat  $A$  and Boat  $B$  must be 5 km apart.

Since Boat  $A$  and Boat  $B$  start out 200 m = 0.2 km apart and Boat  $A$  travels 2 km in 15 minutes, Boat  $B$  must travel  $5 - 0.2 - 2 = 2.8 \text{ km}$  in 15 minutes.

Since Boat  $B$  travelled 2.8 km in 15 minutes, using the formula speed = distance  $\div$  time, Boat  $B$  must have been travelling at a speed of  $2.8 \text{ km} \div \frac{15}{60} \text{ h} = 2.8 \times \frac{60}{15} = 11.2 \text{ km/h}$ .

Therefore, Boat  $B$  was travelling at a speed of 11.2 km/h.



## Problème de la semaine

### Problème C

#### Garder la moyenne

Jackie construit une suite de six nombres en utilisant les règles suivantes.

1. Pour les deux premiers nombres, elle choisit deux nombres quelconques.
2. Chacun des quatre nombres suivants est la moyenne des deux nombres précédents.

Après avoir construit la suite, elle dit à son ami que le quatrième nombre est 22 et que le sixième nombre est 45. Quels sont les deux premiers nombres qu'elle a choisis ?

?	?	?	22	?	45
---	---	---	----	---	----



## Problem of the Week

?	?	?	22	?	45
---	---	---	----	---	----

### Problem C and Solution

#### Keep The Average

##### Problem

Jackie is making a sequence of six numbers using the following rules.

1. She chooses any two numbers for the first two numbers.
2. The next four numbers are each the average of the previous two numbers.

After she creates the sequence, she tells her friend that the fourth number is 22 and the sixth number is 45. What numbers did Jackie choose for the first two numbers?

##### Solution

We give two solutions. Both will use the fact that if  $x$  is the average of two numbers  $y$  and  $z$ , then  $\frac{y+z}{2} = x$ , and it follows that  $y + z = 2 \times x$ .

##### Solution 1

In the first solution, we solve the problem by working backwards.

Since the sixth number in the sequence is equal to the average of the two previous numbers, the sixth number must be the average of the fourth and fifth numbers. So, the sum of the fourth and fifth numbers must be 2 times the sixth number, or  $2 \times 45 = 90$ . Therefore, the fifth number is  $90 - 22 = 68$ .

We now determine the third number. The fifth number in the sequence is the average of the third and fourth numbers. So, the sum of the third and fourth numbers is 2 times the fifth number, or  $2 \times 68 = 136$ . Therefore, the third number is  $136 - 22 = 114$ .

We now determine the second number. The fourth number in the sequence is the average of the second and third numbers. So, the sum of the second and third numbers is 2 times the fourth number, or  $2 \times 22 = 44$ . Therefore, the second number is  $44 - 114 = -70$ .

We now determine the first number. The third number in the sequence is the average of the first and second numbers. So, the sum of the first and second numbers is 2 times the third number, or  $2 \times 114 = 228$ . Therefore, the first number is  $228 - (-70) = 228 + 70 = 298$ .

Therefore, the first number is 298 and the second number is  $-70$ .



## Solution 2

We will now present a similar, but more algebraic solution.

Let  $a$  represent the first number in the sequence,  $b$  represent the second number in the sequence,  $c$  represent the third number in the sequence, and  $d$  represent the fifth number in the sequence. We again solve this problem by working backwards.

Since the sixth number in the sequence is equal to the average of the fourth and fifth numbers, we have  $45 = \frac{22+d}{2}$ . Multiplying both sides by 2, we obtain  $22 + d = 45 \times 2 = 90$ . Rearranging,  $d = 90 - 22 = 68$ . Therefore, the fifth number in the sequence is 68.

We now determine the third number. Since the fifth number in the sequence is equal to the average of the third and fourth numbers, we have  $68 = \frac{c+22}{2}$ . Multiplying both sides by 2, we obtain  $c + 22 = 68 \times 2 = 136$ . Rearranging,  $c = 136 - 22 = 114$ . Therefore, the third number in the sequence is 114.

We now determine the second number. Since the fourth number in the sequence is equal to the average of the second and third numbers, we have  $22 = \frac{b+114}{2}$ . Multiplying both sides by 2, we obtain  $b + 114 = 22 \times 2 = 44$ . Rearranging,  $b = 44 - 114 = -70$ . Therefore, the second number in the sequence is  $-70$ .

We now determine the first number. Since the third number in the sequence is equal to the average of the first and second numbers, we have  $114 = \frac{a+(-70)}{2}$ . Multiplying both sides by 2, we obtain  $a + (-70) = 114 \times 2 = 228$ . Rearranging,  $a = 228 + 70 = 298$ . Therefore, the first number in the sequence is 298.

Therefore, the first number is 298 and the second number is  $-70$ .

298	-70	114	22	68	45
-----	-----	-----	----	----	----





## Problème de la semaine

### Problème C

#### Six zéros

Le produit des sept premiers nombres entiers strictement positifs est égal à

$$7 \times 6 \times 5 \times 4 \times 3 \times 2 \times 1 = 5040$$

Ce produit peut être représenté par la notation  $7!$  (qui se lit « factorielle de 7 »).  
Donc,  $7! = 7 \times 6 \times 5 \times 4 \times 3 \times 2 \times 1 = 5040$ .

Cette notation factorielle peut être employée avec n'importe quel nombre entier strictement positif. Par exemple,  $11! = 11 \times 10 \times 9 \times \cdots \times 3 \times 2 \times 1 = 39\,916\,800$ .  
Les trois points «  $\cdots$  » représentent le produit des nombres entiers entre 9 et 3.

De façon générale, pour un nombre entier strictement positif  $n$ ,  $n!$  est égal au produit des nombres entiers strictement positifs de 1 à  $n$ .

Trouve le plus petit nombre entier strictement positif  $n$  tel que  $n!$  se termine par exactement six zéros.

... 000 000



... 000 000

## Problem of the Week

### Problem C and Solution

#### Six Zeros

#### Problem

The product of the first seven positive integers is equal to

$$7 \times 6 \times 5 \times 4 \times 3 \times 2 \times 1 = 5040$$

Mathematicians will write this product as  $7!$ . This is read as “7 factorial”. So,  $7! = 7 \times 6 \times 5 \times 4 \times 3 \times 2 \times 1 = 5040$ .

This factorial notation can be used with any positive integer. For example,  $11! = 11 \times 10 \times 9 \times \cdots \times 3 \times 2 \times 1 = 39\,916\,800$ . The three dots “ $\cdots$ ” represent the product of the integers between 9 and 3.

In general, for a positive integer  $n$ ,  $n!$  is equal to the product of the positive integers from 1 to  $n$ .

Find the smallest positive integer  $n$  such that  $n!$  ends in exactly six zeros.

#### Solution

We start by examining the first few factorials:

$$1! = 1$$

$$2! = 2 \times 1 = 2$$

$$3! = 3 \times 2 \times 1 = 6$$

$$4! = 4 \times 3 \times 2 \times 1 = 24$$

$$5! = 5 \times 4 \times 3 \times 2 \times 1 = \mathbf{120}$$

$$6! = 6 \times (5 \times 4 \times 3 \times 2 \times 1) = 6 \times 5! = 6(120) = 720$$

$$7! = 7 \times (6 \times 5 \times 4 \times 3 \times 2 \times 1) = 7 \times 6! = 7(720) = 5040$$

$$8! = 8 \times (7 \times 6 \times 5 \times 4 \times 3 \times 2 \times 1) = 8 \times 7! = 8(5040) = 40\,320$$

$$9! = 9 \times (8 \times 7 \times 6 \times 5 \times 4 \times 3 \times 2 \times 1) = 9 \times 8! = 9(40\,320) = 362\,880$$

$$10! = 10 \times (9 \times 8 \times 7 \times 6 \times 5 \times 4 \times 3 \times 2 \times 1) = 10 \times 9! = 10(362\,880) = \mathbf{3\,628\,800}$$

These numbers are getting very large and soon will not fit on the display of a standard calculator. So, let's look at what is going on.

We observe that  $5!$  ends in 0 and  $10!$  ends in 00. Notice that the number of zeros at the end of the number increased by one at each of  $5!$  and at  $10!$ . Why is this?



A zero is added to the end of a positive integer when we multiply by 10. Multiplying a number by 10 is the same as multiplying a number by 2 and then by 5, or by 5 and then by 2, since  $2 \times 5 = 10$  and  $5 \times 2 = 10$ . We must determine the next time we multiply by 2 and 5 (in some order), to know the next time the number of zeros at the end of the number increases again. Every time we multiply by an even positive integer we are multiplying by at least one more 2. In the integers from 1 to  $n$ , there are less multiples of 5. So, each multiple of 5 will affect the number of zeros at the end of the product.

Multiplying by 11, 12, 13, and 14 increases the number of 2s we multiply by but not the number of 5s. So the number of zeros at the end of the product does not change. The next time we multiply by a 5 is when we multiply by 15 since  $15 = 5 \times 3$ . So  $15!$  will end in exactly three zeros, 000.

Multiplying by 16, 17, 18, and 19 increases the number of 2s we multiply by but not the number of 5s. So the number of zeros at the end of the product does not change. The next time we multiply by a 5 is when we multiply by 20 since  $20 = 4 \times 5$ . So  $20!$  will end in exactly four zeros, 0000.

Multiplying by 21, 22, 23, and 24 increases the number of 2s we multiply by but not the number of 5s. The next time we multiply by a 5 is when we multiply by 25. In fact, multiplying by 25 is the same as multiplying by 5 twice since  $25 = 5 \times 5$ . So when we multiply by 25, we will increase the number of zeros on the end of the product by two. So  $25!$  will end in exactly six zeros, 000 000.

Therefore, the smallest positive integer  $n$  such that  $n!$  ends in exactly six zeros is 25. (It could be noted that  $26!$ ,  $27!$ ,  $28!$ , and  $29!$  also end in six zeros.)

For the curious,

$$24! = 620\ 448\ 401\ 733\ 239\ 439\ 360\ 000$$

and

$$25! = 15\ 511\ 210\ 043\ 330\ 985\ 984\ 000\ 000$$



## Problème de la semaine

### Problème C

#### Les jetons de Thelma

Thelma a deux piles de jetons de bingo. Dans chaque pile, il y a des jetons verts et des jetons jaunes. Dans une pile, le rapport du nombre de jetons verts au nombre de jetons jaunes est de  $1 : 2$ . Dans la seconde pile, le rapport du nombre de jetons verts au nombre de jetons jaunes est de  $3 : 5$ . Si Thelma a un total de 20 jetons verts, détermine les possibilités pour le nombre total de jetons jaunes.

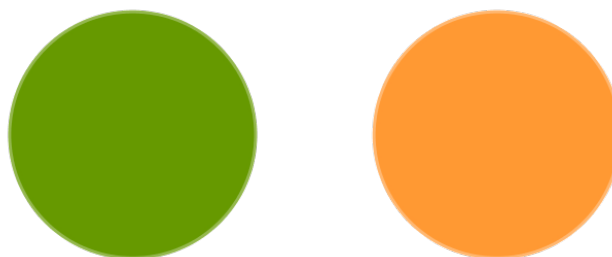



## Problem of the Week

### Problem C and Solution

#### Thelma's Chips

#### Problem

Thelma has two piles of bingo chips. In each pile there are green and yellow chips. In one pile, the ratio of the number of green chips to the number of yellow chips is  $1 : 2$ . In the second pile, the ratio of the number of green chips to the number of yellow chips is  $3 : 5$ . If Thelma has a total of 20 green chips, then determine the possibilities for the total number of yellow chips.

#### Solution

##### Solution 1

In this solution, we first look at all possible combinations of green and yellow chips in the second pile. Since the ratio of the number of green chips to the number of yellow chips in the second pile is  $3 : 5$ , we know that the number of green chips in this second pile must be a positive multiple of 3. We also know that there are at most 20 green chips in this pile. Thus, the only possible values for the number of green chips in the second pile are 3, 6, 9, 12, 15, and 18. Then, using the fact that the ratio of the number of green chips to the number of yellow chips is  $3 : 5$ , we can determine the number of yellow chips in the second pile for each case. We can also determine the number of green chips in the first pile by subtracting the number of green chips in the second pile from 20. Finally, we can determine the number of yellow chips in the first pile by multiplying the number of green chips in the first pile by 2. This information for each case is summarized in the table below.

Number of green chips in pile 2	Number of yellow chips in pile 2	Number of green chips in pile 1	Number of yellow chips in pile 1	Total number of yellow chips
3	5	$20 - 3 = 17$	34	$5 + 35 = 39$
6	10	$20 - 6 = 14$	28	$10 + 28 = 38$
9	15	$20 - 9 = 11$	22	$15 + 22 = 37$
12	20	$20 - 12 = 8$	16	$20 + 16 = 36$
15	25	$20 - 15 = 5$	10	$25 + 10 = 35$
18	30	$20 - 18 = 2$	4	$30 + 4 = 34$

Therefore, there are six possible values for the total number of yellow chips. There could be 34, 35, 36, 37, 38, or 39 yellow chips in total.



## Solution 2

Let  $a$  represent the number of green chips in the first pile, where  $a$  is a positive integer. Since the ratio of green chips to yellow chips in this pile is  $1 : 2$ , then there are  $2a$  yellow chips in this pile.

Let  $3b$  represent the number of green chips in the second pile, where  $b$  is a positive integer. Since the ratio of green chips to yellow chips in this pile is  $3 : 5$ , then there are  $5b$  yellow chips in this pile.

In total, there are 20 green chips, so  $a + 3b = 20$ . Also, the total number of yellow chips is equal to  $2a + 5b$ .

We consider all the possible values for positive integers  $a$  and  $b$  that satisfy the equation  $a + 3b = 20$ . Using these values of  $a$  and  $b$ , we can then find the possible values of  $2a + 5b$ , and hence the possible values for the total number of yellow chips.

The results are summarized in the table below.

$a + 3b$	$b$	$a$	$2a + 5b$
20	1	17	39
20	2	14	38
20	3	11	37
20	4	8	36
20	5	5	35
20	6	2	34

Therefore, there are six possible values for the total number of yellow chips. There could be 34, 35, 36, 37, 38, or 39 yellow chips in total.



## Problème de la semaine

### Problème C

#### Parties égales

En effectuant deux coupes, on veut diviser la grille de  $6\text{ m} \times 6\text{ m}$  dans la figure ci-dessous en trois parties de même aire.

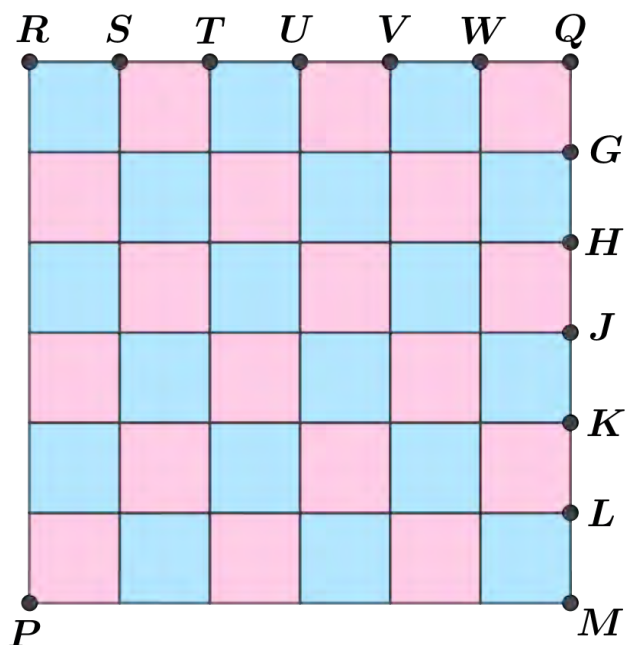

Une façon de procéder consiste à effectuer une coupe horizontale passant par  $H$  et une seconde coupe horizontale passant par  $K$ . Quoique cette méthode donne le résultat souhaité, elle n'est pas très créative.

Pour rendre les choses un peu plus intéressantes, supposons que chacune des deux coupes doive commencer au point  $P$  et doit passer par un point situé sur les bords de la grille.

Trouve la longueur de chaque coupe. Arrondis votre réponse au dixième près.

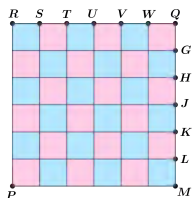

## Problem of the Week

### Problem C and Solution

### All Equal

#### Problem

Using two cuts, we want to divide the 6 m by 6 m grid shown into three regions of equal area.

One way to do so is by making a horizontal cut through  $H$  and a second horizontal cut through  $K$ . This method of cutting the grid works, but is not very creative.

To make things a little more interesting, we must still make two straight cuts, but each cut must start at point  $P$ . Each of these two cuts will pass through a point on the outer perimeter of the grid.

Find the length of each cut. Round your answer to one decimal.

#### Solution

The area of the entire 6 m by 6 m square grid is  $6 \times 6 = 36 \text{ m}^2$ . Since the square is divided into three regions of equal area, the area of each region must be  $\frac{36}{3} = 12 \text{ m}^2$ .

Consider the line through  $P$  that passes through some point on side  $QM$ . Let  $A$  be the point where this line intersects  $QM$ .

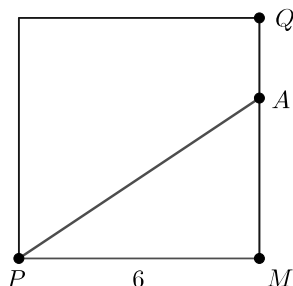

Since  $\angle PMQ = 90^\circ$ ,  $\triangle PMA$  is a right-angled triangle with base  $PM = 6 \text{ m}$  and height  $MA$ .

Using the formula  $\text{area} = \frac{\text{base} \times \text{height}}{2}$ , we have  $\text{area of } \triangle PMA = \frac{6 \times MA}{2} = 3 \times MA$ .

We need the area of  $\triangle PMA$  to be  $12 \text{ m}^2$ . Therefore,  $3 \times MA = 12$ , and so  $MA = 4 \text{ m}$ . Since  $H$  is the point on  $QM$  with  $MH = 4 \text{ m}$ , we must have  $A = H$ . Therefore, one line passes through the point  $H$ .

Since  $\triangle PMA$  is a right-angled triangle, using the Pythagorean Theorem we have

$$\begin{aligned} PA^2 &= PM^2 + MA^2 \\ &= 6^2 + 4^2 \\ &= 36 + 16 \\ &= 52 \end{aligned}$$

Therefore,  $PA = \sqrt{52} \approx 7.2$ , since  $PA > 0$ .





Consider the line through  $P$  that passes through some point on side  $RQ$ . Let  $B$  be the point where this line intersects  $RQ$ .

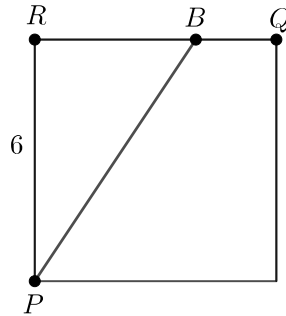

Since  $\angle PRQ = 90^\circ$ ,  $\triangle PRB$  is a right-angled triangle with height  $PR = 6$  m and base  $RB$ .

Using the formula  $\text{area} = \frac{\text{base} \times \text{height}}{2}$ , we have area of  $\triangle PRB = \frac{RB \times 6}{2} = 3 \times RB$ .

We need the area of  $\triangle PRB$  to be  $12 \text{ m}^2$ . Therefore,  $3 \times RB = 12$ , and so  $RB = 4$  m. Since  $V$  is the point on  $RQ$  with  $RV = 4$  m, we must have  $B = V$ . Therefore, the other line passes through the point  $V$ .

Therefore, one line passes through point  $H$  and the other passes through point  $V$ .

Since  $\triangle PRB$  is a right-angled triangle, using the Pythagorean Theorem we have

$$\begin{aligned} PB^2 &= PR^2 + RB^2 \\ &= 6^2 + 4^2 \\ &= 36 + 16 \\ &= 52 \end{aligned}$$

Therefore,  $PB = \sqrt{52} \approx 7.2$ , since  $PB > 0$ .

Therefore, the length of each cut is approximately 7.2 m.

#### EXTENSION:

Try dividing the grid into three regions of equal area using three cuts. (Each cut does not necessarily need to be to the outer perimeter of the grid.)



## Problème de la semaine

### Problème C

#### Entrée-sortie

La machine d'entrée-sortie PDLs prend un nombre en entrée et y ajoute 10. Ensuite, la machine prend cette somme et la multiplie par 2. Enfin, la machine prend ce produit et en soustrait 30. Cette différence est le résultat final que la machine produit comme sortie.

Anala et Mei présentent chacune un nombre entier strictement positif comme entrée. Si les deux sorties produites ont une somme de 130, combien y a-t-il de possibilités pour le nombre entier strictement positif qu'Anala a présenté comme entrée ?

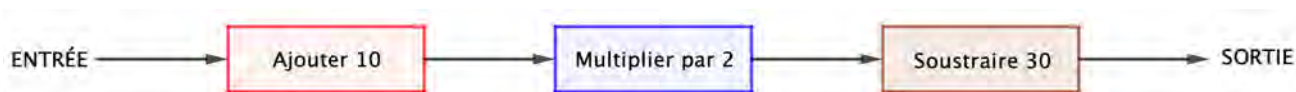



## Problem of the Week

### Problem C and Solution

#### Two Numbers In

##### Problem

The POTW Input/Output Machine takes a number as input and adds 10 to the number. The machine then takes this sum and multiplies it by 2. Finally, the machine takes this product, subtracts 30 from the number, and outputs this new number.

Anala and Mei each input a positive integer into the machine. If the sum of their two outputs is 130, how many possibilities are there for the positive integer that Anala input into the machine?

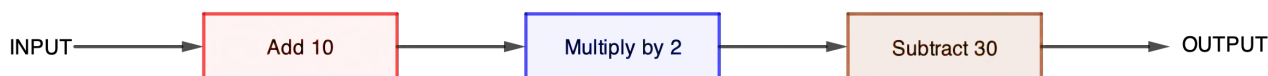

##### Solution

We will work backward from the final sum, 130, by ‘undoing’ each of the three operations to determine the sum of their two numbers before any operations were performed.

The final operation performed by the machine on each number was to subtract 30. Subtracting 30 from each number decreases their sum by 60. Therefore, the sum of the two numbers immediately before the third operation was performed was  $130 + 60 = 190$ .

Multiplying each of their numbers by 2 increases the sum of the two numbers by a factor of 2. Since the second sum of their two numbers was 190, the sum of their two numbers immediately before the second operation was performed must have been  $190 \div 2 = 95$ .

Finally, the first operation performed by each of Anala and Mei was to add 10 to their number. Adding 10 to each of their numbers increases the sum by 20, and so the sum of their numbers before the first operation must have been  $95 - 20 = 75$ .

Each of their original integers are positive and the two integers have a sum of 75.

Therefore, Anala’s original integer could be any integer from 1 to 74, inclusive. Thus, there are 74 possibilities for Anala’s original integer.

---

# Géométrie et mesure (G)

---





## Problème de la semaine

### Problème C

#### Deux carrés

Simone a une corde qui mesure 60 cm de long. Elle coupe la corde en deux parties de manière que les longueurs des deux bouts de cordes résultantes soient dans un rapport de 7 : 3. Chaque bout de corde est disposé de manière à former un carré (les deux extrémités de la corde étant donc reliées).

Quelle est l'aire totale des deux carrés?





## Problem of the Week

### Problem C and Solution

### Two Squares

#### Problem

Simone has a rope that is 60 cm long. They cut the rope into two pieces so that the ratio of the lengths of the two pieces is 7 : 3. Each piece of the rope is then arranged, with its two ends touching, to form a square.

What is the total area of the two squares?

#### Solution

Since the rope is cut in the ratio of 7 : 3, the ratio of the longer piece to the whole rope will be 7 : (7 + 3) or 7 : 10. This means the length of the longer piece will be  $\frac{7}{10}$  of the length of the whole rope. Similarly, the length of the shorter piece would be  $\frac{3}{10}$  of the length of the whole rope. Therefore, the longer piece is  $\frac{7}{10}$  of 60 or  $\frac{7}{10} \times 60 = 42$  cm long. Also, the shorter piece is  $\frac{3}{10}$  of 60 or  $\frac{3}{10} \times 60 = 18$  cm long.

Each of the two pieces is then used to form a square. The perimeter of each square is the length of the rope used to form it. The side length of the longer square is  $42 \div 4 = 10.5$  cm and the side length of the shorter square is  $18 \div 4 = 4.5$  cm.

To find the area of each square, we multiply the length by the width. In effect, to find the area of the square, we square the side length. Thus, the area of the larger square is  $10.5 \times 10.5 = 10.5^2 = 110.25$  cm<sup>2</sup> and the area of the smaller square is  $4.5 \times 4.5 = 4.5^2 = 20.25$  cm<sup>2</sup>.

Therefore, the total area of the two squares is  $110.25 + 20.25 = 130.5$  cm<sup>2</sup>.

#### FOR FURTHER THOUGHT:

The ratio of the area of the larger square to the area of the smaller square is

$$110.25 : 20.25 = 11025 : 2025 = 441 : 81 = 49 : 9 = 7^2 : 3^2$$

Notice that the ratio of the perimeter of the larger square to the perimeter of the smaller square is 7 : 3 and the ratio of their areas is  $7^2 : 3^2$ . In general, if the ratio of the perimeters of two squares is  $a : b$ , is it true that the ratio of the areas of the two squares is  $a^2 : b^2$ ?



## Problème de la semaine

### Problème C

#### Trois périmètres

Une *médiane* d'un triangle est un segment de droite joignant un sommet du triangle au milieu du côté opposé.

Dans le triangle  $DEF$ , on trace une médiane du sommet  $D$  au milieu  $M$  de  $EF$ .

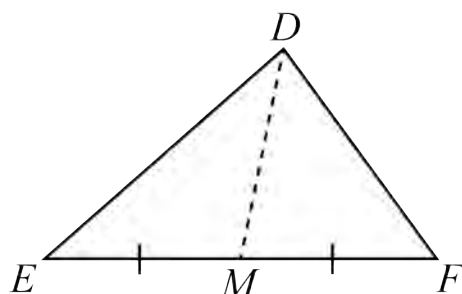

Le triangle  $DEF$  a un périmètre de 24. Le triangle  $DEM$  a un périmètre de 18. Le triangle  $DFM$  a un périmètre de 16. Détermine la longueur de la médiane  $DM$ .

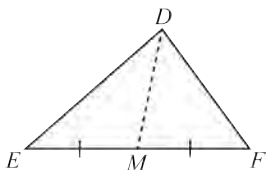

## Problem of the Week

### Problem C and Solution

#### Three Perimeters

#### Problem

A *median* is a line segment drawn from the vertex of a triangle to the midpoint of the opposite side.

In  $\triangle DEF$ , a median is drawn from vertex  $D$ , meeting side  $EF$  at point  $M$ . The perimeter of  $\triangle DEF$  is 24. The perimeter of  $\triangle DEM$  is 18. The perimeter  $\triangle DFM$  is 16. Determine the length of the median  $DM$ .

#### Solution

##### Solution 1

The perimeter of a triangle is equal to the sum of its three side lengths. Notice that the length of side  $EF$  is equal to the sum of the lengths of sides  $EM$  and  $MF$ . It follows that when we combine the perimeters of  $\triangle DEM$  and  $\triangle DFM$ , we obtain the perimeter of  $\triangle DEF$  plus two lengths of the median  $DM$ .

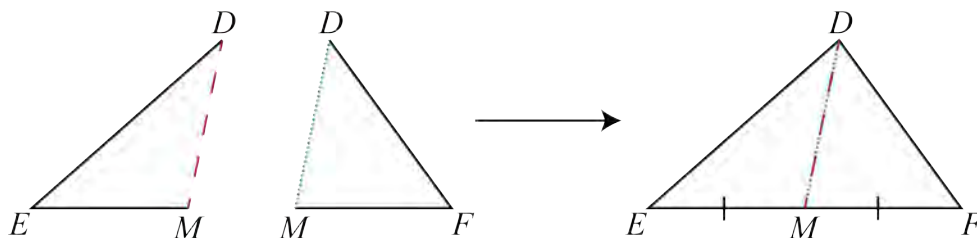

In other words, since the perimeter of  $\triangle DEM$  is 18, the perimeter of  $\triangle DFM$  is 16, and the perimeter of  $\triangle DEF$  is 24, it follows that  $18 + 16 = 24 + 2 \times DM$ . Then  $34 = 24 + 2 \times DM$ , and so  $2 \times DM = 10$ . Therefore, the length of the median  $DM$  is 5.

##### Solution 2

In this solution, we take a more algebraic approach to solving the problem, using more formal equation solving.

Let  $DE = t$ ,  $EM = p$ ,  $MF = q$ ,  $DF = r$ , and  $DM = m$ .

Since the perimeter of  $\triangle DEM$  is 18, we can write the following equation.

$$\begin{aligned}t + p + m &= 18 \\t + p &= 18 - m\end{aligned}\tag{1}$$





Since the perimeter of  $\triangle DFM$  is 16, we can write the following equation.

$$\begin{aligned}q + r + m &= 16 \\q + r &= 16 - m\end{aligned}\tag{2}$$

Since the perimeter of  $\triangle DEF$  is 24, we can write the following equation.

$$t + p + q + r = 24\tag{3}$$

Adding equations (1) and (2) gives the following.

$$t + p = 18 - m\tag{1}$$

$$q + r = 16 - m\tag{2}$$

$$t + p + q + r = 18 - m + 16 - m$$

However from equation (3), we know that  $t + p + q + r = 24$ . So we can write and solve the following equation.

$$18 - m + 16 - m = 24$$

$$34 - 2m = 24$$

$$-2m = 24 - 34$$

$$-2m = -10$$

$$\frac{-2m}{-2} = \frac{-10}{-2}$$

$$m = 5$$

Therefore, the length of the median  $DM$  is 5.

### EXTENSION:

In the solution we never used the fact that  $DM$  is a median and that  $EM = MF$ . This means that there could be other triangles that satisfy the conditions of the problem without  $DM$  being the median. Indeed there are! Try creating a few different triangles with  $DM = 5$  that satisfy all the conditions of the problem except the condition that  $DM$  is a median. You can do this using manipulatives, geometry software, or by hand. However, you may need some high school mathematics to calculate the precise dimensions.

It turns out that there is only one triangle that satisfies all the conditions of the problem including the fact that  $DM$  is a median.



## Problème de la semaine

### Problème C

#### Les pièces manquantes

Voici quelques caractéristiques du triangle  $PQR$ :

- Le point  $S$  est situé sur le côté  $PR$  et le point  $T$  est situé sur le côté  $PQ$ .
- La distance entre  $P$  et  $S$  est égale à la distance entre  $T$  et  $Q$ .
- La distance entre  $S$  et  $R$  est égale à la distance entre  $P$  et  $T$ .
- $\angle PRQ = 40^\circ$  et  $\angle PTS = 20^\circ$ .

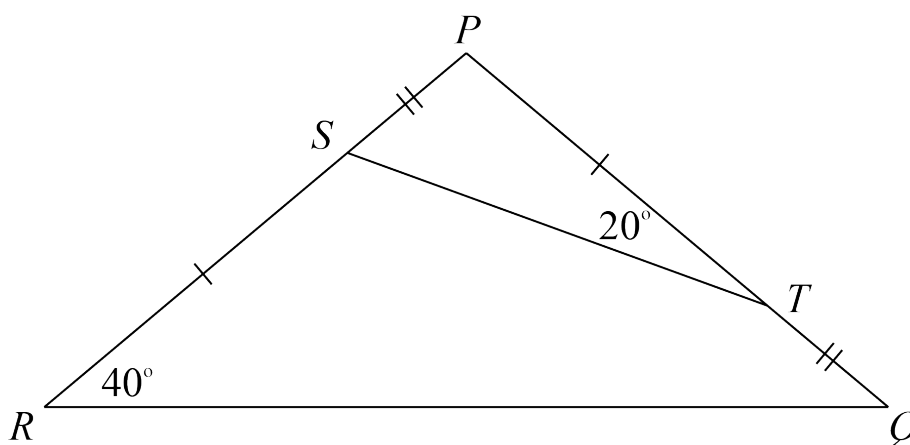

Détermine les mesures des cinq autres angles intérieurs, soit les angles  $RPQ$ ,  $STQ$ ,  $TQR$ ,  $RST$  et  $PST$ .

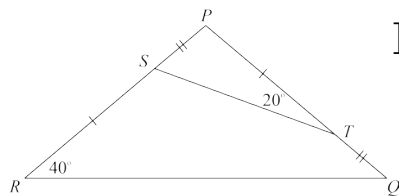

## Problem of the Week

### Problem C and Solution

#### The Missing Pieces

#### Problem

The following information is known about  $\triangle PQR$ .

- The point  $S$  is on side  $PR$  and the point  $T$  is on side  $PQ$ .
- The distance from  $P$  to  $S$  is equal to the distance from  $T$  to  $Q$ .
- The distance from  $S$  to  $R$  is equal to the distance from  $P$  to  $T$ .
- $\angle PRQ = 40^\circ$  and  $\angle PTS = 20^\circ$ .

Determine the value of each of the five other interior angles. That is, determine the values of  $\angle RPQ$ ,  $\angle STQ$ ,  $\angle TQR$ ,  $\angle RST$ , and  $\angle PST$ .

#### Solution

First, we let  $\angle RPQ$  measure  $a^\circ$ ,  $\angle STQ$  measure  $b^\circ$ ,  $\angle TQR$  measure  $c^\circ$ ,  $\angle RST$  measure  $d^\circ$ , and  $\angle PST$  measure  $e^\circ$ .

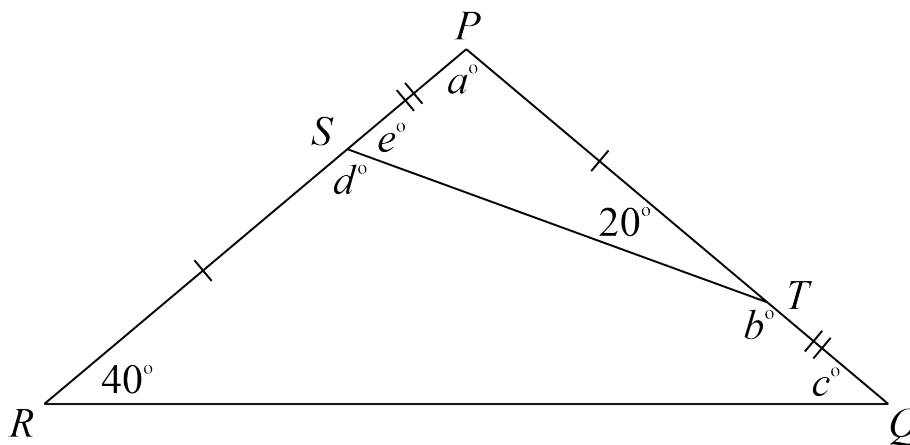

Since  $\angle PTQ$  is a straight angle,  $20 + b = 180$ , and so  $b = 160$ .

Since  $PS = TQ$  and  $SR = PT$ , it follows that  $PS + PR = PT + TQ$ , and so  $PR = PQ$  and  $\triangle PQR$  is isosceles. Therefore  $\angle RPQ = \angle PQR$ , and so  $c = 40$ .

Since the angles in a triangle sum to  $180^\circ$ , in  $\triangle PQR$ ,

$$a + 40 + c = 180$$

$$a + 40 + 40 = 180$$

$$a + 80 = 180$$

$$a = 100$$



Similarly, in  $\triangle PST$ ,

$$a + e + 20 = 180$$

$$100 + e + 20 = 180$$

$$120 + e = 180$$

$$e = 60$$

Since  $\angle PSR$  is a straight angle,

$$e + d = 180$$

$$60 + d = 180$$

$$d = 120$$

We have determined the value of all the other five interior angles.

$\angle RPQ = a^\circ = 100^\circ$ ,  $\angle STQ = b^\circ = 160^\circ$ ,  $\angle TQR = c^\circ = 40^\circ$ ,

$\angle RST = d^\circ = 120^\circ$ , and  $\angle PST = e^\circ = 60^\circ$ .

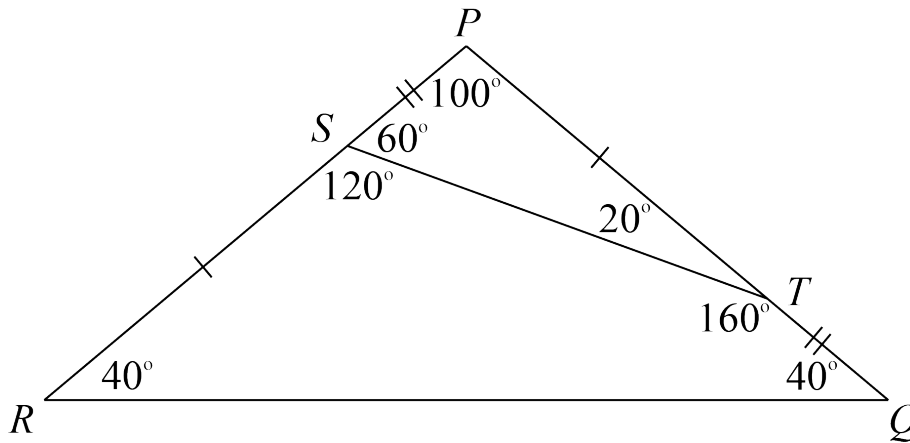



## Problème de la semaine

### Problème C

#### Drôle de glacière

Une boîte métallique en forme de prisme droit à base rectangulaire a une base dont les dimensions sont de  $18\text{ cm} \times 22\text{ cm}$  et une hauteur de  $77\text{ cm}$ . La boîte doit être remplie d'eau, qui sera ensuite congelée. Lorsque l'eau gèle, elle se dilate d'environ  $10\%$ . Détermine la profondeur maximale à laquelle on peut remplir la boîte d'eau pour que la glace ne dépasse pas le haut du récipient lorsque l'eau gèle.

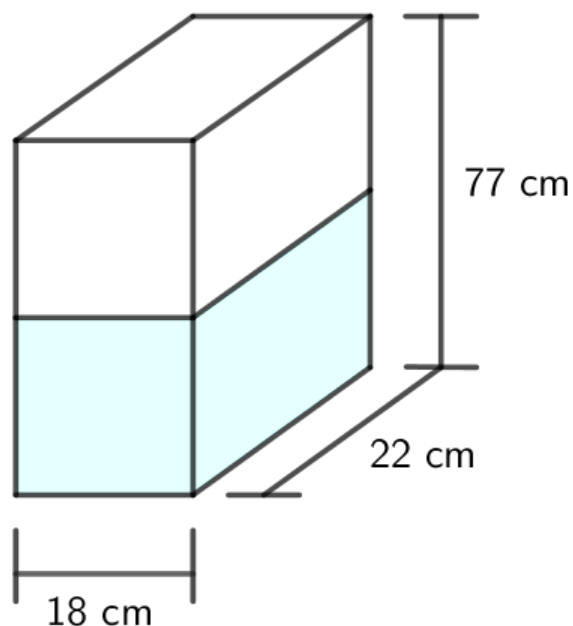

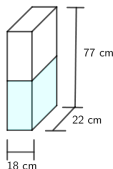

## Problem of the Week

### Problem C and Solution

#### Ice Box

#### Problem

A metal box in the form of a rectangular prism has an 18 cm by 22 cm base and a height of 77 cm. The box is to be filled with water, which will then be frozen. When water freezes it expands by approximately 10%. Determine the maximum depth to which the box can be filled with water so that when the water freezes, the ice does not go above the top of the container.

#### Solution

##### Solution 1

To determine the volume of a rectangular prism, we multiply its length, width, and height together. So, the maximum volume of the metal box is

$$18 \times 22 \times 77 = 30\,492 \text{ cm}^3$$

Let the original depth of water in the metal box be  $h$  cm.

The water volume before freezing is  $18 \times 22 \times h = (396 \times h) \text{ cm}^3$ . After the water freezes, the volume increases by 10% to 110% of its current volume. That is, after freezing the volume is

$$110\% \text{ of } 396 \times h = 1.1 \times 396 \times h = (435.6 \times h) \text{ cm}^3$$

But the volume after freezing is the maximum volume,  $30\,492 \text{ cm}^3$ . Therefore,  $435.6 \times h = 30\,492$  and it follows that  $h = 30\,492 \div 435.6 = 70$  cm.

Therefore, the maximum depth to which the box can be filled is 70 cm.

##### Solution 2

In this solution we note that the length and width remain the same in the volume calculations before and after the water freezes. We need only concern ourselves with the change in the depth of the water.

Let the original depth of water in the container be  $h$  cm.

After freezing, the depth increases by 10% to 110% of its depth before freezing. So, after freezing the depth will be 110% of  $h = 1.1 \times h = 77$  cm, the maximum height of the container. Then  $h = 77 \div 1.1 = 70$  cm.

Therefore, the maximum depth to which the box can be filled is 70 cm.



## Problème de la semaine

### Problème C

#### Maison de poupée

Le premier étage d'une maison de poupée a la forme d'un rectangle. Son plan est illustré dans la figure suivante.

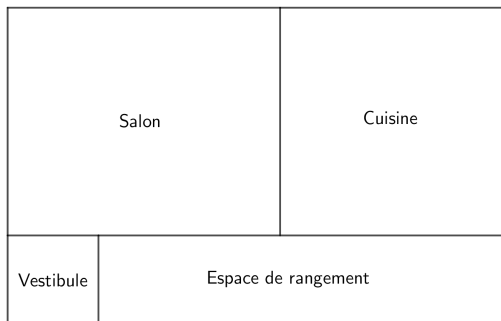

Le vestibule et la cuisine sont tous deux carrés et ont respectivement des aires de  $400 \text{ cm}^2$  et  $2500 \text{ cm}^2$ . Le salon est rectangulaire et a une aire de  $3000 \text{ cm}^2$ .

Détermine l'aire de l'espace de rangement rectangulaire.



# Problem of the Week

## Problem C and Solution

### Dollhouse

#### Problem

The first level of a dollhouse is in the shape of a rectangle. Its floor plan is shown in the following diagram.

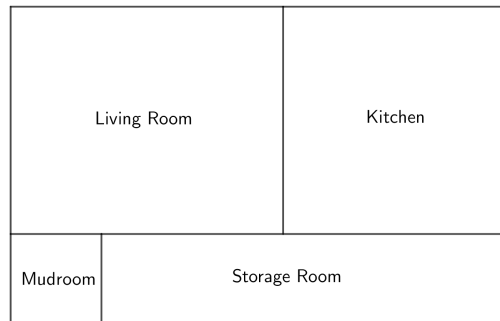

Both the mudroom and the kitchen are square with areas of  $400 \text{ cm}^2$  and  $2500 \text{ cm}^2$ , respectively. The living room is rectangular with an area of  $3000 \text{ cm}^2$ .

Determine the area of the rectangular storage room.

#### Solution

Let the width of a room be the vertical length of the room on the diagram. Let the length of a room be the horizontal length of the room on the diagram.

The kitchen is a square and has an area of  $2500 \text{ cm}^2$ . Its length and width must both be  $50 \text{ cm}$  since  $50 \times 50 = 2500 \text{ cm}^2$ . The living room and kitchen have the same width. So the width of the living room must also be  $50 \text{ cm}$ . But the area of the living room is  $3000 \text{ cm}^2$ , so the length of the living room is  $60 \text{ cm}$  since  $50 \times 60 = 3000 \text{ cm}^2$ .

The mudroom is a square and has an area of  $400 \text{ cm}^2$ . Its length and width must both be  $20 \text{ cm}$  since  $20 \times 20 = 400 \text{ cm}^2$ . The mudroom and storage room have the same width. So the width of the storage room must also be  $20 \text{ cm}$ .

Now the length of the whole house can be calculated in two ways. We will equate these two expressions to find the length of the storage room.

$$\begin{aligned}\text{mudroom length} + \text{storage room length} &= \text{living room length} + \text{kitchen length} \\ 20 + \text{storage room length} &= 60 + 50 \\ 20 + \text{storage room length} &= 110 \\ \text{storage room length} &= 90 \text{ cm}\end{aligned}$$

Since the width of the storage room is  $20 \text{ cm}$  and the length of the storage room is  $90 \text{ cm}$ , the area of the storage room is  $20 \times 90 = 1800 \text{ cm}^2$ .





## Problème de la semaine

### Problème C

#### Un triangle plus grand

Naveen a dessiné un triangle rectangle, soit le triangle  $ABC$ , dont l'aire est de  $14 \text{ cm}^2$ . Son frère Anand a dessiné un triangle rectangle plus grand, soit le triangle  $DEF$ , dont les côtés sont quatre fois plus longs que les côtés correspondants du triangle  $ABC$ . Plus spécifiquement,  $DE = 4 \times AB$ ,  $EF = 4 \times BC$  et  $DF = 4 \times AC$ .

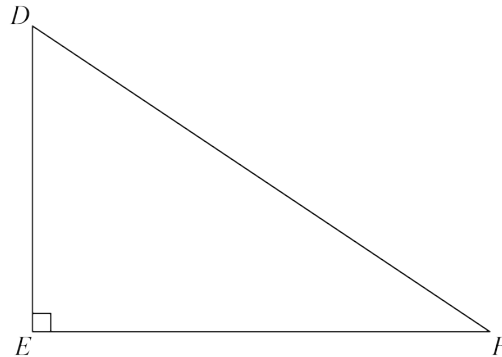
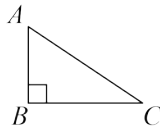

Calcule l'aire du triangle  $DEF$ .



## Problem of the Week

### Problem C and Solution

### A Bigger Triangle

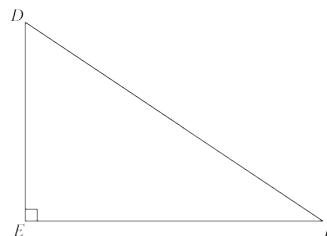
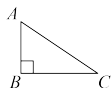

#### Problem

Naveen drew a right-angled triangle,  $\triangle ABC$ , with an area of  $14 \text{ cm}^2$ . His brother Anand drew a bigger right-angled triangle,  $\triangle DEF$ , with side lengths four times the lengths of the sides in  $\triangle ABC$ . In particular,  $DE = 4 \times AB$ ,  $EF = 4 \times BC$ , and  $DF = 4 \times AC$ . Calculate the area of  $\triangle DEF$ .

#### Solution

In  $\triangle ABC$ , let  $b$  represent the length of the base,  $BC$ , and  $h$  represent the length of the height,  $AB$ . Then the area of  $\triangle ABC$  is equal to  $\frac{b \times h}{2}$ . We know this area is equal to  $14 \text{ cm}^2$ , so it follows that  $14 = \frac{b \times h}{2}$ , or  $28 = b \times h$ .

$\triangle DEF$  is formed by multiplying each of the side lengths of  $\triangle ABC$  by 4. So the length of the base of  $\triangle DEF$  is equal to  $4 \times b$  and the length of the height is equal to  $4 \times h$ . We can calculate the area of  $\triangle DEF$  as follows.

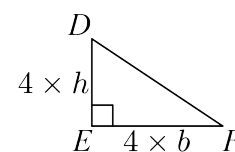
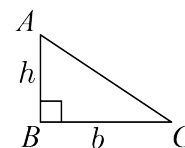

$$\begin{aligned} \text{area of } \triangle DEF &= \frac{(4 \times b) \times (4 \times h)}{2} \\ &= \frac{16 \times b \times h}{2} \\ &= \frac{16 \times 28}{2}, \text{ since } b \times h = 28 \\ &= 224 \end{aligned}$$

Therefore, the area of  $\triangle DEF$  is  $224 \text{ cm}^2$ .

#### EXTENSION:

Notice that  $\triangle DEF$  has side lengths that are each 4 times the corresponding side lengths of  $\triangle ABC$  and that the area of  $\triangle DEF$  ended up being  $224 = 16 \times 14 = 4^2 \times \text{area of } \triangle ABC$ .

Show that if  $\triangle DEF$  has side lengths that are each  $k$  times the corresponding side lengths of  $\triangle ABC$ , then the area of  $\triangle DEF$  will be equal to  $k^2$  times the area of  $\triangle ABC$ .



## Problème de la semaine

### Problème C

#### Un entre-deux

Dans le carré  $OABC$ , les points  $A$  et  $C$  sont situés sur la circonférence du cercle dont le centre est le point  $O$  tandis que le point  $B$  est situé à l'extérieur du cercle. Le carré  $OABC$  a une aire de  $36 \text{ m}^2$ .

Détermine au centième près, l'aire de la région ombrée. Remarque que cette région est située à l'intérieur du carré  $OABC$  et à l'extérieur du cercle dont le centre est le point  $O$ .

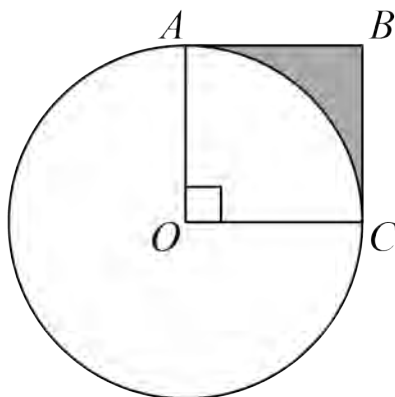

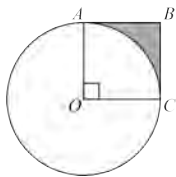

## Problem of the Week

### Problem C and Solution

#### Just Outside

#### Problem

In square  $OABC$ , points  $A$  and  $C$  lie on the circumference of a circle with centre  $O$ , and  $B$  lies outside of the circle. Square  $OABC$  has an area of  $36 \text{ m}^2$ .

Determine the area of the shaded region inside square  $OABC$  and outside the circle with centre  $O$ , rounded to two decimal places.

#### Solution

Since  $OABC$  is a square with an area of  $36 \text{ m}^2$ , its side length must be  $6 \text{ m}$ . That is,  $OA = OC = 6 \text{ m}$ .

Since  $A$  lies on the circumference of the circle with centre  $O$ , the radius of the circle is  $r = OA = 6 \text{ m}$ .

Therefore, the area of the circle is  $\pi \times r^2 = \pi \times 6^2 = 36\pi \text{ m}^2$ .

Since  $OABC$  is a square,  $\angle AOC = 90^\circ$ .

Therefore, the area of sector  $OAC$  is  $\frac{90^\circ}{360^\circ} = \frac{1}{4}$  of the area of the circle.

In other words, the area of the sector  $OAC$  is  $\frac{1}{4} \times 36\pi = 9\pi \text{ m}^2$ .

Therefore,

$$\begin{aligned}\text{Area of shaded region} &= \text{Area of square } OABC - \text{Area of sector } OAC \\ &= 36 - 9\pi \\ &\approx 7.73 \text{ m}^2\end{aligned}$$

**NOTE:** In the problem you were asked to give your answer rounded to two decimal places. However, many times in mathematics we are actually interested in the *exact* answer. In this case, the exact answer would be  $(36 - 9\pi) \text{ m}^2$ .



## Problème de la semaine

### Problème C

#### Parties égales

En effectuant deux coupes, on veut diviser la grille de  $6\text{ m} \times 6\text{ m}$  dans la figure ci-dessous en trois parties de même aire.

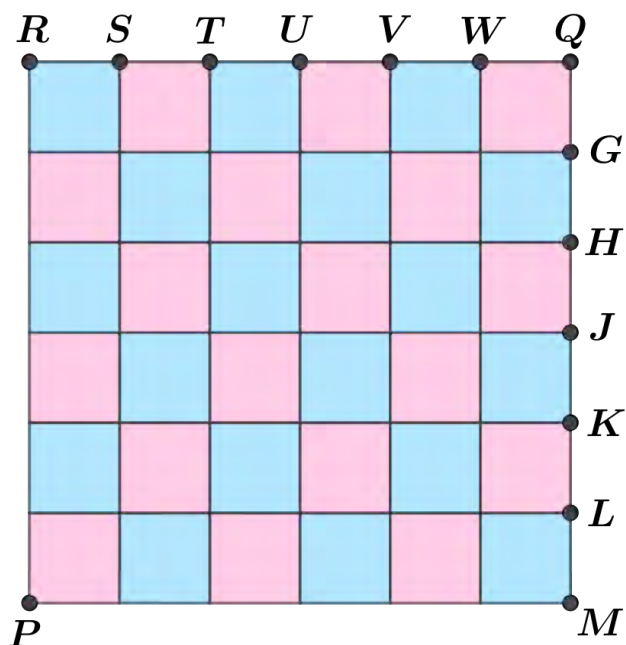

Une façon de procéder consiste à effectuer une coupe horizontale passant par  $H$  et une seconde coupe horizontale passant par  $K$ . Quoique cette méthode donne le résultat souhaité, elle n'est pas très créative.

Pour rendre les choses un peu plus intéressantes, supposons que chacune des deux coupes doive commencer au point  $P$  et doit passer par un point situé sur les bords de la grille.

Trouve la longueur de chaque coupe. Arrondis votre réponse au dixième près.

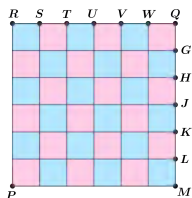

## Problem of the Week

### Problem C and Solution

### All Equal

#### Problem

Using two cuts, we want to divide the 6 m by 6 m grid shown into three regions of equal area.

One way to do so is by making a horizontal cut through  $H$  and a second horizontal cut through  $K$ . This method of cutting the grid works, but is not very creative.

To make things a little more interesting, we must still make two straight cuts, but each cut must start at point  $P$ . Each of these two cuts will pass through a point on the outer perimeter of the grid.

Find the length of each cut. Round your answer to one decimal.

#### Solution

The area of the entire 6 m by 6 m square grid is  $6 \times 6 = 36 \text{ m}^2$ . Since the square is divided into three regions of equal area, the area of each region must be  $\frac{36}{3} = 12 \text{ m}^2$ .

Consider the line through  $P$  that passes through some point on side  $QM$ . Let  $A$  be the point where this line intersects  $QM$ .

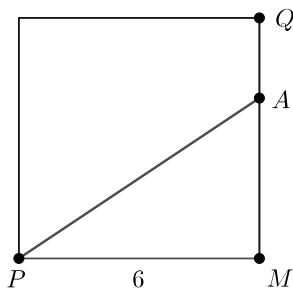

Since  $\angle PMQ = 90^\circ$ ,  $\triangle PMA$  is a right-angled triangle with base  $PM = 6 \text{ m}$  and height  $MA$ .

Using the formula  $\text{area} = \frac{\text{base} \times \text{height}}{2}$ , we have  $\text{area of } \triangle PMA = \frac{6 \times MA}{2} = 3 \times MA$ .

We need the area of  $\triangle PMA$  to be  $12 \text{ m}^2$ . Therefore,  $3 \times MA = 12$ , and so  $MA = 4 \text{ m}$ . Since  $H$  is the point on  $QM$  with  $MH = 4 \text{ m}$ , we must have  $A = H$ . Therefore, one line passes through the point  $H$ .

Since  $\triangle PMA$  is a right-angled triangle, using the Pythagorean Theorem we have

$$\begin{aligned} PA^2 &= PM^2 + MA^2 \\ &= 6^2 + 4^2 \\ &= 36 + 16 \\ &= 52 \end{aligned}$$

Therefore,  $PA = \sqrt{52} \approx 7.2$ , since  $PA > 0$ .



Consider the line through  $P$  that passes through some point on side  $RQ$ . Let  $B$  be the point where this line intersects  $RQ$ .

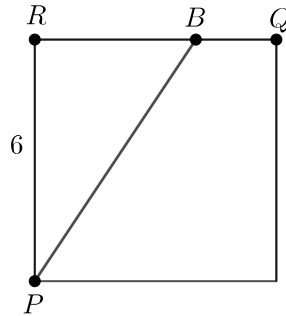

Since  $\angle PRQ = 90^\circ$ ,  $\triangle PRB$  is a right-angled triangle with height  $PR = 6$  m and base  $RB$ .

Using the formula  $\text{area} = \frac{\text{base} \times \text{height}}{2}$ , we have area of  $\triangle PRB = \frac{RB \times 6}{2} = 3 \times RB$ .

We need the area of  $\triangle PRB$  to be  $12 \text{ m}^2$ . Therefore,  $3 \times RB = 12$ , and so  $RB = 4$  m. Since  $V$  is the point on  $RQ$  with  $RV = 4$  m, we must have  $B = V$ . Therefore, the other line passes through the point  $V$ .

Therefore, one line passes through point  $H$  and the other passes through point  $V$ .

Since  $\triangle PRB$  is a right-angled triangle, using the Pythagorean Theorem we have

$$\begin{aligned} PB^2 &= PR^2 + RB^2 \\ &= 6^2 + 4^2 \\ &= 36 + 16 \\ &= 52 \end{aligned}$$

Therefore,  $PB = \sqrt{52} \approx 7.2$ , since  $PB > 0$ .

Therefore, the length of each cut is approximately 7.2 m.

#### EXTENSION:

Try dividing the grid into three regions of equal area using three cuts. (Each cut does not necessarily need to be to the outer perimeter of the grid.)

---

# Algèbre (A)

---







## Problème de la semaine

### Problème C

#### Trois périmètres

Une *médiane* d'un triangle est un segment de droite joignant un sommet du triangle au milieu du côté opposé.

Dans le triangle  $DEF$ , on trace une médiane du sommet  $D$  au milieu  $M$  de  $EF$ .

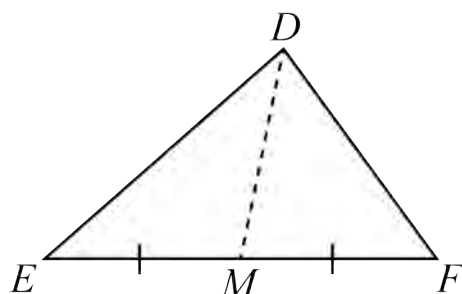

Le triangle  $DEF$  a un périmètre de 24. Le triangle  $DEM$  a un périmètre de 18. Le triangle  $DFM$  a un périmètre de 16. Détermine la longueur de la médiane  $DM$ .

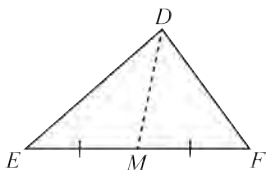

## Problem of the Week

### Problem C and Solution

#### Three Perimeters

#### Problem

A *median* is a line segment drawn from the vertex of a triangle to the midpoint of the opposite side.

In  $\triangle DEF$ , a median is drawn from vertex  $D$ , meeting side  $EF$  at point  $M$ . The perimeter of  $\triangle DEF$  is 24. The perimeter of  $\triangle DEM$  is 18. The perimeter  $\triangle DFM$  is 16. Determine the length of the median  $DM$ .

#### Solution

##### Solution 1

The perimeter of a triangle is equal to the sum of its three side lengths. Notice that the length of side  $EF$  is equal to the sum of the lengths of sides  $EM$  and  $MF$ . It follows that when we combine the perimeters of  $\triangle DEM$  and  $\triangle DFM$ , we obtain the perimeter of  $\triangle DEF$  plus two lengths of the median  $DM$ .

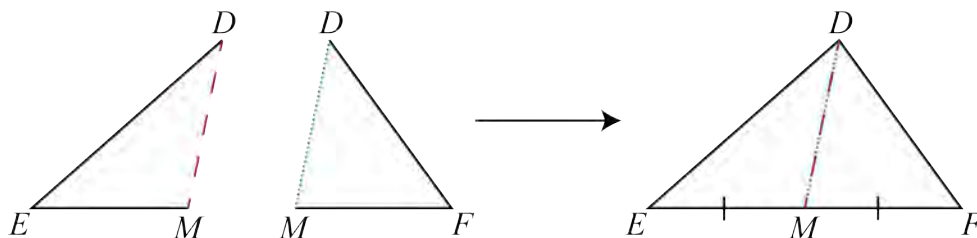

In other words, since the perimeter of  $\triangle DEM$  is 18, the perimeter of  $\triangle DFM$  is 16, and the perimeter of  $\triangle DEF$  is 24, it follows that  $18 + 16 = 24 + 2 \times DM$ . Then  $34 = 24 + 2 \times DM$ , and so  $2 \times DM = 10$ . Therefore, the length of the median  $DM$  is 5.

##### Solution 2

In this solution, we take a more algebraic approach to solving the problem, using more formal equation solving.

Let  $DE = t$ ,  $EM = p$ ,  $MF = q$ ,  $DF = r$ , and  $DM = m$ .

Since the perimeter of  $\triangle DEM$  is 18, we can write the following equation.

$$\begin{aligned}t + p + m &= 18 \\t + p &= 18 - m\end{aligned}\tag{1}$$



Since the perimeter of  $\triangle DFM$  is 16, we can write the following equation.

$$\begin{aligned}q + r + m &= 16 \\q + r &= 16 - m\end{aligned}\tag{2}$$

Since the perimeter of  $\triangle DEF$  is 24, we can write the following equation.

$$t + p + q + r = 24\tag{3}$$

Adding equations (1) and (2) gives the following.

$$t + p = 18 - m\tag{1}$$

$$q + r = 16 - m\tag{2}$$

$$t + p + q + r = 18 - m + 16 - m$$

However from equation (3), we know that  $t + p + q + r = 24$ . So we can write and solve the following equation.

$$18 - m + 16 - m = 24$$

$$34 - 2m = 24$$

$$-2m = 24 - 34$$

$$-2m = -10$$

$$\frac{-2m}{-2} = \frac{-10}{-2}$$

$$m = 5$$

Therefore, the length of the median  $DM$  is 5.

### EXTENSION:

In the solution we never used the fact that  $DM$  is a median and that  $EM = MF$ . This means that there could be other triangles that satisfy the conditions of the problem without  $DM$  being the median. Indeed there are! Try creating a few different triangles with  $DM = 5$  that satisfy all the conditions of the problem except the condition that  $DM$  is a median. You can do this using manipulatives, geometry software, or by hand. However, you may need some high school mathematics to calculate the precise dimensions.

It turns out that there is only one triangle that satisfies all the conditions of the problem including the fact that  $DM$  is a median.



## Problème de la semaine

### Problème C

#### Faire ses courses

Pendant qu'il fait ses courses, Terry estime le coût total de ses achats en estimant que chaque article coûtera 3,00 \$.

Un jour, Terry a acheté 20 articles. Chaque article qu'il a acheté coûtait soit 1,00 \$, soit 3,00 \$, soit 7,50 \$. Exactement sept des articles achetés coûtaient 3,00 \$. Si le coût total réel des 20 articles est le même que le coût total selon l'estimation de Terry, combien d'articles coûtaient 7,50 \$?





## Problem of the Week

### Problem C and Solution

### Gone Shopping

#### Problem

While grocery shopping, Terry has a way to approximate the total cost of his purchases. He simply approximates that each item will cost \$3.00.

One day, Terry purchased 20 items. He purchased items that each had an actual cost of either \$1.00, \$3.00, or \$7.50. Exactly seven of the purchased items had an actual cost of \$3.00. If the total actual cost of the 20 items was the same as the total approximated cost, how many items had an actual cost of \$7.50?

#### Solution

The total approximated cost for the 20 items is  $20 \times \$3 = \$60$ . Since the total actual cost is the same as the total approximated cost, the total actual cost for the 20 items is \$60. Since 7 of the items cost \$3.00, it cost Terry  $7 \times \$3 = \$21$  to buy these items. Therefore, the remaining  $20 - 7 = 13$  items cost  $\$60 - \$21 = \$39$ .

From this point, we will continue with two different solutions.

#### Solution 1

In this solution, we will use systematic trial-and-error to solve the problem.

Let  $s$  represent the number of items Terry bought with an actual cost of \$7.50 and  $d$  represent the number of items that Terry bought with an actual cost \$1.00. Then the total cost of the \$7.50 items would be  $7.5s$ . Also, the total cost of the \$1.00 items would be  $1d = d$ . Since Terry's total remaining cost was \$39, then  $7.5s + d = 39$ . We also know that  $s + d = 13$ .

At this point we can systematically pick values for  $s$  and  $d$  that add to 13 and substitute into the equation  $7.5s + d = 39$  to find the combination that works. (We can observe that  $s < 6$  since  $7.5 \times 6 = 45 > 39$ . If this were the case, then  $d$  would have to be a negative number.)

Let's start with  $s = 3$ . Then  $d = 13 - 3 = 10$ . The cost of these items would be  $7.5 \times 3 + 10 = 22.50 + 10 = \$32.50$ , which is less than \$39.

So let's try  $s = 4$ . Then  $d = 13 - 4 = 9$ . The cost of these items would be  $7.5 \times 4 + 9 = 30 + 9 = \$39$ , which is the amount we want.

Therefore, Terry purchased 4 items that cost \$7.50.



## Solution 2

In this solution, we will use algebra to solve the problem.

Let  $s$  represent the number of items that cost \$7.50. Therefore,  $(13 - s)$  represents the number of items that cost \$1.00. Also, the total cost of the \$7.50 items would be  $7.5s$ , the total cost of the \$1.00 items would be  $1 \times (13 - s) = 13 - s$ , and the total of these two is  $7.5s + 13 - s = 6.5s + 13$ .

Since Terry's total remaining cost was \$39.00, we must have

$$\begin{aligned}6.5s + 13 &= 39 \\6.5s + 13 - 13 &= 39 - 13 \\6.5s &= 26 \\ \frac{6.5s}{6.5} &= \frac{26}{6.5} \\s &= 4\end{aligned}$$

Therefore, Terry purchased 4 items that cost \$7.50.



## Problème de la semaine

### Problème C

#### Virée entre enseignants 1

Pour passer le temps lors d'un long trajet en bus, 35 enseignants de mathématiques ont créé une suite de nombres. À tour de rôle, chaque enseignant a dit un nombre de la suite. Le premier enseignant a dit le nombre 2, le deuxième enseignant a dit le nombre 8 et chaque enseignant après cela a dit la somme des deux termes précédents. Donc,

- le troisième enseignant a dit la somme des premier et deuxième termes, soit  $2 + 8 = 10$  et
- le quatrième enseignant a dit la somme des deuxième et troisième termes, soit  $8 + 10 = 18$ .

Après que le dernier enseignant a dit son nombre, le 25<sup>e</sup> enseignant a annoncé qu'il avait fait une erreur et que son nombre aurait dû être un de plus que celui qu'il avait dit. Quelle est la différence entre le nombre que le dernier enseignant a dit et celui qu'il aurait dit si le 25<sup>e</sup> enseignant n'avait pas fait d'erreur?





## Problem of the Week

### Problem C and Solution

#### Teacher Road Trip 1

#### Problem

To help pass time on a long bus ride, 35 math teachers created a sequence of numbers, with each teacher saying one term in the sequence. The first teacher said the number 2, the second teacher said the number 8, and every teacher after that said the sum of the two previous terms. Thus,

- the third teacher said the sum of the first and second terms, which is  $2 + 8 = 10$ , and
- the fourth teacher said the sum of the second and third terms, which is  $8 + 10 = 18$ .

Once the final teacher said their number, the 25<sup>th</sup> teacher announced they had made a mistake and their number should have been one more than what they had said. How much larger should the final teacher's number have been?

#### Solution

##### Solution 1

We will write out the sequence of numbers the teachers actually said, and then the sequence of numbers they should have said, and then find the difference between the last term in each sequence.

Here are the first 24 numbers that the teachers said:

2, 8, 10, 18, 28, 46, 74, 120, 194, 314, 508, 822, 1330, 2152, 3482, 5634, 9116, 14750, 23866, 38616, 62482, 101098, 163580, 264678

Here are the correct 25<sup>th</sup> to 35<sup>th</sup> numbers that the teachers should have said:

428258, 692936, 1121194, 1814130, 2935324, 4749454, 7684778, 12434232, 20119010, 32553242, 52672252

Here are the 25<sup>th</sup> to 35<sup>th</sup> numbers that the teachers actually said:

428257, 692935, 1121192, 1814127, 2935319, 4749446, 7684765, 12434211, 20118976, 32553187, 52672163

The difference between the correct and incorrect 35<sup>th</sup> number is  $52672252 - 52672163 = 89$ . Therefore, the 35<sup>th</sup> number was off by 89, and so the final teacher's number should have been 89 larger than the number they had said.





## Solution 2

In this solution we will solve the problem without actually calculating all the terms in the sequence.

We know the 25<sup>th</sup> term is off by 1. Therefore, the next terms will be as follows.

- The 26<sup>th</sup> term will also be off by 1 since it equals the sum of the 24<sup>th</sup> term (which is unchanged) and the 25<sup>th</sup> term (which is off by 1).
- The 27<sup>th</sup> term will be off by 2 since it is the sum of the 25<sup>th</sup> term (which is off by 1) and the 26<sup>th</sup> term (which is off by 1).
- The 28<sup>th</sup> term will be off by 3 since it is the sum of the 26<sup>th</sup> term (which is off by 1) and the 27<sup>th</sup> term (which is off by 2).

This pattern will continue on, so we can summarize it in a table.

Term Number	Amount Below the Correct Value
24	0
25	1
26	1
27	2
28	3
29	5
30	8
31	13
32	21
33	34
34	55
35	89

Therefore, the 35<sup>th</sup> term was off by 89, and so the final teacher's number should have been 89 larger than the number they had said.

Notice that the terms in the right column of the table follow the same rule as the original question. That is, each term is the sum of the previous two terms.

**FOR FURTHER THOUGHT:** The last 11 numbers in the right column of the table are the first 11 numbers of a famous sequence known as the Fibonacci Sequence. You may wish to investigate the Fibonacci Sequence further.



## Problème de la semaine

### Problème C

#### Quel est le pointage?

Dans le cours d'éducation physique, l'équipe jaune et l'équipe bleue ont joué au soccer. Ali ne se souvient pas du pointage final du match, mais elle a les renseignements suivants:

- Six buts ont été marqués au total.
- Aucune équipe n'a marqué plus de deux buts d'affilée à un moment donné du match.
- L'équipe bleue a remporté le match.

Détermine tous les pointages finaux possibles et les manières différentes dont chaque pointage aurait pu être obtenu.





## Problem of the Week

### Problem C and Solution

#### What's the Score?

#### Problem

In gym class, the yellow team and the blue team played soccer. Ali doesn't remember the final score of the game, but she does remember the following.

- There were six goals scored in total.
- Neither team scored more than two goals in a row at any point in the game.
- The blue team won the game.

Determine all the possible final scores and the different ways each score could have been obtained.

#### Solution

In order to win, the blue team must have scored more goals than the yellow team. Since there were six goals scored in total, the only possibilities for the final scores are  $4 - 2$ ,  $5 - 1$ , or  $6 - 0$  for the blue team.

Next we need to check which of these scores are possible, given that neither team scored more than two goals in a row at any point in the game.

- Is a final score of  $6 - 0$  possible?

We can easily eliminate  $6 - 0$ , since the blue team would have had to score more than two goals in a row.

- Is a final score of  $5 - 1$  possible?

This would mean that the blue team scored 5 goals and the yellow team scored 1 goal. Is there a way to arrange these goals so that the blue team didn't score two goals in a row? Let's look at all the possible arrangements, where  $B$  represents a goal for the blue team, and  $Y$  represents a goal for the yellow team. These are all shown below.

$YBBBBB$ ,  $BYBBBB$ ,  $BBYBBB$ ,  $BBBYBB$ ,  $BBBBYB$ ,  $BBBBBY$

As we can see, in all of these arrangements, the blue team scored more than two goals in a row. Thus, a final score of  $5 - 1$  is not possible.



- Is a final score of  $4 - 2$  possible?

This would mean that the blue team scored 4 goals and the yellow team scored 2 goals. Is there a way to arrange these goals so that the blue team didn't score two goals in a row? Let's look at all the possible arrangements, where  $B$  represents a goal for the blue team, and  $Y$  represents a goal for the yellow team.

- Case 1: The yellow team scored their 2 goals in a row. The possible arrangements are shown below.

*YYBBBB, BYYBBB, BBYYBB, BBBYYB, BBBBYY*

In this case, there is only 1 arrangement where neither team scored more than two goals in a row, namely *BBYYBB*.

- Case 2: The yellow team did not score their 2 goals in a row. The possible arrangements are shown below.

*YBYBBB, YBBYBB, YBBBYB, YBBBBY, BYBYBB, BYBBYB, BYBBBY, BBYBYB, BBYBBY, BBBYBY*

In this case, there are 5 arrangements where neither team scored more than two goals in a row, namely

*YBBYBB, BYBYBB, BYBBYB, BBYBYB, and BBYBBY.*

Therefore, the only possible final score is  $4 - 2$  for the blue team, and it could be obtained in the following six ways.

*BBYYBB, YBBYBB, BYBYBB, BYBBYB, BBYBYB, BBYBBY*



## Problème de la semaine

### Problème C

#### Les jetons de Thelma

Thelma a deux piles de jetons de bingo. Dans chaque pile, il y a des jetons verts et des jetons jaunes. Dans une pile, le rapport du nombre de jetons verts au nombre de jetons jaunes est de  $1 : 2$ . Dans la seconde pile, le rapport du nombre de jetons verts au nombre de jetons jaunes est de  $3 : 5$ . Si Thelma a un total de 20 jetons verts, détermine les possibilités pour le nombre total de jetons jaunes.





## Problem of the Week

### Problem C and Solution

#### Thelma's Chips

#### Problem

Thelma has two piles of bingo chips. In each pile there are green and yellow chips. In one pile, the ratio of the number of green chips to the number of yellow chips is  $1 : 2$ . In the second pile, the ratio of the number of green chips to the number of yellow chips is  $3 : 5$ . If Thelma has a total of 20 green chips, then determine the possibilities for the total number of yellow chips.

#### Solution

##### Solution 1

In this solution, we first look at all possible combinations of green and yellow chips in the second pile. Since the ratio of the number of green chips to the number of yellow chips in the second pile is  $3 : 5$ , we know that the number of green chips in this second pile must be a positive multiple of 3. We also know that there are at most 20 green chips in this pile. Thus, the only possible values for the number of green chips in the second pile are 3, 6, 9, 12, 15, and 18. Then, using the fact that the ratio of the number of green chips to the number of yellow chips is  $3 : 5$ , we can determine the number of yellow chips in the second pile for each case. We can also determine the number of green chips in the first pile by subtracting the number of green chips in the second pile from 20. Finally, we can determine the number of yellow chips in the first pile by multiplying the number of green chips in the first pile by 2. This information for each case is summarized in the table below.

Number of green chips in pile 2	Number of yellow chips in pile 2	Number of green chips in pile 1	Number of yellow chips in pile 1	Total number of yellow chips
3	5	$20 - 3 = 17$	34	$5 + 35 = 39$
6	10	$20 - 6 = 14$	28	$10 + 28 = 38$
9	15	$20 - 9 = 11$	22	$15 + 22 = 37$
12	20	$20 - 12 = 8$	16	$20 + 16 = 36$
15	25	$20 - 15 = 5$	10	$25 + 10 = 35$
18	30	$20 - 18 = 2$	4	$30 + 4 = 34$

Therefore, there are six possible values for the total number of yellow chips. There could be 34, 35, 36, 37, 38, or 39 yellow chips in total.



## Solution 2

Let  $a$  represent the number of green chips in the first pile, where  $a$  is a positive integer. Since the ratio of green chips to yellow chips in this pile is  $1 : 2$ , then there are  $2a$  yellow chips in this pile.

Let  $3b$  represent the number of green chips in the second pile, where  $b$  is a positive integer. Since the ratio of green chips to yellow chips in this pile is  $3 : 5$ , then there are  $5b$  yellow chips in this pile.

In total, there are 20 green chips, so  $a + 3b = 20$ . Also, the total number of yellow chips is equal to  $2a + 5b$ .

We consider all the possible values for positive integers  $a$  and  $b$  that satisfy the equation  $a + 3b = 20$ . Using these values of  $a$  and  $b$ , we can then find the possible values of  $2a + 5b$ , and hence the possible values for the total number of yellow chips.

The results are summarized in the table below.

$a + 3b$	$b$	$a$	$2a + 5b$
20	1	17	39
20	2	14	38
20	3	11	37
20	4	8	36
20	5	5	35
20	6	2	34

Therefore, there are six possible values for the total number of yellow chips. There could be 34, 35, 36, 37, 38, or 39 yellow chips in total.

---

# Gestion des données (D)

---







## Problème de la semaine

### Problème C

#### Collection de pièces de monnaie

Arya n'a jamais voyagé dans un autre pays, mais il possède une collection de pièces étrangères qui lui ont été données par des amis et des membres de sa famille qui ont voyagé. Sa collection comprend 10 pièces de monnaie provenant de l'Afrique, 6 pièces de monnaie provenant de l'Asie, 7 pièces de monnaie provenant de l'Amérique du Sud et 8 pièces de monnaie provenant de l'Europe.

Un jour, le grand-père d'Arya a ajouté quelques pièces australiennes à la collection. Après avoir fait cela, il a dit à Arya que s'il choisissait une pièce au hasard dans la collection, la probabilité pour qu'elle provienne de l'Afrique ou de l'Asie serait égale à  $\frac{4}{9}$ .

Combien de pièces australiennes le grand-père d'Arya a-t-il ajouté à la collection?





## Problem of the Week

### Problem C and Solution

### Coin Collection

#### Problem

Arya has never travelled to another country, but has a collection of foreign coins given to him by friends and family who have. In his collection he has 10 coins from Africa, 6 coins from Asia, 7 coins from South America, and 8 coins from Europe.

One day Arya's grandfather added some Australian coins to the collection. After he did that, he told Arya that if he took a coin at random from the collection, the probability of it being from either Africa or Asia was  $\frac{4}{9}$ .

How many Australian coins did Arya's grandfather add to the collection?

#### Solution

In order to determine the probability of a randomly selected coin being from either Africa or Asia, we divide the number of coins from Africa or Asia by the total number of coins in the collection. In other words,

$$\text{Probability of selecting a coin from Africa or Asia} = \frac{\text{Number of coins from Africa or Asia}}{\text{Total number of coins}}$$

From here we will present two different solutions to this problem.

#### Solution 1

When Arya's grandfather adds Australian coins to the collection, this does not change the number of coins from Africa or Asia. Therefore the number of coins from Africa or Asia in the collection is  $10 + 6 = 16$ . We are also told that the probability of drawing a coin from Africa or Asia is  $\frac{4}{9}$ . We can substitute these values into our equation.

$$\begin{aligned} \text{Probability of selecting a coin from Africa or Asia} &= \frac{\text{Number of coins from Africa or Asia}}{\text{Total number of coins}} \\ \frac{4}{9} &= \frac{16}{\text{Total number of coins}} \end{aligned}$$

Since  $\frac{4}{9} = \frac{16}{36}$ , it follows that

$$\frac{16}{36} = \frac{16}{\text{Total number of coins}}$$

Therefore, the total number of coins in the collection is 36.

Originally there were  $10 + 6 + 7 + 8 = 31$  coins in the collection, and then Arya's grandfather added some Australian coins. Since there were 36 coins in the collection after the Australian coins were added, it follows that Arya's grandfather must have added  $36 - 31 = 5$  Australian coins to the collection.

**Solution 2**

This solution uses algebra, which may be beyond what some students at this level are familiar with.

Let  $n$  represent the number of Australian coins that Arya's grandfather added to the collection. Then the number of coins from Africa or Asia in the collection is  $10 + 6 = 16$ , and the total number of coins in the collection is  $10 + 6 + 7 + 8 + n = 31 + n$ . We are also told that the probability of drawing a coin from Africa or Asia is  $\frac{4}{9}$ . We can substitute these values into our equation.

$$\begin{aligned} \text{Probability of selecting a coin from Africa or Asia} &= \frac{\text{Number of coins from Africa or Asia}}{\text{Total number of coins}} \\ \frac{4}{9} &= \frac{16}{31 + n} \end{aligned}$$

Since  $4 \times 4 = 16$ , it follows that  $9 \times 4 = 31 + n$ . We can simplify and solve this equation to find the value of  $n$ .

$$\begin{aligned} 9 \times 4 &= 31 + n \\ 36 &= 31 + n \\ 36 - 31 &= n \\ 5 &= n \end{aligned}$$

Therefore, Arya's grandfather added 5 Australian coins to the collection.



## Problème de la semaine

### Problème C

#### Jeu équitable ?

Dans le cadre d'un projet scolaire de mathématiques, Zesiro et Magomu ont créé un jeu qui utilise deux paquets de cartes spéciaux comportant six cartes chacun. Les cartes d'un paquet portent les nombres pairs 2, 4, 6, 8, 10 et 12, tandis que les cartes de l'autre paquet portent les nombres impairs 1, 3, 5, 7, 9 et 11.

Au cours d'un tour, Zesiro choisit au hasard une carte parmi celles qui portent un nombre pair et Magomu choisit au hasard une carte parmi celles qui portent un nombre impair. Ces deux cartes forment une paire de cartes. Après avoir choisi une paire de cartes, ils effectuent les étapes suivantes :

1. Ils déterminent la somme,  $S$ , des nombres inscrits sur les cartes. Par exemple, si Zesiro choisit la carte portant le nombre 6 et que Magomu choisit la carte portant le nombre 3, alors  $S = 6 + 3 = 9$ .
2. Ensuite, ils déterminent  $D$ , soit la somme des chiffres de  $S$ . Si  $S$  est un nombre à un chiffre, alors  $D$  est égal à  $S$ . Si  $S$  est un nombre à deux chiffres, alors  $D$  est égal à la somme de ces deux chiffres. Par exemple, si Zesiro choisit la carte portant le nombre 6 et Magomu la carte portant le nombre 3, alors  $S$  et  $D$  sont tous deux égaux à 9. Si Zesiro choisit la carte portant le nombre 10 et Magomu la carte portant le nombre 5, alors  $S$  est égal à  $S = 10 + 5 = 15$ , d'où  $D$  est donc égal à  $D = 1 + 5 = 6$ . Si Zesiro choisit la carte portant le nombre 10 et Magomu la carte portant le nombre 9, alors  $S$  est égal à  $S = 10 + 9 = 19$ , d'où  $D$  est donc égal à  $D = 1 + 9 = 10$ .

Zesiro gagne un point si la somme des chiffres,  $D$ , est un multiple de 4.

Magomu gagne un point si le nombre figurant sur l'une des cartes est un multiple du nombre figurant sur l'autre carte.

Ce jeu est-il équitable ? Autrement dit, est-ce que Zesiro et Magomu ont la même probabilité de gagner un point à chaque tour ? Justifie ta réponse.

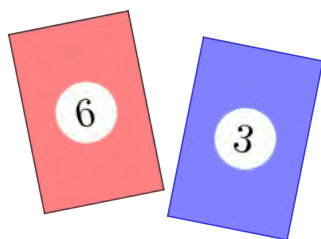

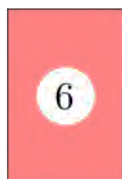

## Problem of the Week

### Problem C and Solution

#### Fair Game?



#### Problem

For a school mathematics project, Zesiro and Magomu created a game that uses two special decks of six cards each. The cards in one deck are labelled with the even numbers 2, 4, 6, 8, 10, and 12, and the cards in the other deck are labelled with the odd numbers 1, 3, 5, 7, 9, and 11.

A turn consists of Zesiro randomly choosing a card from the deck with even-numbered labels and Magomu randomly choosing a card from the deck with odd-numbered labels. These two cards make a pair of cards. After a pair of cards is chosen, they perform the following steps.

1. They determine the sum,  $S$ , of the numbers on the cards. For example, if Zesiro chooses the card labelled with a 6 and Magomu chooses the card labelled with a 3, then  $S = 6 + 3 = 9$ .
2. Using  $S$ , they determine,  $D$ , the digit sum. If  $S$  is a single digit number, then  $D$  is equal to  $S$ . If  $S$  is a two-digit number, then  $D$  is the sum of the two digits of  $S$ . For example, if Zesiro chooses the card labelled with a 6 and Magomu chooses the card labelled with a 3, then the sum and the digit sum are both 9. If Zesiro chooses the card labelled with a 10 and Magomu chooses the card labelled with a 5, then the sum is  $S = 10 + 5 = 15$  and the digit sum is  $D = 1 + 5 = 6$ . If Zesiro chooses the card labelled with a 10 and Magomu chooses the card labelled with a 9, then the sum is  $S = 10 + 9 = 19$  and the digit sum is  $D = 1 + 9 = 10$ .

Zesiro gets a point if the digit sum,  $D$ , is a multiple of 4.

Magomu gets a point if the number on one of the cards is a multiple of the number on the other card.

Is this game fair? That is, do Zesiro and Magomu have the same probability of getting a point on any turn? Justify your answer.

#### Solution

To solve this problem, we will create a table where the columns show the possible choices for the even-numbered card, the rows show the possible choices for the odd-numbered card, and each cell in the body of the table gives the sum of the corresponding pair of cards.

		Even Card					
		2	4	6	8	10	12
Odd Card	1	3	5	7	9	11	13
	3	5	7	9	11	13	15
	5	7	9	11	13	15	17
	7	9	11	13	15	17	19
	9	11	13	15	17	19	21
	11	13	15	17	19	21	23



From the table, we see that the total number of possible pairs is  $6 \times 6 = 36$ .

We create another table where the columns show the possible choices for the even-numbered card, the rows show the possible choices for the odd-numbered card, and each cell in the body of the table gives the digit sum of the corresponding pair of cards.

		Even Card					
		2	4	6	8	10	12
Odd Card	1	3	5	7	9	$1 + 1 = 2$	$1 + 3 = 4$
	3	5	7	9	$1 + 1 = 2$	$1 + 3 = 4$	$1 + 5 = 6$
	5	7	9	$1 + 1 = 2$	$1 + 3 = 4$	$1 + 5 = 6$	$1 + 7 = 8$
	7	9	$1 + 1 = 2$	$1 + 3 = 4$	$1 + 5 = 6$	$1 + 7 = 8$	$1 + 9 = 10$
	9	$1 + 1 = 2$	$1 + 3 = 4$	$1 + 5 = 6$	$1 + 7 = 8$	$1 + 9 = 10$	$2 + 1 = 3$
	11	$1 + 3 = 4$	$1 + 5 = 6$	$1 + 7 = 8$	$1 + 9 = 10$	$2 + 1 = 3$	$2 + 3 = 5$

If the digit sum is a multiple of 4, then Zesiro gets a point. In the table there are two digit sums, 4 and 8, that are multiples of 4. The digit sum 4 occurs six times in the table and the digit sum 8 occurs four times in the table. This totals ten possible outcomes for Zesiro, and so his probability of scoring a point on any pair is  $\frac{10}{36}$ .

Magomu has far less work to determine when he gets a point. None of the odd numbers are multiples of the even numbers. All multiples of even numbers are even and hence will never be odd.

Whenever a 1 is chosen, Magomu will score a point. That is, each of the six even numbers is a multiple of 1.

When a 3 is chosen, Magomu will score a point if the number on the face of the even-numbered card is a 6 or 12. That is, only two of the even numbers are multiples of 3.

When a 5 is chosen, Magomu will score a point if the number on the face of the even-numbered card is a 10. That is, only one of the even numbers is a multiple of 5.

None of the numbers in the deck containing only even numbers is a multiple of 7, 9, or 11.

So Magomu will score a point on  $6 + 2 + 1 = 9$  of the 36 possible pairs. Therefore, Magomu's probability of scoring a point on any pair is  $\frac{9}{36}$ .

The game is not fair since Zesiro's probability of scoring a point on any pair is greater than Magomu's probability of scoring a point on any pair.



## Problème de la semaine

### Problème C

#### Bien équilibré

La moyenne, la médiane et l'unique mode des cinq nombres 15, 12, 14, 19, et  $n$  sont tous égaux. Détermine la valeur de  $n$ .

15                      14                       $n$   
                                 12                      19

15 12 14 19  $n$ 

## Problem of the Week

### Problem C and Solution

#### Same Same

#### Problem

The mean (average), the median, and the only mode of the five numbers 15, 12, 14, 19, and  $n$  are all equal. Determine the value of  $n$ .

#### Solution

For the five numbers 15, 12, 14, 19, and  $n$  to have a single mode,  $n$  must equal one of the existing numbers in the list: 15, 12, 14, or 19. It follows that the mean (average), median, and mode must all equal  $n$ .

Since there five numbers, and five is an odd number, the median will be equal to the number in the middle position when the five numbers are written in increasing order. When we write the existing numbers in increasing order, we obtain 12, 14, 15, 19. Since  $n$  is equal to the median, and must also equal one of the existing numbers, the only possibilities are  $n = 14$  or  $n = 15$ .

If  $n = 14$ , then the mean of the five numbers is  $\frac{12 + 14 + 14 + 15 + 19}{5} = 14.8$ , which is not equal to 14.

If  $n = 15$ , then the mean of the five numbers is  $\frac{12 + 14 + 15 + 15 + 19}{5} = 15$ .

Then the mean, median, and mode are all equal to 15. Therefore, the value of  $n$  is 15.



---

# Raisonnement informatiques (C)

---





## Problème de la semaine

### Problème C

#### La traversée des canaux

Koji est en train de ramer sur un réseau de canaux très fréquenté près de chez lui. Dans la figure ci-dessous, on voit le réseau de canaux. L'étoile représente l'emplacement actuel de Koji et la maison représente l'emplacement de sa maison.

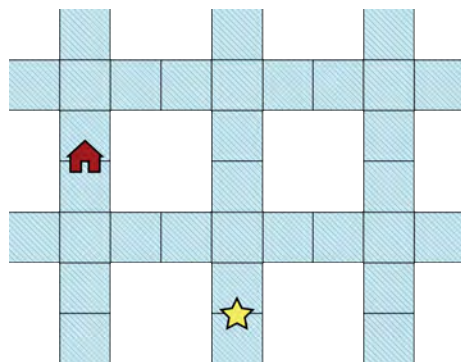

Ayant souvent ramé dans le réseau de canaux, Koji sait:

1. Qu'il faut 30 secondes pour traverser une case d'intersection en ramant en ligne droite.
2. Qu'il faut 20 secondes pour traverser une case qui n'est pas une intersection en ramant en ligne droite.
3. Que de tourner à droite à une intersection prend 15 secondes.
4. Que de tourner à gauche à une intersection prend 270 secondes, en raison du trafic intense.
5. Qu'il n'est pas possible de faire demi-tour ou d'inverser la direction.

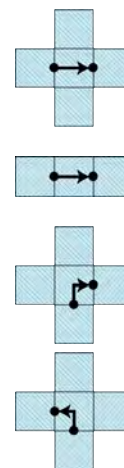

Calcule le temps le plus court qu'il faudra à Koji pour ramer jusqu'à chez lui depuis sa position actuelle, en utilisant uniquement les canaux indiqués.

**Tu n'arrives pas à imprimer cette page?** Essaie notre [feuille de travail interactive](#).

Ce problème s'inspire d'un autre problème qui figurait dans un des concours précédents du [défi informatique Beaver](#)



## Problem of the Week

### Problem C and Solution

### Crossing Canals

#### Problem

Koji is rowing his boat on a busy canal system near his home. The following diagram shows the canal system with a star representing Koji's current location and the house representing the location of his home.

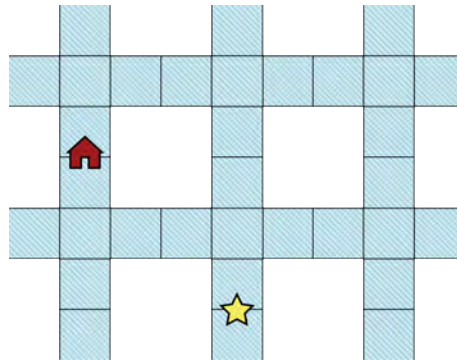

From Koji's extensive canal experience, he knows the following:

1. Rowing straight across an intersection square takes 30 seconds.
2. Rowing straight across a square that is not an intersection takes 20 seconds.
3. Turning right at an intersection takes 15 seconds.
4. Turning left at an intersection takes 270 seconds, due to heavy traffic.
5. It is not possible make U-turns or reverse direction.

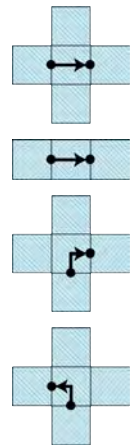

Calculate the shortest amount of time it will take Koji to row home from his current position, using only the canals shown.

**Not printing this page?** You can use our [interactive worksheet](#).

#### Solution

Let  $R$  represent a right turn,  $L$  represent a left turn,  $X$  represent a move straight across an intersection square, and  $N$  represent a move straight across a non-intersection square.



We will now consider different routes and calculate the rowing time for each.

- The shortest route by distance is shown.

This corresponds to  $N \rightarrow L \rightarrow N \rightarrow N \rightarrow R \rightarrow N$ .

Using the given times it would take

$$4 \times 20 + 1 \times 270 + 1 \times 15 = 365 \text{ seconds.}$$

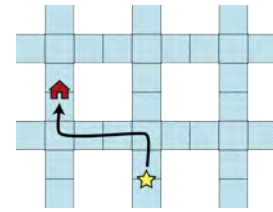

- A second route is shown. This corresponds to  $N \rightarrow X \rightarrow N \rightarrow N \rightarrow L \rightarrow N \rightarrow N \rightarrow L \rightarrow N$ .

Using the given times it would take

$$6 \times 20 + 2 \times 270 + 1 \times 30 = 690 \text{ seconds. This route is longer than the first and takes much more time.}$$

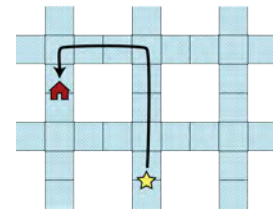

- A third route is shown. This corresponds to  $N \rightarrow X \rightarrow N \rightarrow N \rightarrow R \rightarrow N \rightarrow N \rightarrow R \rightarrow N \rightarrow N \rightarrow R \rightarrow N \rightarrow N \rightarrow X \rightarrow N \rightarrow N \rightarrow R \rightarrow N$ .

Using the given times it would take

$$12 \times 20 + 2 \times 30 + 4 \times 15 = 360 \text{ seconds. This route is longer than the previous two, but takes the least amount of time, so far.}$$

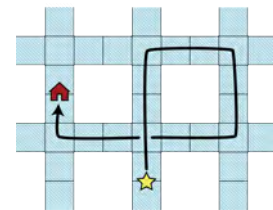

- A fourth route is shown. This corresponds to  $N \rightarrow R \rightarrow N \rightarrow N \rightarrow L \rightarrow N \rightarrow N \rightarrow L \rightarrow N \rightarrow N \rightarrow L \rightarrow N \rightarrow N \rightarrow R \rightarrow N \rightarrow N \rightarrow R \rightarrow N$ .

Using the given times it would take

$$12 \times 20 + 3 \times 15 + 3 \times 270 = 1095 \text{ seconds. This route takes much longer than the previous routes, due to all the left turns.}$$

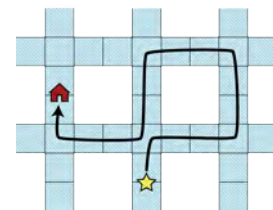

- A fifth route is shown. This corresponds to  $N \rightarrow R \rightarrow N \rightarrow N \rightarrow L \rightarrow N \rightarrow N \rightarrow L \rightarrow N \rightarrow N \rightarrow X \rightarrow N \rightarrow N \rightarrow L \rightarrow N$ .

Using the given times it would take

$$10 \times 20 + 1 \times 15 + 3 \times 270 + 1 \times 30 = 1055 \text{ seconds. This route also takes more time than the third route.}$$

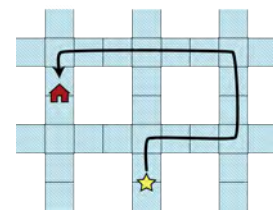

There are other routes that could be checked out but they include at least one of the above routes, so would not be the fastest.

Therefore, the shortest amount of time it will take Koji to row home is 360 seconds.



## Problème de la semaine

### Problème C

#### Construire une communauté

Une île contient douze petits villages qui sont reliés par des routes, comme on le voit dans la figure ci-dessous. Les villages sont désignés par les lettres A à L et les routes reliant les villages sont représentées par des segments de droites.

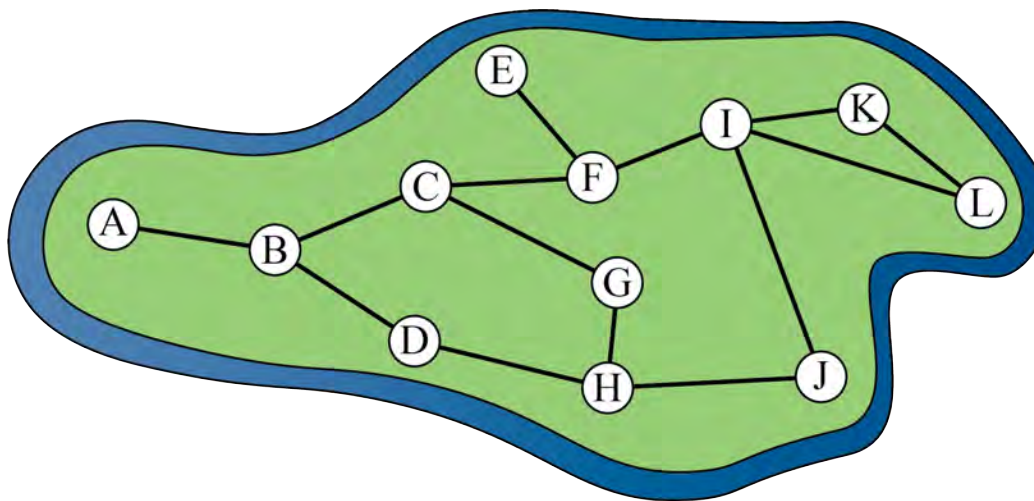

Le maire de l'île compte construire des centres communautaires dans certains villages afin que chaque village ait son propre centre communautaire ou soit relié par une seule route à un village qui a un centre communautaire.

- Si le maire choisit de construire cinq centres communautaires, quels sont les cinq villages qu'il pourrait choisir ?
- Quel est le plus petit nombre de centres communautaires que le maire doit construire ?

Ce problème s'inspire d'un autre problème qui figurait dans un des concours précédents du [défi informatique Beaver](#).



## Problem of the Week

### Problem C and Solution

#### Building Community

#### Problem

An island contains twelve small towns that are connected by roads as shown in the diagram below. The towns are labelled with the letters A through L and the roads connecting the towns are indicated by line segments.

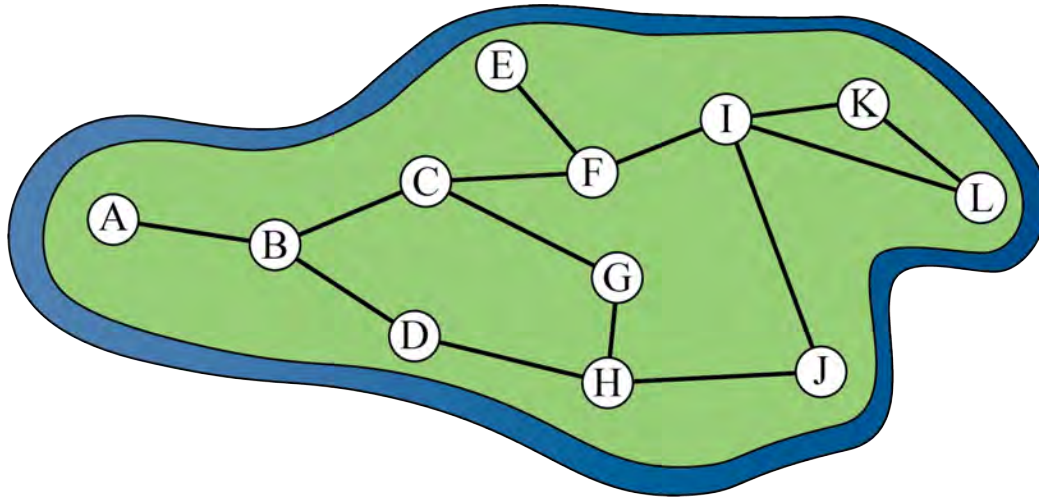

The mayor of the island is going to build community centres in some of the towns so that each town either has its own community centre, or is connected by a single road to a town that has a community centre.

- (a) If the mayor chooses to build five community centres, which five towns could the mayor choose?
- (b) What is the fewest number of community centres the mayor needs to build?

This problem was inspired by a past [Beaver Computing Challenge \(BCC\)](#) problem.

#### Solution

- (a) There are many possible answers. Two possibilities are shown below, where the chosen towns are circled.

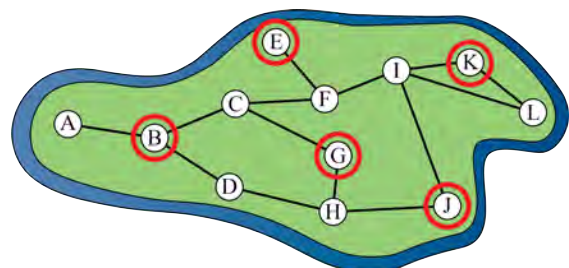
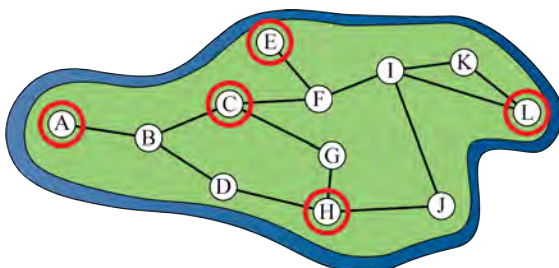



- (b) There are two towns that have only one road leading out of them, namely towns  $A$  and  $E$ . Since each town must either have its own community centre or be connected by a single road to a town that has a community centre, we need to put one community centre in town  $A$  or  $B$ , and another community centre in town  $E$  or  $F$ . Since towns  $B$  and  $F$  are connected to other towns as well, they are the better choices if we want to build the fewest number of community centres.

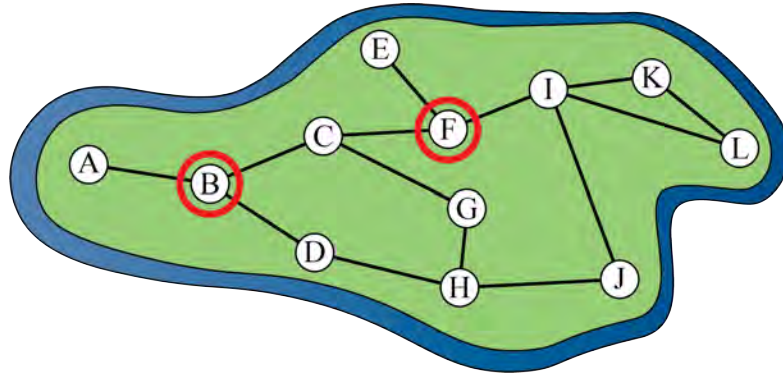

After choosing towns  $B$  and  $F$ , the remaining towns that don't have their own community centre and are not connected by a single road to a town that has a community centre are towns  $G$ ,  $H$ ,  $J$ ,  $K$ , and  $L$ . None of these five towns are connected to all the others, and there is no town that is connected to all five of the towns. So we need at least two more community centres to cover the remaining five towns. Choosing towns  $K$  and  $H$  would work.

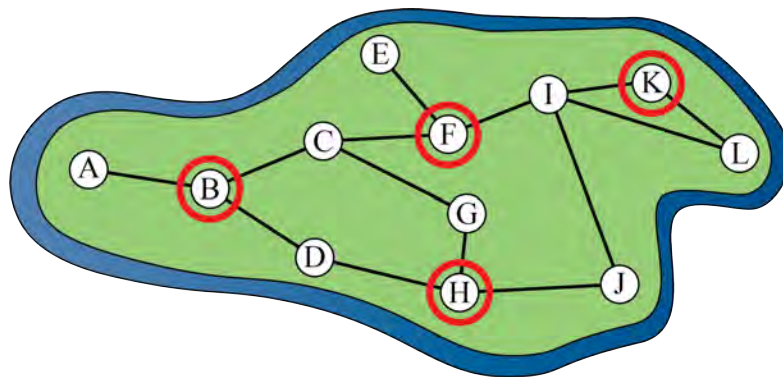

Therefore, the fewest number of community centres the mayor needs to build is four.

Note that this is not the only group of four towns that we could have chosen. There are several other possibilities.



## Problème de la semaine

### Problème C

#### Ajouter un peu de couleur

Martina et Zahra jouent à un jeu qui consiste à ombrer à tour de rôle les régions du diagramme ci-dessous.

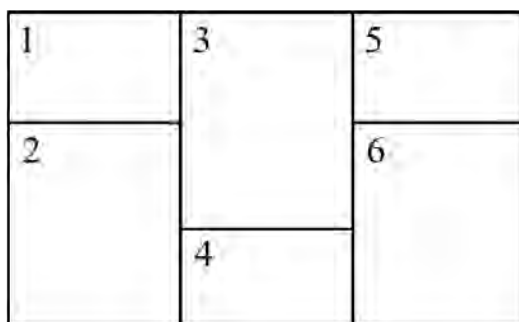

À son tour, chaque joueuse ombre une région du diagramme qui n'est pas bordée par une autre région ombrée. Après un certain nombre de tours, il ne sera plus possible d'ombrer d'autres régions et la partie sera terminée. La vainqueuse est la joueuse qui a ombré la dernière région.

Supposons que Martina soit la première joueuse à ombrer une région. Deux des six régions sont telles que si elle ombre l'une d'entre elles à son premier tour, elle peut garantir une victoire, peu importe les choix de Zahra lors de ses tours restants. De quelles régions s'agit-il ?





## Problem of the Week

### Problem C and Solution

#### Adding Some Colour 1

#### Problem

Martina and Zahra play a game where they take turns shading regions in the diagram shown.

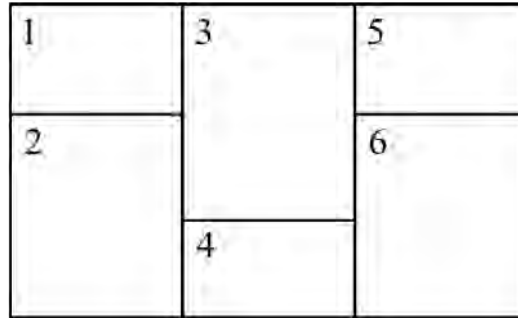

On their turn, each player shades a region in the diagram that is not bordering another shaded region. After some number of turns, it won't be possible to shade any more regions, and the game will be over. The winner is the player who shaded the last region.

Suppose Martina is the first player to shade a region. Two of the six regions are such that if she shades one of them on her first turn, then she can guarantee that she wins the game, regardless of what Zahra does on her turns. Which two regions are they?

#### Solution

Shading region 3 or region 4 first will guarantee that Martina wins the game. First we will show why this is true, and then we will show why shading any of the other regions first will not guarantee a win for Martina.

Notice that every region in the diagram borders region 3. So if Martina starts by shading region 3 then it will not be possible to shade any other region and the game will be over. Zahra will not even have a chance to take a turn and Martina will win the game.

Now, if Martina starts by shading region 4, then since regions 2, 3, and 6 border region 4, Zahra will not be able to shade these regions. The only regions that Zahra will be able to shade are regions 1 or 5. Since these regions are not bordering each other, Zahra will shade one of these regions, then Martina will shade the other region and win the game.

Thus, we have shown that shading either region 3 or region 4 first will guarantee a win for Martina.

If Martina started by shading region 1, then Zahra would not be able to shade regions 2 or 3, so she would be left to choose between shading region 4, 5, or 6.



Since region 6 borders regions 4 and 5, if Zahra shaded region 6 then Martina would not be able to shade any regions and Zahra would win the game. Thus, shading region 1 first does not guarantee a win for Martina.

Similarly, if Martina started by shading region 5, then Zahra would not be able to shade regions 3 or 6, so she would be left to choose between shading region 1, 2, or 4. Since region 2 borders regions 1 and 4, if Zahra shaded region 2 then Martina would not be able to shade any regions and Zahra would win the game. Thus, shading region 5 first does not guarantee a win for Martina.

If Martina started by shading region 2, then Zahra would not be able to shade regions 1, 3, or 4, so she would be left to choose between shading region 5 or 6. Since regions 5 and 6 border each other, if Zahra shaded either one of them it would not be possible for Martina to shade any regions and Zahra would win the game. Thus, shading region 2 first does not guarantee a win for Martina.

Similarly, if Martina started by shading region 6, then Zahra would not be able to shade regions 3, 4, or 5, so she would be left to choose between shading region 1 or 2. Since regions 1 and 2 border each other, if Zahra shaded either one of them it would not be possible for Martina to shade any regions and Zahra would win the game. Thus, shading region 6 first does not guarantee a win for Martina.

Therefore, regions 3 and 4 are the only regions that Martina can shade first in order to guarantee that she wins the game, regardless of what Zahra does on her turns.