



The CENTRE for EDUCATION  
in MATHEMATICS and COMPUTING  
*cemc.uwaterloo.ca*

## ***2024 Team Up Challenge***

June 2024

*Answer Keys*



## 2024 Team Up Challenge

### Team Paper Answer Key

Question	Answer
1	9
2	36
3	36
4	45
5	192
6	5
7	18
8	3
9	29
10	13
11	40
12	2009
13	42
14	8
15	$\frac{1}{16}$



## 2024 Team Up Challenge

### Crossnumber Puzzle Answer Key

	5	9	9		4	5	5	2
7	2		1	1	3			2
	2			5		6	6	0
2	5		6	6	7		4	
3		2	9		8	5		6
	2		1	5	9		3	1
2	6	4		1			8	
3			1	0	1		5	8
7	4	4	8		9	6	1	



# 2024 Team Up Challenge

## Logic Puzzle Answer Key

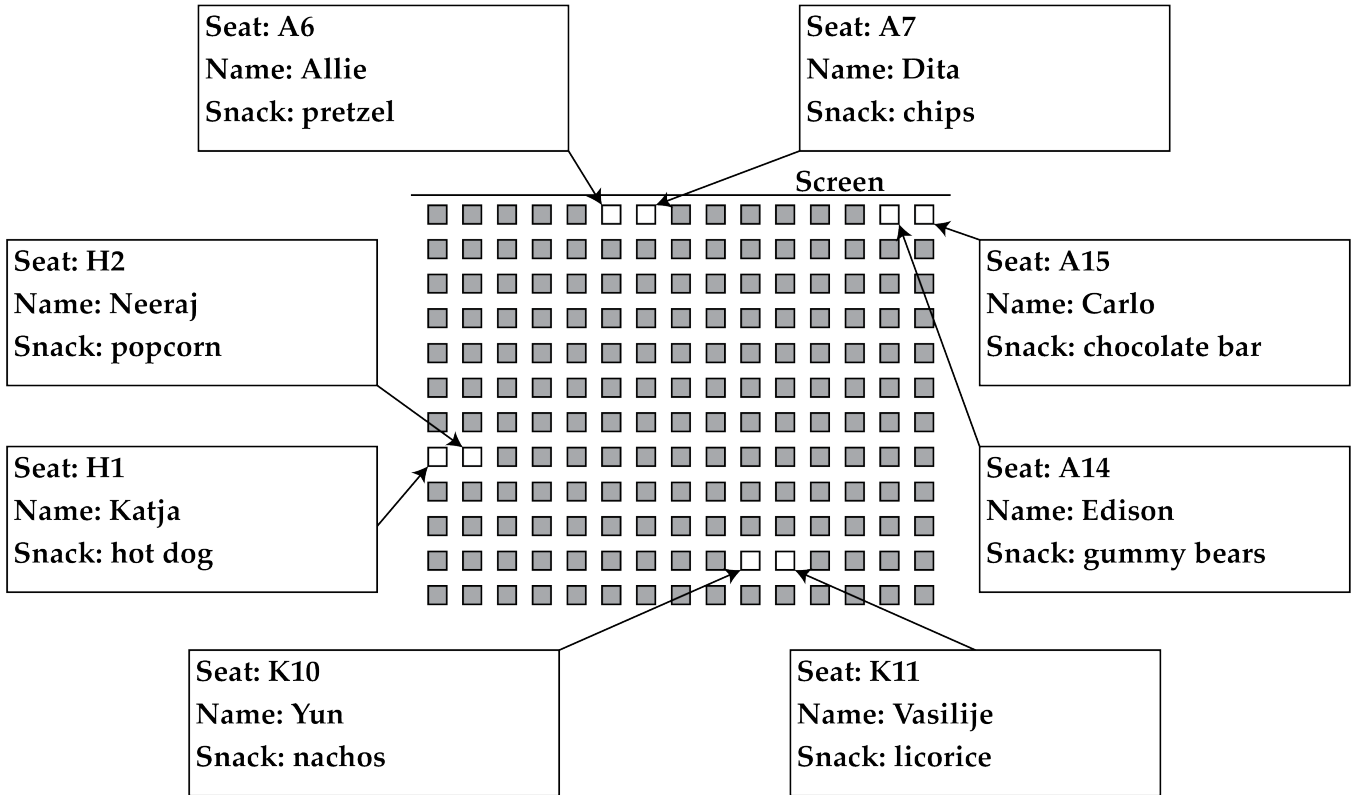



## 2024 Team Up Challenge

### Relay Answer Key

Practice Relay				
	Player 1	Player 2	Player 3	Player 4
Answer	11	20	70	75

Relay A				
	Player 1	Player 2	Player 3	Player 4
Answer	26	24	60	900

Relay B				
	Player 1	Player 2	Player 3	Player 4
Answer	12	4	$\frac{17}{20}$	17

Relay C				
	Player 1	Player 2	Player 3	Player 4
Answer	22	6	27	15.25



The CENTRE for EDUCATION  
in MATHEMATICS and COMPUTING  
*cemc.uwaterloo.ca*

## *2024 Team Up Challenge*

June 2024

*Solutions*

**Team Paper**

1. Since  $a + b = 6$  and  $a = b$ , it follows that  $a = b = 3$ . Then  $a \times b = 3 \times 3 = 9$ .

ANSWER: 9

2. Since  $25\% \times 3 = 75\%$ , it follows that 3 times as many people chose mystery compared to fantasy. So the number of people who chose mystery is  $3 \times 12 = 36$ .

ANSWER: 36

3. *Solution 1*

Since the area of 5 of the smaller squares is  $20 \text{ m}^2$ , then each of the smaller squares has an area of  $20 \div 5 = 4 \text{ m}^2$ . Thus, the area of the large square is  $9 \times 4 = 36 \text{ m}^2$ .

*Solution 2*

Since the area of 5 of the smaller squares is  $20 \text{ m}^2$ , then each of the smaller squares has an area of  $20 \div 5 = 4 \text{ m}^2$ . So the side length of each of the smaller squares is  $\sqrt{4} = 2 \text{ m}$ . Then the side length of the large square is  $3 \times 2 = 6 \text{ m}$ . The area of the large square is then  $6 \times 6 = 36 \text{ m}^2$ .

ANSWER: 36

4. If Antonio swam 5 laps, then Britt swam  $2 \times 5 = 10$  laps. Then Caitlin swam  $3 \times 10 = 30$  laps. Thus, the total number of laps swum by all three people is  $5 + 10 + 30 = 45$ .

ANSWER: 45

5. We start with the output, which is 8, and work backwards, through the machine. Before subtracting 10, this value would have been  $8 + 10 = 18$ . Before dividing by 3, this value would have been  $18 \times 3 = 54$ . Before subtracting 10, this value would have been  $54 + 10 = 64$ . Before dividing by 3, this value would have been  $64 \times 3 = 192$ . Thus, the input was 192.

ANSWER: 192

6. Since Alpha can see exactly 9 eyes, it follows that the sum of Beta's and Gamma's eyes is 9. There are eight different ways that Beta's and Gamma's eyes can have a sum of 9, as shown.

Beta's Eyes	1	2	3	4	5	6	7	8
Gamma's Eyes	8	7	6	5	4	3	2	1

Since Beta sees 3 more eyes than Gamma, and they both see Alpha's eyes, it follows that Gamma must have 3 more eyes than Beta. From our table, there is only one pair of numbers that works, and it must be the case that Gamma has 6 eyes and Beta has 3 eyes.

If Beta sees 11 eyes, and we know Gamma has 6 eyes, then it follows that Alpha must have 5 eyes. For completeness, we can check that Gamma sees  $5 + 3 = 8$  eyes, as desired.

ANSWER: 5



7. *Solution 1*

For every possible digit for  $A$ , if  $B < 5$ , then  $6A \times B < 300$ . So,  $B \geq 5$ . For every possible digit for  $A$ , if  $B > 6$  then  $6A \times B > 400$ . So  $B \leq 6$ . Thus,  $B = 5$  or  $B = 6$ . However,  $6A \times 5$  would have a ones digit of 0 or 5, but we know the ones digit is 4. So  $B = 6$ .

If  $B = 6$  then  $A = 4$  and  $A = 9$  are the only values that result in a ones digit of 4 after multiplying. Testing both values, we find that  $64 \times 6 = 384$  and  $69 \times 6 = 414$ . Only one of these results has a hundreds digit of 3, and so  $A = 4$  and  $C = 8$ . Thus,  $A + B + C = 4 + 6 + 8 = 18$ .

*Solution 2*

We know that the product of  $A$  and  $B$  must have a units digit of 4. Since  $A$  and  $B$  are both digits, we can find all the pairs of digits whose product has a units digit of 4. These are  $1 \times 4 = 4$ ,  $2 \times 2 = 4$ ,  $2 \times 7 = 14$ ,  $3 \times 8 = 24$ ,  $4 \times 6 = 24$ ,  $6 \times 9 = 54$ , and  $8 \times 8 = 64$ .

After trying each pair of digits as  $A$  and  $B$ , we can conclude that  $A = 4$  and  $B = 6$ . It follows that  $C = 8$ . Thus,  $A + B + C = 4 + 6 + 8 = 18$ .

ANSWER: 18

8. First we draw the smallest possible rectangle around the frog, so that the sides of the rectangle lie on grid lines. Then we move the rectangle 5 units up, as shown.

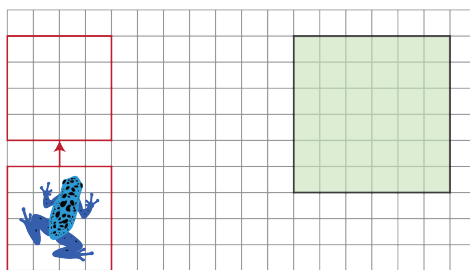

If we move the rectangle 11 units to the right, then its left side will be aligned with the left side of the square. Thus, 11 is the smallest possible value of  $x$ . If we move the rectangle 13 units to the right, then its right side will be aligned with the right side of the square. Thus, 13 is the largest possible value of  $x$ . Since  $x$  is an integer, it can be 11, 12, or 13. Therefore there are 3 possible values of  $x$ .

ANSWER: 3

9. First we will label the rocks as shown.

The turtle starts at rock  $A$  facing to the right. Since the score = 0, the turtle will move forward to rock  $B$ , and the new score will be 4.

Since the score is even, the turtle will turn right, move forward to rock  $F$ , and the new score will be  $4 + 3 = 7$ .

Since the score is odd, the turtle will turn left, move forward to rock  $G$ , and the new score will be  $7 + 2 = 9$ .

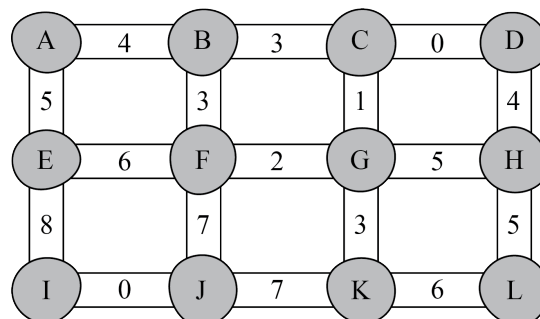





Since the score is odd, the turtle will turn left, move forward to rock  $C$ , and the new score will be  $9 + 1 = 10$ .

Since the score is even, the turtle will turn right, move forward to rock  $D$ , and the new score will be  $10 + 0 = 10$ .

Since the score is even, the turtle will turn right, move forward to rock  $H$ , and the new score will be  $10 + 4 = 14$ .

Since the score is even, the turtle will turn right, move forward to rock  $G$ , and the new score will be  $14 + 5 = 19$ .

Since the score is odd, the turtle will turn left, move forward to rock  $K$ , and the new score will be  $19 + 3 = 22$ .

Since the score is even, the turtle will turn right, move forward to rock  $J$ , and the new score will be  $22 + 7 = 29$ .

Since the score is odd, the turtle will turn left, and try to move forward, however since there is no path in front of it, the program will crash. Thus, Ahmed's score right before his program crashed was 29.

ANSWER: 29

10. Since the blocks must all fit inside the box, then the total volume of all the blocks must be less than or equal to the volume of the box.

The volume of the box is  $3 \times 3 \times 3 = 27$ . Since each block has a volume of  $1 \times 1 \times 2 = 2$ , then at most  $27 \div 2 = 13.5$  blocks can fit. However, we can't have half a block, so based on volume, we can theoretically fit at most 13 blocks inside the box.

Given the dimensions of the blocks and box, can we actually fit 13 blocks into the box? First we arrange four blocks laying flat, as shown.

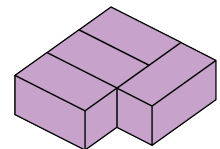

Then we stack two blocks directly on top of each of the four blocks. This will create a  $3 \times 3 \times 3$  cube with an empty  $1 \times 1 \times 3$  space in the corner, where we can place one additional block. This will allow us to fit  $4 \times 3 + 1 = 13$  blocks, as desired.

ANSWER: 13

11. We begin by labelling additional points, as shown, and then proceed with two different solutions.

*Solution 1*

One way we can approach this problem is to choose some values that satisfy the perimeters given.

If the perimeter of the shaded rectangle  $AEJH$  is 28 cm, then this rectangle could have  $AE = HJ = 8$  cm and  $AH = EJ = 6$  cm. Similarly, if the perimeter of the striped rectangle  $JFCG$  is 12 cm, then this rectangle could have  $JF = GC = 4$  cm and  $JG = FC = 2$  cm.

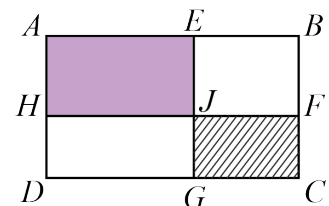



Since  $ABCD$  is divided into four rectangles,  $AB$  and  $HF$  are parallel and equal in length. So,  $AB = HF = HJ + JF = 8 + 4 = 12$  cm. Since  $ABCD$  is a rectangle,  $DC = AB = 12$  cm. Similarly,  $AD = EG = EJ + JG = 6 + 2 = 8$  cm and  $BC = AD = 8$  cm.

Therefore, the perimeter of the rectangle  $ABCD$  is equal to  $AB + BC + DC + AD = 12 + 8 + 12 + 8 = 40$  cm.

*Solution 2*

Here we use variables to represent the unknown side lengths. Let  $AE = HJ = w$  and  $AH = EJ = x$ . Similarly, let  $JF = GC = y$  and  $JG = FC = z$ . Since  $ABCD$  is divided into four rectangles,  $AB$ ,  $HF$ , and  $DC$  are parallel and equal in length. Similarly,  $AD$ ,  $EG$ , and  $BC$  are parallel and equal in length. Thus,  $DG = HJ = w$ ,  $EB = JF = y$ ,  $BF = EJ = x$ , and  $HD = JG = z$ , as shown.

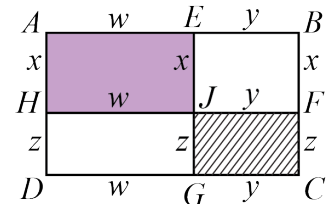

Since the perimeter of the shaded rectangle  $AEJH$  is 28 cm, it follows that  $2w + 2x = 28$  cm. Since the perimeter of the striped rectangle  $JFCG$  is 12 cm, it follows that  $2y + 2z = 12$  cm. The perimeter of  $ABCD$  is equal to  $2w + 2y + 2x + 2z$ . Rearranging, this gives  $2w + 2x + 2y + 2z$ . Since  $2w + 2x = 28$  cm and  $2y + 2z = 12$  cm, it follows that  $2w + 2x + 2y + 2z = 28 + 12 = 40$  cm. Therefore, the perimeter of rectangle  $ABCD$  is equal to 40 cm.

ANSWER: 40

12. First we notice that there are 9 integers in each row, and the largest integer in each row is a multiple of 9. Since  $2024 \div 9 \approx 224.89$ , the largest integer in the row above 2024 will be  $224 \times 9 = 2016$ . So the integers in the row with 2024 will be 2017, 2018, 2019, 2020, 2021, 2022, 2023, 2024, and 2025.

Since 9 is an odd number, the multiples of 9 alternate between even and odd. Similarly, Keoni's rows of integers alternate directions. When the largest integer in a row is odd, the integers in that row are written from left to right, and when the largest integer in a row is even, the integers in that row are written from right to left. Since 2025 is odd, the integers in this row will be written from left to right. We can then count backwards to determine the integer directly above 2024, as shown.

2016	2015	2014	2013	2012	2011	2010	2009	2008
2017	2018	2019	2020	2021	2022	2023	2024	2025

Thus, the integer directly above 2024 is 2009.

ANSWER: 2009

13. *Solution 1*

Since the remainder is 17 when 857 is divided by  $n$ , it follows that  $n$  divides  $857 - 17 = 840$ . That is,  $n$  is a factor of 840. The prime factorization of 840 is  $2 \times 2 \times 2 \times 3 \times 5 \times 7$ .

Since the remainder is 26 when 908 is divided by  $n$ , it follows that  $n$  divides  $908 - 26 = 882$ . That is,  $n$  is also a factor of 882. The prime factorization of 882 is  $2 \times 3 \times 3 \times 7 \times 7$ .



If  $n$  is a factor of both 840 and 882, then the prime factors of  $n$  must be common to both 840 and 882. Thus, the largest possible value of  $n$  has prime factorization  $2 \times 3 \times 7$ . Since  $2 \times 3 \times 7 = 42$ , the largest possible value of  $n$  is 42.

*Solution 2*

Since the remainder is 17 when 857 is divided by  $n$ , it follows that  $857 - 17 = 840$  is a multiple of  $n$ . Similarly, since the remainder is 26 when 908 is divided by  $n$ , it follows that  $908 - 26 = 882$  is a multiple of  $n$ .

Since 882 and 840 are both multiples of  $n$ , their difference,  $882 - 840 = 42$  must also be a multiple of  $n$ . Since we are looking for the largest possible value of  $n$ , let's check if  $n$  could equal 42. We notice that  $857 = 42 \times 20 + 17$  and  $908 = 42 \times 21 + 26$ . Thus, when 857 is divided by 42, the remainder is 17. Also, when 908 is divided by 42, the remainder is 26. Therefore the largest possible value of  $n$  is 42.

ANSWER: 42

14. Since  $WX = 12$  and  $WX$  is two-thirds of  $XZ$ , it follows that  $\frac{2}{3}$  of  $XZ$  is 12. Then  $\frac{1}{3}$  of  $XZ$  is 6. Since  $\frac{1}{3}$  of 18 is 6, it follows that  $XZ = 18$ .

Next, we will find the values of  $WY$  and  $YZ$ . Since  $WX = 12$  and  $XZ = 18$ , it follows that  $WZ = 12 + 18 = 30$ , so  $WY + YZ = 30$ . Since  $WY = 2 \times YZ$ , it follows that  $2 \times YZ + YZ = 30$ . Then  $3 \times YZ = 30$ , so  $YZ = 10$ . Then  $WY = 2 \times 10 = 20$ . Since  $WY = 20$  and  $WX = 12$ , it follows that  $XY = WY - WX = 20 - 12 = 8$ .

ANSWER: 8

15. The probability that the robot will reach the exit on the right side of the maze depends entirely on which opening it moves through when it sees 2 openings.

Notice that there are six squares in the maze where the robot must choose between two openings. These have been labelled with the letters  $A, B, C, D, E$ , and  $F$  as shown.

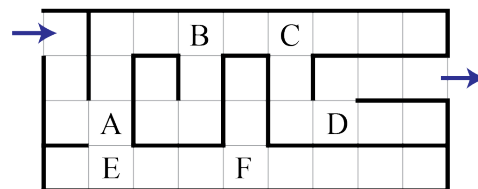

There is exactly one path that the robot can take to reach the exit. In order for the robot to follow this path, it must first turn left at  $A$  and then go straight at  $B$ . The probability of it doing each of these things independently is  $\frac{1}{2}$ . However, the probability that the robot turns left at  $A$  and then goes straight at  $B$  is  $\frac{1}{2}$  of  $\frac{1}{2}$ , which equals  $\frac{1}{4}$ .

The robot must then turn right at  $C$ . Independently, this has a probability of  $\frac{1}{2}$ , but remember that the probability that the robot gets to square  $C$  is  $\frac{1}{4}$ . So, the probability that the robot first turns left at  $A$ , then goes straight at  $B$ , and now turns right at  $C$  is  $\frac{1}{2}$  of  $\frac{1}{4}$ , which equals  $\frac{1}{8}$ .

Finally, the robot must turn left at  $D$ . Independently this has a probability of  $\frac{1}{2}$ , but the probability that the robot turns left at  $A$ , goes straight at  $B$ , turns right at  $C$ , and then turns left at  $D$  is  $\frac{1}{2}$  of  $\frac{1}{8}$ , which equals  $\frac{1}{16}$ .

ANSWER:  $\frac{1}{16}$



## Crossnumber Puzzle

	5	9	9		4	5	5	2
7	2		1	1	3			2
	2			5		6	6	0
2	5		6	6	7		4	
3		2	9		8	5		6
	2		1	5	9		3	1
2	6	4		1			8	
3			1	0	1		5	8
7	4	4	8		9	6	1	

## Across

1. The difference between  $\boxed{237}$  and  $\boxed{961}$  is  $961 - 237 = 724$ . If the number is halfway between  $\boxed{237}$  and  $\boxed{961}$ , it must be  $\frac{1}{2}$  of  $724 = 362$  more than 237 and 362 less than 961. The number is 599.
3. From the grid, the thousands digit is 4 and the ones digit is 2. Their product is  $4 \times 2 = 8$ . If the four digits multiply to 200, then the remaining digits must multiply to  $200 \div 8 = 25$ . The only two digits that multiply to 25 are 5 and 5. The number is 4552.
5. A dozen is a set of 12. So 6 dozen is  $6 \times 12 = 72$ .
6. The value is  $4 + \boxed{64} + 0.5 \times 90 = 4 + \boxed{64} + 45 = 113$ .



8. In 1 minute there are 60 seconds, and so it follows that in 11 minutes there are  $60 \times 11 = 660$  seconds.
10. From the grid, the tens digit is 2. If the difference is 3, then the ones digit is either  $2 + 3 = 5$  or  $2 - 3 = -1$ . However,  $-1$  is not a digit. Thus, the ones digit is 5 and the number is 25.
11. The area of the triangle is  $\frac{1}{2} \times \boxed{23} \times \boxed{58} = 667$ .
13. The number of days is  $\$87 \div \$3 = 29$ .
14. The ones digit must be a 5. From the grid, the tens digit is 8, thus the number is 85.
17. From the grid, the hundreds digit is 1 and the ones digit is 9. Since the mean equals the median, the mean must be an integer. Thus, the tens digit must be 2, 5, or 8. Both the mean and median of 1, 5, and 9 equal 5. Thus, the number is 159.
19. Since  $\boxed{159} \div 5 = 31.8$ , the number of positive integers less than  $\boxed{159}$  that are a multiple of 5 is 31.
20.  $\frac{2}{5}$  of  $\boxed{660} = \frac{2}{5} \times \boxed{660} = 264$ .
21. The smallest 3-digit prime number is 101.
23. There are only two two-digit numbers whose digits multiply to 40, namely 58 and 85. Any other number would have to have at least three digits, and therefore be larger than both of these two-digit numbers. Since  $58 < 85$ , the number is 58.
24. From the grid, the thousands digit is 7 and the ones digit is 8. Since the mode of the digits is 4, the other two digits must both be 4. Thus, the number is 7448.
25. The digits in  $\boxed{691}$  are 6, 9, and 1. When written in descending order, the number is 961.

## Down

1. From the grid the hundreds digit of this number is 2. It follows that the tens digit is 2. From the grid, the ones digit is 5. It follows that the thousands digit is 5. Thus, the number is 5225.
2. From the grid, the ones digit is 1. The only two-digit composite numbers with a ones digit of 1 are: 21, 51, 81, and 91. The only number from this list not divisible by 3 is 91.
3. The sum of the digits in  $\boxed{25}$  is  $2 + 5 = 7$ . From the grid, the ones digit of this number is 3. Since  $7 - 3 = 4$ , the tens digit must be 4 and the number is 43.
4. From the grid, the ones digit is 0. Since the mode of the digits is 2, the other two digits must both be 2. Thus, the number is 220.
7. In 1 year there are 12 months, and so it follows that in 13 years there are  $13 \times 12 = 156$  months.



9. From the grid, the tens digit of this number is 6. We know  $8 \times 8 = 64$ . In fact, the only two-digit number with a tens digit of 6 that is a product of two equal integers is 64.
10. Writing 2024 as a product of prime factors, we have  $2024 = 2 \times 2 \times 2 \times 11 \times 23$ . The largest prime number that is a factor of 2024 is 23.
11. From the grid, the hundreds digit is 6 and the tens digit is 9. The only three-digit number in this sequence with hundreds digit 6 and tens digit 9 is 691.
12. From the grid, the hundreds digit is 7. For this number to be the smallest possible number, the hundreds digit must be the smallest of the three digits. Since the three digits are consecutive integers, the number is 789.
15. From the grid, the ones digit is 1. Since this number is between  $\boxed{58}$  and  $\boxed{64}$  on the number line, the tens digit must be 6. The number is 61.
16. From the grid, the ones digit is 6. The only two-digit number with a ones digit of 6 that is a factor of  $\boxed{156}$  is 26.
18. From the grid, the hundreds digit is 5 and the ones digit is 0. Trying values for the tens digit, if the tens digit is 1 then  $510 \div (5 + 1 + 0) = 510 \div 6 = 85$ . This is the only possible value for the tens digit. The number is 510.
19. The thousands digit must be 3. From the grid, the tens digit is 5 and the ones digit is 1. In order to be greater than 3785 and is less than 3915, the hundreds digit must be 8. The number is 3851.
20. The perimeter is equal to  $3 \times 79 = 237$ .
21. From the grid, the tens digit is 1. Thus, the ones digit is  $9 - 1 = 8$ . The number is 18.
22. A rectangle with area 95 and width 5 has length  $95 \div 5 = 19$ .



### Logic Puzzle

We start by considering clues (4) and (8):

- (4) Allie sat in seat A6.
- (8) Dita had chips and sat next to Allie.

From these clues, we can determine that Dita sat in seat A7.

Next we consider clues (6) and (7):

- (6) Five of the friends are Edison, Dita, Katja, Neeraj, and Vasilije. The other three friends are the person with the nachos, the person in seat A15, and the person with the pretzel.
- (7) The friends with the nachos and the licorice sat together, and were not in the front row.

Since Allie's name is not mentioned in clue (6), it follows that she is either the person with the nachos, the person in seat A15, or the person with the pretzel. Since we know she is in seat A6, she cannot be the person in seat A15. From clue (7), we know the person with the nachos did not sit in the front row. Since Allie sat in the front row, it follows that she cannot be the person with the nachos, so she must be the person with the pretzel.

The following partially-completed seating chart contains the information we know so far.

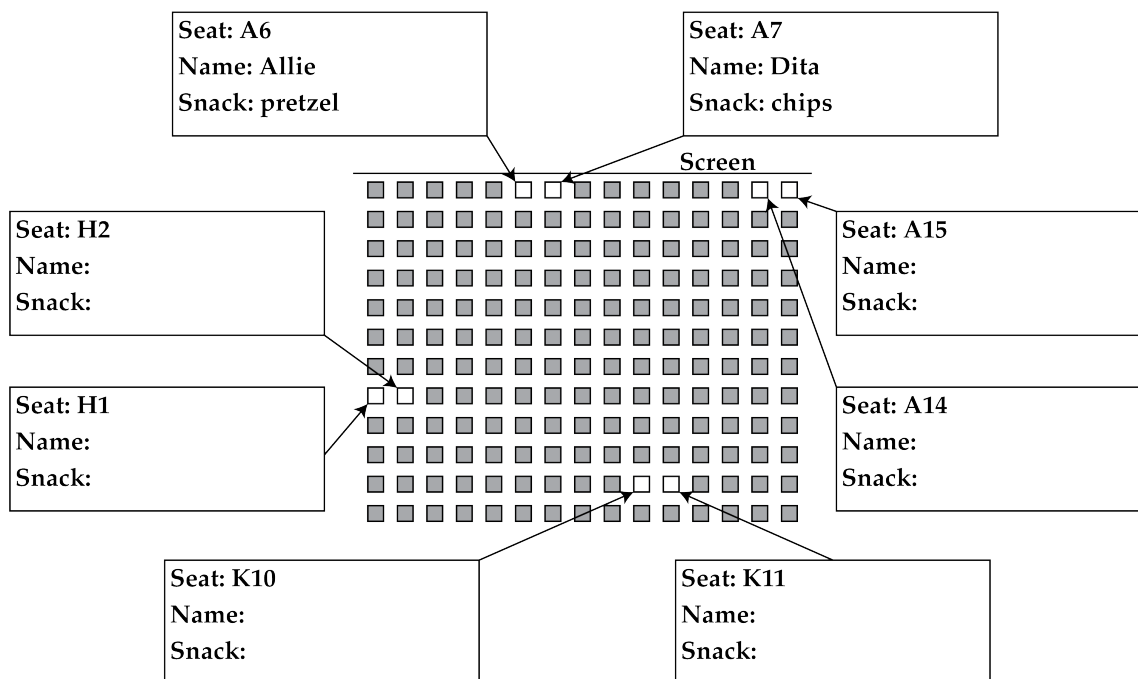

Next we consider clues (2), (5), and (6):

- (2) The person with the chocolate bar sat in an aisle seat (i.e. the first or last seat in a row) and did not sit next to the person with the hot dog or the person with the popcorn.
- (5) Katja sat in an aisle seat next to her friend who had popcorn.
- (6) Five of the friends are Edison, Dita, Katja, Neeraj, and Vasilije. The other three friends are the person with the nachos, the person in seat A15, and the person with the pretzel.



Since Katja's name is mentioned in clue (6), it follows that she is not the person in seat A15. Since we know she sat in an aisle seat, it follows that she sat in seat H1. Then from clue (5), we determine that the person who sat in seat H2 had popcorn.

From clue (2), we can determine that the person with the chocolate bar sat in seat A15, since it is the only remaining aisle seat that is not next to the person with the popcorn.

Next we consider clue (7):

- (7) The friends with the nachos and the licorice sat together, and were not in the front row.

Since seats K10 and K11 are the only remaining pair of seats whose snacks are unknown, it follows that the people who sat in seats K10 and K11 had nachos and licorice, in some order.

The following partially-completed seating chart contains the information we know so far.

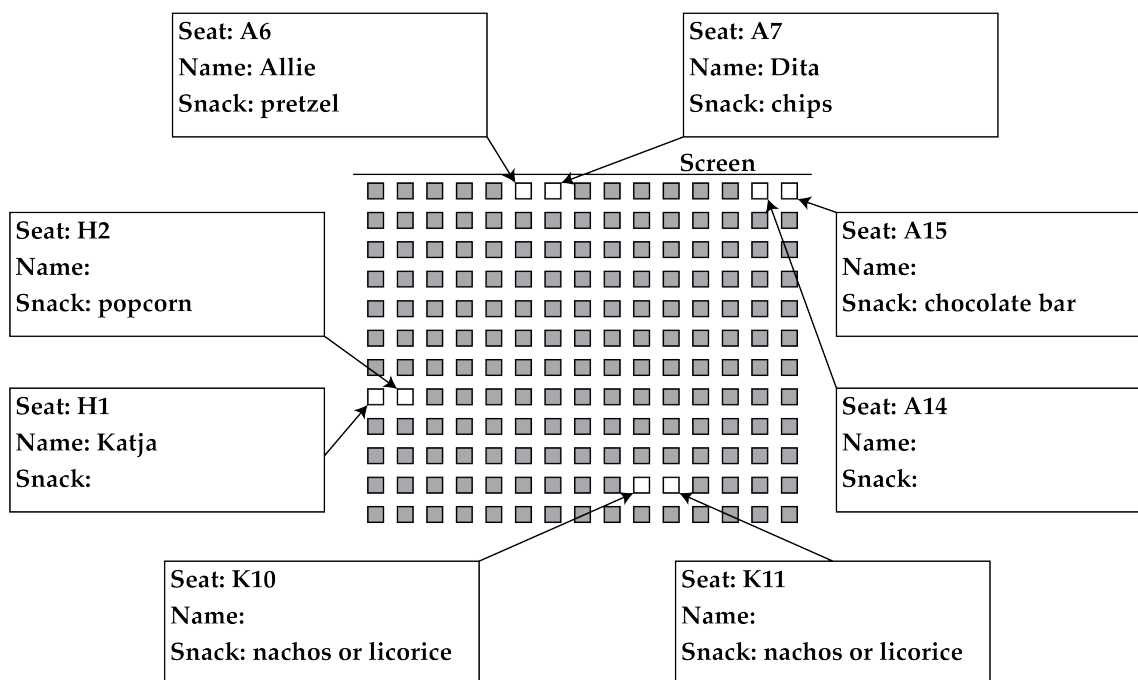

Next we consider clues (1), (3), and (6):

- (1) Carlo sat next to Edison, who had gummy bears.
- (3) Yun sat in an even-numbered seat next to Vasilije.
- (6) Five of the friends are Edison, Dita, Katja, Neeraj, and Vasilije. The other three friends are the person with the nachos, the person in seat A15, and the person with the pretzel.

Since Carlo's name is not mentioned in clue (6), it follows that he is either the person with the nachos, the person in seat A15, or the person with the pretzel. Since we know that the person with the nachos sat next to the person with the licorice, and from clue (1) Carlo sat next to the person with the gummy bears, it follows that Carlo cannot be the person with the nachos. Carlo also cannot be the person with the pretzel, because we know that Allie was the person with the pretzel. It follows that Carlo must be the person in seat A15. Then Edison sat in seat A14.





From clue (3), we can conclude that Yun sat in seat K10 and Vasilije sat in seat K11, since they are the only remaining pair of seats without names.

Since Vasilije's name is mentioned in clue (6), it follows that he is not the person with the nachos. Then Yun must have had the nachos and Vasilije must have had the licorice.

Now we notice that all the names have been filled in except for the person in seat H2. From clue (6), we have not used the name Neeraj. We can conclude that Neeraj sat in seat H2.

Finally we consider clue (2):

- (2) The person with the chocolate bar sat in an aisle seat (i.e. the first or last seat in a row) and did not sit next to the person with the hot dog or the person with the popcorn.

The only remaining piece of information to fill in is the snack for the person in seat H1. From clue (2), we know that someone had a hot dog, however we have not assigned it to anyone. We can conclude that Katja in seat H1 had the hot dog, and confirm that she did not sit next to the person with the chocolate bar.

This completes the logic puzzle.

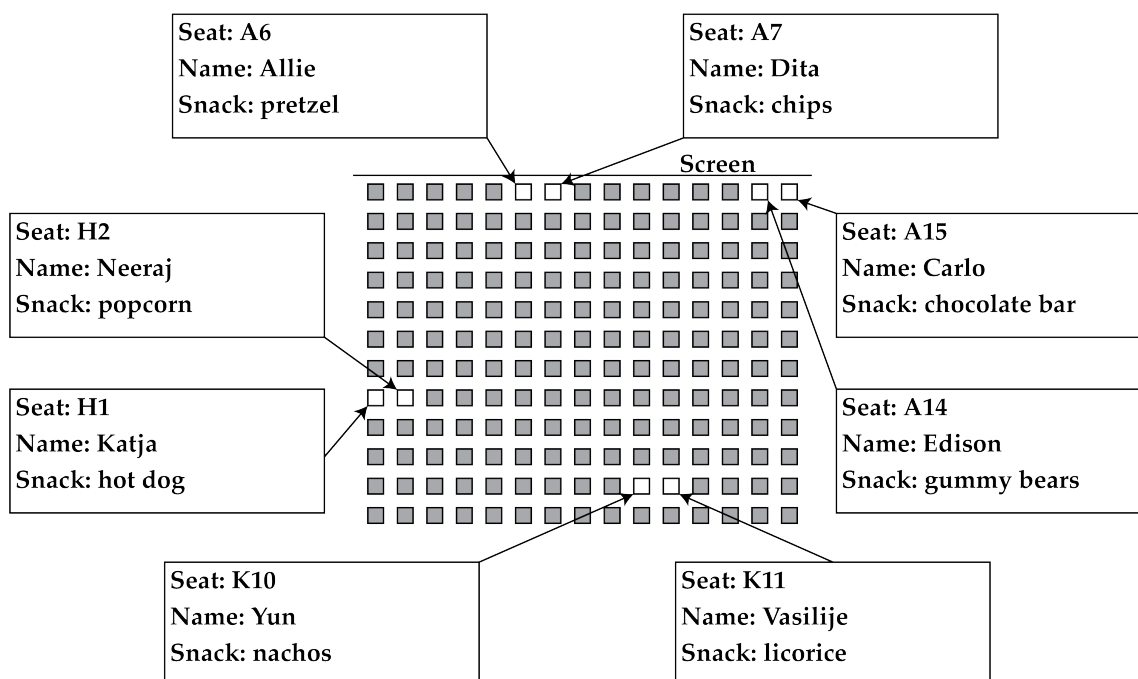



## Relay

(Note: Where possible, the solutions are written as if the value of  $N$  is not initially known, and then  $N$  is substituted at the end.)

### Practice Relay

P1:  $x + 10 = 1 + 10 = 11$ .

P2: Sebastian made  $5 + 4 + N = 9 + N$  bracelets in total.

Since the answer to the previous question is 11, then  $N = 11$ , and so Sebastian made  $9 + 11 = 20$  bracelets.

P3: There are 3 plain umbrellas and 2 spotted umbrellas. So the total cost of the umbrellas is  $\$10 \times 3 + \$N \times 2 = \$30 + \$N \times 2$ .

Since the answer to the previous question is 20, then  $N = 20$ , and so the total cost of the umbrellas is  $\$30 + \$20 \times 2 = \$30 + \$40 = \$70$ .

P4: If Kiran will be 11 years old in 6 years, then Kiran must be  $11 - 6 = 5$  years old today.

Then in  $N$  years, Kiran will be  $5 + N$  years old.

Since the answer to the previous question is 70, then  $N = 70$ , and so Kiran will be  $5 + 70 = 75$  years old.







ANSWER: 11, 20, 70, 75

### Relay A

P1: Since we are looking for the number of students with at least one sibling, we add up the bars for 1, 2, 3, and 4 siblings. This gives a total of  $12 + 9 + 4 + 1 = 26$  students.

P2: In total, Safiya ran for 50 minutes. Of these,  $50 - N$  minutes were spent running alone.

Since the answer to the previous question is 26, then  $N = 26$ , and so she ran alone for  $50 - 26 = 24$  minutes.

P3: If we remove the same shape from each side of the scale, it will remain balanced. So, removing one  and one  from each side leaves two  and one  on the left side, and one  on the right side. Thus, the mass of one  is equal to  $N + N + \frac{N}{2} = \frac{5N}{2}$  g.

Since the answer to the previous question is 24, then  $N = 24$ , and so the mass of one  is  $\frac{5 \times 24}{2} = 60$  g.

P4: The area of the shaded rectangle is  $(20 \times N)$  m<sup>2</sup>. The area of the white rectangle is  $10 \times 30 = 300$  m<sup>2</sup>. Thus, the area of the shaded region is  $(20 \times N - 300)$  m<sup>2</sup>.

Since the answer to the previous question is 60, then  $N = 60$ , and so the area of the shaded region is  $20 \times 60 - 300 = 1200 - 300 = 900$  m<sup>2</sup>.

ANSWER: 26, 24, 60, 900

Relay B

- P1: We are looking for a positive integer that is divisible by both 4 and 6, and is also less than 20. The only such integer is 12.
- P2: Of the five numbers we know, only 3 of them (namely 99, 57, and 30) are divisible by 3. Since the answer to the previous question is 12, then  $N = 12$ , which is divisible by 3. Thus, there are 4 numbers that are divisible by 3.
- P3: Written in order from smallest to largest, the first four fractions are  $\frac{1}{5}$ ,  $\frac{2}{5}$ ,  $\frac{1}{2}$ ,  $\frac{3}{4}$ . The sum of the two smallest fractions is  $\frac{1}{5} + \frac{2}{5} = \frac{3}{5}$ . Since the answer to the previous question is 4, then  $N = 4$ . Since  $\frac{1}{4} < \frac{1}{2}$ , the sum of the three smallest fractions is  $\frac{3}{5} + \frac{1}{4} = \frac{12}{20} + \frac{5}{20} = \frac{17}{20}$ .
- P4: If the input number is 7, then after Step 1 the result will be  $7 \times 7 = 49$ . Since 49 is odd, after Step 2 the result will be  $49 + 5 = 54$ . After Step 3 the result will be  $54 \div 2 = 27$ . After Step 4 the result will be  $27 - 7 = 20$ . After Step 5 the result will be  $20 \times N$ . Since the answer to the previous question is  $\frac{17}{20}$ , then  $N = \frac{17}{20}$ , and so the output is  $20 \times \frac{17}{20} = 17$ .

ANSWER: 12, 4,  $\frac{17}{20}$ , 17Relay C

- P1: In numeric form, the number is 2564014. The sum of its digits is then  $2 + 5 + 6 + 4 + 0 + 1 + 4 = 22$ .
- P2: If the probability of choosing a yellow marble at random is 50%, then half, or  $\frac{N}{2}$ , of the marbles are yellow. It follows that  $\frac{N}{2}$  marbles are blue or red. Since 5 marbles are blue, then  $\frac{N}{2} - 5$  marbles are red. Since the answer to the previous question is 22, then  $N = 22$ , and so  $\frac{22}{2} - 5 = 11 - 5 = 6$  marbles are red.
- P3: The 4<sup>th</sup> term is equal to the sum of the 2<sup>nd</sup> and 3<sup>rd</sup> terms, which is  $3 + 7 = 10$ . In this way, the 5<sup>th</sup> term is equal to  $7 + 10 = 17$ , the 6<sup>th</sup> term is equal to  $10 + 17 = 27$ , and the 7<sup>th</sup> term is equal to  $17 + 27 = 44$ . Since the answer to the previous question is 6, then  $N = 6$ , and so we are looking for the 6<sup>th</sup> term, which is 27.
- P4: The cost of 2 hamburgers is  $\$1.75 \times 2 = \$3.50$ . The cost of 3 hot dogs is  $\$1.25 \times 3 = \$3.75$ . The cost of 2 boxes of fries is  $\$1.50 \times 2 = \$3.00$ . The cost of 2 drinks is  $\$0.75 \times 2 = \$1.50$ . Thus, the total cost of the food is  $\$3.50 + \$3.75 + \$3.00 + \$1.50 = \$11.75$ . The amount of cash Jacob has left will then be  $\$N - \$11.75$ . Since the answer to the previous question is 27, then  $N = 27$ , and so  $\$27 - \$11.75 = \$15.25$  is left.

ANSWER: 22, 6, 27, 15.25