



Problem of the Month

Solution to Problem 2: November 2023

- (a) (i) Because a circle has so much symmetry, there are many squares whose four vertices all lie on the circle. For example, the points $(1, 0)$, $(0, 1)$, $(-1, 0)$, and $(0, -1)$ are the vertices of a square and all lie on the circle with equation $x^2 + y^2 = 1$. As well, the four points $\left(\frac{1}{\sqrt{2}}, \frac{1}{\sqrt{2}}\right)$, $\left(-\frac{1}{\sqrt{2}}, \frac{1}{\sqrt{2}}\right)$, $\left(-\frac{1}{\sqrt{2}}, -\frac{1}{\sqrt{2}}\right)$, and $\left(\frac{1}{\sqrt{2}}, -\frac{1}{\sqrt{2}}\right)$ are the vertices of a square and all lie on the circle.

Note: In general, if we start with a point P and rotate P repeatedly by 90° counterclockwise about the origin, the four points obtained are always the vertices of a square. Starting with the point with coordinates (a, b) , the coordinates of the point obtained by a rotation of 90° counterclockwise about the origin are $(-b, a)$. If we rotate 90° counterclockwise two more times, we get the points with coordinates $(-a, -b)$ and $(b, -a)$. Thus, for any real numbers a and b , the points with coordinates (a, b) , $(-b, a)$, $(-a, -b)$, and $(b, -a)$ are the vertices of a square. This will be useful in later parts. In addition, if (a, b) is a point on the circle with equation $x^2 + y^2 = 1$, then $a^2 + b^2 = 1$. Then since $(\pm a)^2 + (\pm b)^2 = a^2 + b^2 = 1$, the four points (a, b) , $(-b, a)$, $(-a, -b)$, and $(b, -a)$, which are the vertices of a square, all lie on the circle.

- (ii) Observe that the four points $(a, 0)$, $(0, b)$, $(-a, 0)$, and $(0, -b)$ are on the ellipse with equation $\frac{x^2}{a^2} + \frac{y^2}{b^2} = 1$, as shown in the illustration below.

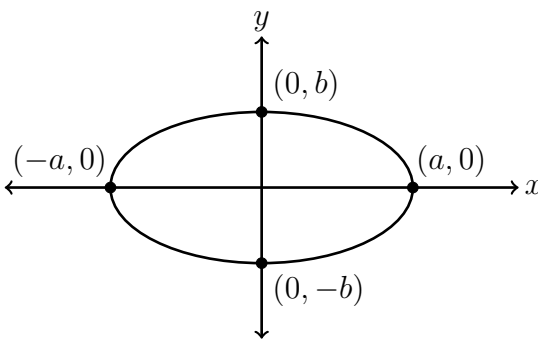

Because $x^2 = (-x)^2$ and $y^2 = (-y)^2$, if (s, t) is a point on the ellipse, then $(s, -t)$ and $(-s, t)$ are both on the ellipse. Therefore, the ellipse has reflective symmetry in the x -axis and the y -axis, which is also evident from the diagram. It is reasonable to expect there to be a square inscribed in the ellipse that also has reflective symmetry in the two axes. The vertices of such a square should be of the form (t, t) , $(-t, t)$, $(-t, -t)$, and $(t, -t)$ for some real number $t \neq 0$.

Notice that the point (t, t) is on the line with equation $y = x$, so assuming such a square exists, we should be able to find one of its vertices by solving the system of

equations

$$y = x$$
$$\frac{x^2}{a^2} + \frac{y^2}{b^2} = 1.$$

Substituting the first equation into the second and finding a common denominator gives

$$\frac{b^2x^2 + a^2x^2}{a^2b^2} = 1$$

which rearranges to give

$$x^2 = \frac{a^2b^2}{a^2 + b^2}.$$

Since a and b are positive, $\sqrt{a^2b^2} = ab$, and so we get that $x = \frac{ab}{\sqrt{a^2 + b^2}}$. We therefore expect that the four points

$$\left(\frac{ab}{\sqrt{a^2 + b^2}}, \frac{ab}{\sqrt{a^2 + b^2}} \right), \left(-\frac{ab}{\sqrt{a^2 + b^2}}, \frac{ab}{\sqrt{a^2 + b^2}} \right)$$
$$\left(-\frac{ab}{\sqrt{a^2 + b^2}}, -\frac{ab}{\sqrt{a^2 + b^2}} \right), \left(\frac{ab}{\sqrt{a^2 + b^2}}, -\frac{ab}{\sqrt{a^2 + b^2}} \right)$$

are all on the ellipse and are the vertices of a square. As discussed in the solution to part (i), these points are of the form (t, t) , $(-t, t)$, $(-t, -t)$, and $(t, -t)$, so they are the vertices of a square. It is an exercise to verify that they are all on the ellipse.

Below is a picture of the ellipse with a square inscribed.

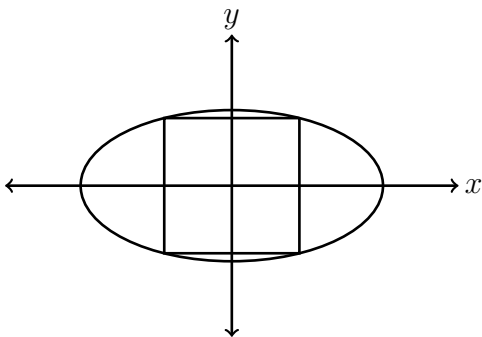

Follow up question: If $a = b$, then the ellipse is a circle and there are infinitely many inscribed squares. If $a \neq b$, is the square in the solution above the only square inscribed in the ellipse?

(iii) In this case, the loop is the regular hexagon pictured below.

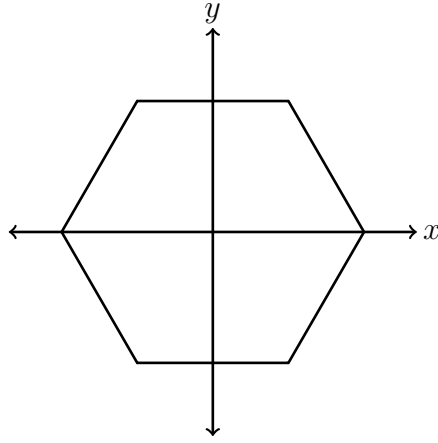

Similar to the situation in part (ii), the loop has reflective symmetry in both the x and y axes. Thus, we might again guess that there is an inscribed square with reflective symmetry in both axes. If such a square exists, then one of the vertices will have the form (t, t) . Thus, we are looking for the points (there are two of them) where the line with equation $y = x$ intersects the hexagon.

The line with equation $y = x$ must intersect the part of the hexagon that is in the first quadrant. Notice that $(\frac{1}{2}, \frac{\sqrt{3}}{2})$ is above the line with equation $y = x$, so the horizontal line segment in the first quadrant will not intersect the line with equation $y = x$. Therefore, the intersection point we seek is on the line segment joining $(1, 0)$ to $(\frac{1}{2}, \frac{\sqrt{3}}{2})$, which has equation $y = -\sqrt{3}x + \sqrt{3}$. To find the point of intersection, we set $x = -\sqrt{3}x + \sqrt{3}$ and solve to get $x = \frac{\sqrt{3}}{1+\sqrt{3}}$. Recall that we hope the square has vertices at (t, t) , $(-t, t)$, $(-t, -t)$, and $(t, -t)$. You can check that with $t = \frac{\sqrt{3}}{1+\sqrt{3}}$, these four points lie on the given hexagon. Below is a picture of the hexagon with the inscribed square.

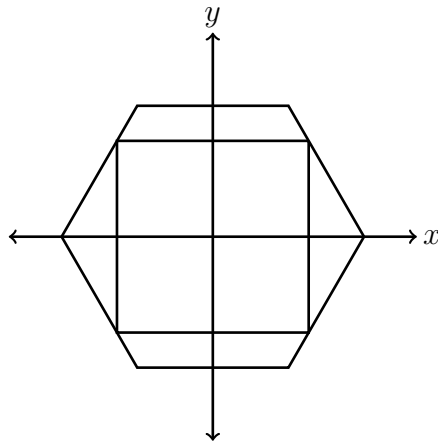

Follow up question: There are two other squares inscribed in the hexagon. They arise from rotating the square in the solution by 60° clockwise or 60° counterclockwise about the origin. Are these the only possible squares?

- (iv) The graphs of the relations $y = -\frac{1}{2}x^2 + \frac{1}{6}x + \frac{16}{9}$ and $y = x$ are pictured on the same axes below. The loop, which is the boundary of the region enclosed by the two graphs, is bold.

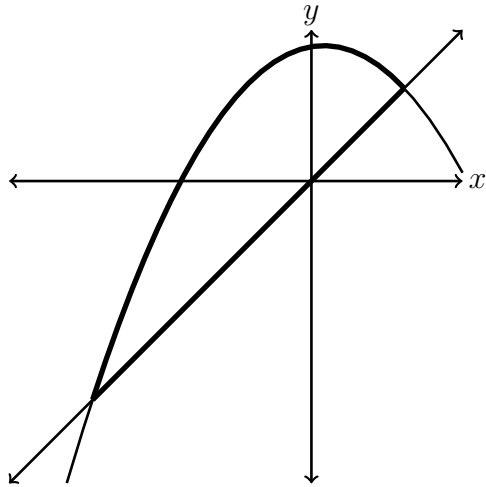

One approach is to try to find a square with two adjacent vertices on the line with equation $y = x$ and the other two vertices on the parabola. Why should we expect such a square even exists? Imagine drawing a line L that is parallel to the line with equation $y = x$, lies above the line with equation $y = x$, and intersects the parabola twice. By drawing lines with slope -1 through these two points of intersection, we get a rectangle with two vertices on the parabola and two vertices on the line. The diagrams below show such configurations with the rectangle shaded in each case.

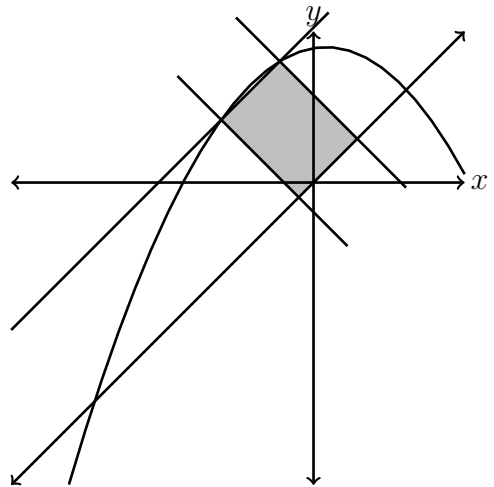
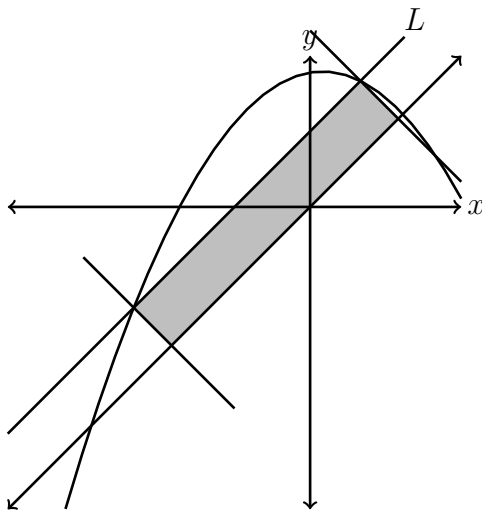

If the points of intersection of L with the parabola are far apart, as in the left diagram, then the two sides of the rectangle that are parallel to the line $y = x$ are longer than the other two sides. If the points of intersection are close together, as in the right diagram, then the two sides of the rectangle that are parallel to the line $y = x$ are shorter than the other two sides. It seems reasonable to guess that somewhere in between those two extremes is a happy medium where the rectangle is a square. Formally, this kind of argument is an application of something called the *Intermediate Value Theorem*.

Let's use this thinking to find the coordinates of such a square. Let L be the line with equation $y = x + b$ where b is the positive real number that will cause the rectangle to be a square. The vertices of the square we hope for are the points of intersection

of L with the parabola. To find these points, we set $x + b$ equal to $-\frac{1}{2}x^2 + \frac{1}{6}x + \frac{16}{9}$ and rearrange to get.

$$\begin{aligned}x + b &= -\frac{1}{2}x^2 + \frac{1}{6}x + \frac{16}{9} \\0 &= \frac{1}{2}x^2 + \frac{5}{6}x + b - \frac{16}{9} \\0 &= 9x^2 + 15x + (18b - 32)\end{aligned}$$

where the last line is obtained by multiplying the second-last line by 18.

We can now use the quadratic formula to get

$$\begin{aligned}x &= \frac{-15 \pm \sqrt{15^2 - 4(9)(18b - 32)}}{18} \\&= \frac{-5 \pm \sqrt{5^2 - 4(18b - 32)}}{6} \\&= \frac{-5 \pm 3\sqrt{17 - 8b}}{6}\end{aligned}$$

Note: Since we are assuming that the line $y = x + b$ has two points of intersection with the parabola, this quadratic equation must have two distinct real solutions. This means we must have $17 - 8b > 0$ and so $b < \frac{17}{8}$. Revisiting the diagrams, it should be clear that there is an upper bound on the values of b that can result in the line intersecting the parabola. The diagrams also indicate that $b > 0$.

Therefore, the x -coordinates of the points of intersection are $\frac{-5 - 3\sqrt{17 - 8b}}{6}$ and $\frac{-5 + 3\sqrt{17 - 8b}}{6}$.

The difference between the x -coordinates of these points is

$$\frac{-5 + 3\sqrt{17 - 8b}}{6} - \frac{-5 - 3\sqrt{17 - 8b}}{6} = \sqrt{17 - 8b}$$

and since the points are on a line of slope 1, the distance between the y -coordinates is also $\sqrt{17 - 8b}$. Therefore, the distance between the two points is

$$\begin{aligned}\sqrt{\left(\sqrt{17 - 8b}\right)^2 + \left(\sqrt{17 - 8b}\right)^2} &= \sqrt{2(17 - 8b)} \\&= \sqrt{34 - 16b}\end{aligned}$$

We will leave it as an exercise to show that the perpendicular distance between L and the line with equation $y = x$ is equal to $\frac{b}{\sqrt{2}}$. This means our square has sides of length $\sqrt{34 - 16b}$ and $\frac{b}{\sqrt{2}}$. A square has four equal sides, so this implies the equation $\sqrt{34 - 16b} = \frac{b}{\sqrt{2}}$. Squaring both sides, we have $34 - 16b = \frac{b^2}{2}$ which can

be rearranged to get $b^2 + 32b - 68 = 0$. Factoring gives $(b - 2)(b + 34) = 0$, so the possible values of b are 2 and -34 .

Since we need b to be positive, we conclude that $b = 2$, so the line L has equation $y = x + 2$. The x -coordinates of the points of intersection of L with the parabola were computed earlier. Substituting $b = 2$ into these expressions, we get x -coordinates of $\frac{-5 - 3\sqrt{17 - 8b}}{6} = -\frac{4}{3}$ and $\frac{-5 + 3\sqrt{17 - 8b}}{6} = -\frac{1}{3}$. These points lie on the line with equation $y = x + 2$, so the coordinates of two of the vertices of the square are $(-\frac{4}{3}, \frac{2}{3})$ and $(-\frac{1}{3}, \frac{5}{3})$.

To find the other two vertices, we can find the equations of the lines of slope -1 through each of these points, then find their intersection points with the line with equation $y = x$. We will not include the calculations here, but the resulting points are $(-\frac{1}{3}, -\frac{1}{3})$ and $(\frac{2}{3}, \frac{2}{3})$.

Indeed, it is not difficult to check that the points

$$\left(-\frac{4}{3}, \frac{2}{3}\right), \left(-\frac{1}{3}, -\frac{1}{3}\right), \left(\frac{2}{3}, \frac{2}{3}\right), \left(-\frac{1}{3}, \frac{5}{3}\right)$$

are the vertices of a square. Below is a plot of the loop along with the square with these four points as its vertices.

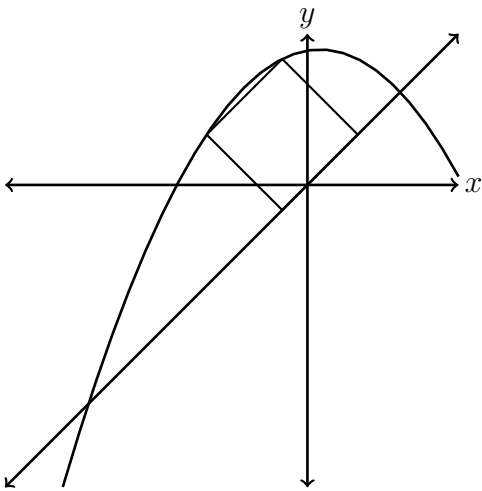

(v) The two parabolas are pictured below. The loop is bold.

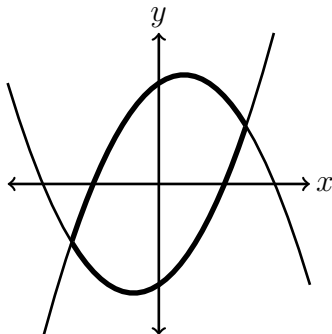

By the discussion at the end of the solution to part (i), the four points

$$\left(1, \frac{1}{3}\right), \left(-\frac{1}{3}, 1\right), \left(-1, -\frac{1}{3}\right), \left(\frac{1}{3}, -1\right).$$

are the vertices of a square. Furthermore, you can check that these four points all lie on the loop.

For the rest of the solution to this part, we will show how one might find these four points. The task is a bit trickier here because, unlike in earlier parts, it is not easy to guess what the slope of the sides of the square should be. However, there is still some symmetry that we can use. Specifically, the loop has 180° rotational symmetry about the origin because the two parabolas are each the result of rotating the other 180° about the origin. This is not difficult to believe from the diagram, but it can also be verified algebraically.

This symmetry suggests two things. The first is that we should look for a square that has 180° rotational symmetry about the origin. The second is that each of the two parabolas should contain two vertices of the square.

A square that has 180° rotational symmetry about the origin must also have 90° rotational symmetry about the origin (you might want to take some time to convince yourself of this). Again by the discussion from part (i), the vertices of the square should be at the points with coordinates (a, b) , $(-b, a)$, $(-a, -b)$, and $(b, -a)$ where a and b are some real numbers.

The parabola with equation $y = x^2 + \frac{2}{3}x - \frac{4}{3}$ should contain two vertices of the square with the property that one of these vertices is the result of rotating the other vertex 90° about the origin. Thus, for some a and b , this parabola should contain the points (a, b) and $(-b, a)$. This implies the following two equations in a and b :

$$\begin{aligned} b &= a^2 + \frac{2}{3}a - \frac{4}{3} \\ a &= (-b)^2 + \frac{2}{3}(-b) - \frac{4}{3} \end{aligned}$$

The second equation gives an expression for a in terms of b , so we can substitute this expression into the first equation and simplify as follows:

$$\begin{aligned} b &= \left((-b)^2 + \frac{2}{3}(-b) - \frac{4}{3}\right)^2 + \frac{2}{3}\left((-b)^2 + \frac{2}{3}(-b) - \frac{4}{3}\right) - \frac{4}{3} \\ &= \left(b^2 - \frac{2}{3}b - \frac{4}{3}\right)^2 + \frac{2}{3}\left(b^2 - \frac{2}{3}b - \frac{4}{3}\right) - \frac{4}{3} \\ 9b &= (3b^2 - 2b - 4)^2 + 2(3b^2 - 2b - 4) - 12 && \text{(multiply by 9)} \\ 9b &= 9b^4 - 12b^3 - 14b^2 + 12b - 4 \\ 0 &= 9b^4 - 12b^3 - 14b^2 + 3b - 4 \end{aligned}$$

In general, we should not expect to easily find a closed expression for the root of a quartic polynomial. However, this question was designed to work out nicely. After some checking, you might notice that $b = -1$ is a root of this equation. Indeed, $9(-1)^4 - 12(-1)^3 - 14(-1)^2 + 3(-1) - 4 = 0$. We could factor to get

$$0 = (b + 1)(9b^3 - 21b^2 + 7b - 4)$$

but $b = -1$ is the value we seek, so the other roots of the quartic are not of any use in this solution (though you might want to think about whether they have any “geometric” meaning). With $b = -1$, the equation $a = (-b)^2 + \frac{2}{3}(-b) - \frac{4}{3}$ implies $a = \frac{1}{3}$, so one of the points is $(-b, a) = (1, \frac{1}{3})$. This is the first of the four points listed at the start of the solution to this part. Rotating the point $(1, \frac{1}{3})$ by 90° , 180° , and 270° about the origin gives the other three points. You can check that each of the two parabolas contains two of these points. Below is a diagram of the loop with the square included.

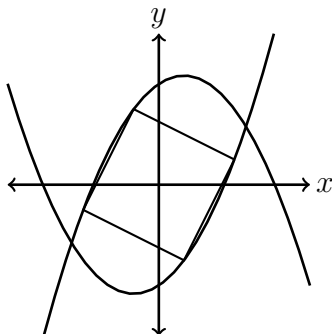

- (b) Given $\triangle ABC$, there exists $\triangle DEF$ so that $\triangle ABC$ is similar to $\triangle DEF$ and DE is horizontal with length 1. So we proceed by examining such a triangle $\triangle DEF$ with vertices $D(0,0)$, $E(1,0)$, and $F(a,b)$ where $a > 0$ and $b > 0$. Moreover, if $\triangle ABC$ is acute, then so is $\triangle DEF$ and we must have $0 < a < 1$.

We will show that there is a unique square whose vertices are on the perimeter of $\triangle DEF$ with two of its vertices are on DE . To find such a square, we will assume there is such a square, deduce conditions on the location of the vertices of such a square, and then confirm that the four points we find actually satisfy the given conditions.

Suppose W, X, Y, Z are the vertices of the square, with W and X on DE . The diagram below shows what this picture should look like.

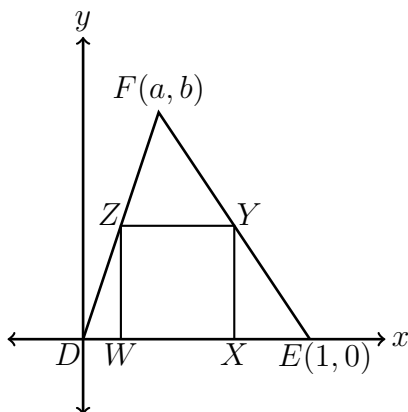

The equations of the lines joining $(0,0)$ to (a,b) and $(1,0)$ to (a,b) are $y = \frac{b}{a}x$ and $y = \frac{b}{a-1}(x-1)$ respectively.

The coordinates of W , X , Y , and Z must then take the form

$$\begin{aligned} W &= (s, 0) \\ X &= (t, 0) \\ Y &= \left(t, \frac{b}{a-1}(t-1) \right) \\ Z &= \left(s, \frac{b}{a} \right) \end{aligned}$$

for some s and t with $0 < s < t < 1$. Since we want these to be the vertices of a square, we have the following pair of simultaneous equations:

$$\begin{aligned} \frac{b}{a}s &= \frac{b}{a-1}(t-1) \\ t - s &= \frac{b}{a}. \end{aligned}$$

The first equation comes from insisting that the line joining Y to Z is horizontal, and the second comes from insisting that the width of the resulting rectangle is equal to its height. Rearranging the second equation gives $t = \left(\frac{b}{a} + 1\right)s$ and substituting this into the first equation gives

$$\frac{b}{a}s = \frac{b}{a-1} \left(\left(\frac{b}{a} + 1 \right) s - 1 \right).$$

Solving for s gives

$$s = \frac{a}{b+1}$$

and therefore

$$t = \frac{b+a}{b+1}.$$

Therefore, if such a square exists, it must have vertices

$$\begin{aligned} W &= \left(\frac{a}{b+1}, 0 \right) \\ X &= \left(\frac{b+a}{b+1}, 0 \right) \\ Y &= \left(\frac{b+a}{b+1}, \frac{b}{b+1} \right) \\ Z &= \left(\frac{a}{b+1}, \frac{b}{b+1} \right). \end{aligned}$$

We leave it as an exercise to show that these four vertices indeed are the vertices of a square and that they are all on the perimeter of the triangle. Since the assumption that they were the vertices of a square led to specific coordinates of the four points, we can also conclude that there is exactly one square with vertices on $\triangle DEF$ so that two of them are on DE .

By the argument above, in $\triangle DEF$, there is always exactly one square with two vertices on DE and one vertex on each of DF and EF . In $\triangle ABC$, this corresponds to exactly

one square with two vertices on AB and one on each of AC and BC . Since there are three sides in $\triangle ABC$, there are exactly three squares.

Note that if $\triangle ABC$ is obtuse, then the preceding arguments can be modified to show that there is exactly one square with vertices on the perimeter of $\triangle ABC$. Two of the vertices will always be on the longest side. What do you think happens in a right-angled triangle?