



UNIVERSITY OF  
**WATERLOO**



The CENTRE for EDUCATION in  
MATHEMATICS and COMPUTING



2022  
*Beaver  
Computing  
Challenge  
(Grades 7 & 8)*

*Questions*

# Part A

# Pick Up Sticks

## Story

Ana drops six sticks on a table as shown.

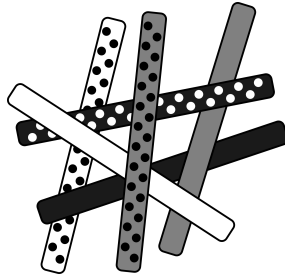

Then she picks all the sticks up according to the following rules:

1. Pick up one stick at a time.
2. Only pick up a stick if no other stick is on top of it.

## Question

In which order did Ana pick up the sticks?

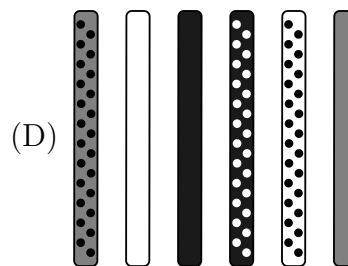
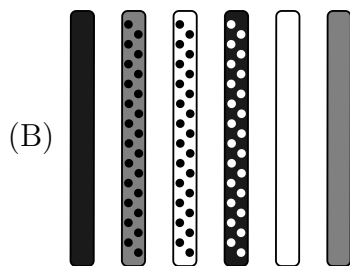
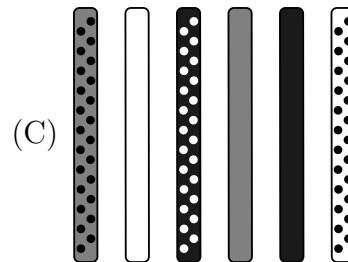
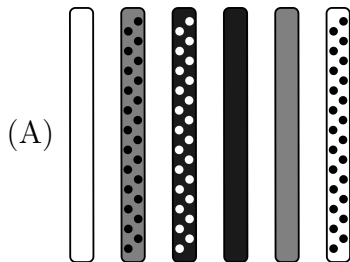

# Missing Library Book

## Story

Bibako has left a book somewhere in their house. The picture below is a map of the house. They begin searching for the book in the room marked START. Each of the other rooms is marked with a picture.

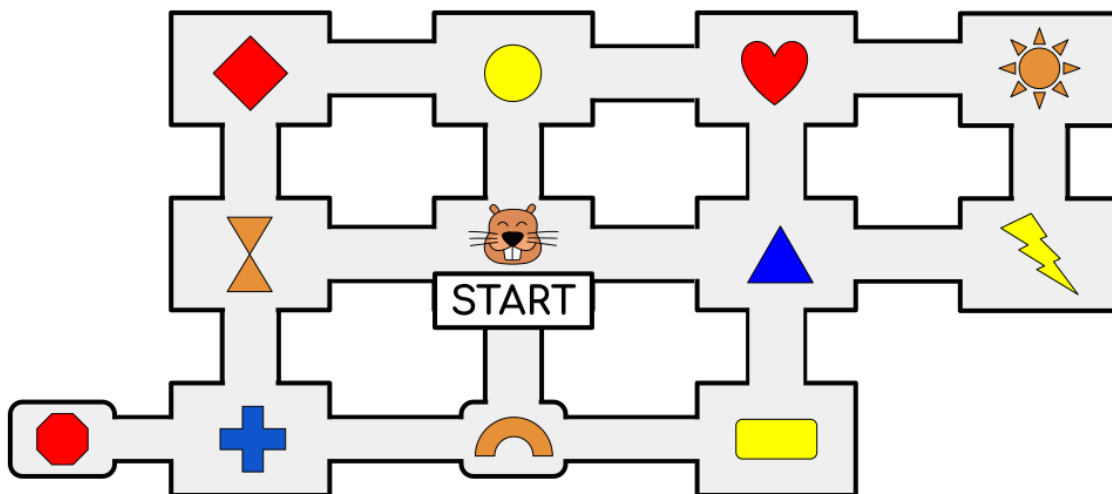

Bibako moves around the house from room to room until they find the book. Their movements, in order, are represented by the sequence of arrows below. Each arrow represents a move from Bibako's current location to an adjacent room indicated by the direction of the arrow.

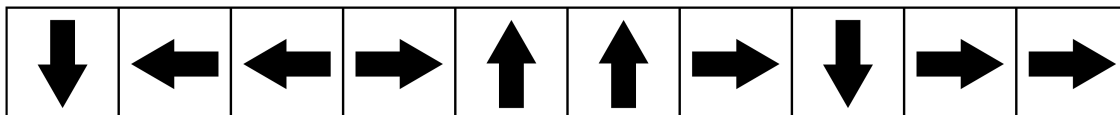

## Question

Which picture corresponds to the room where the book is found?

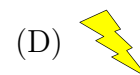
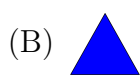

## Secret Message

### Story

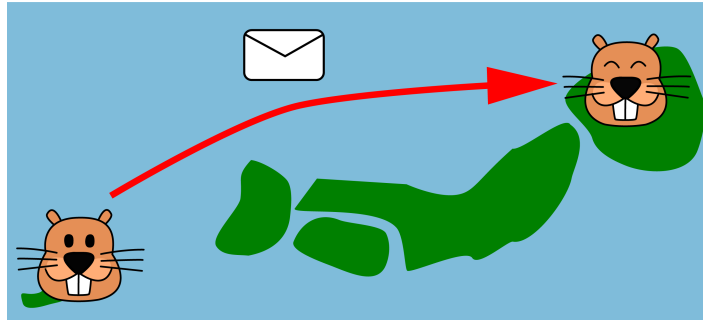

Beavers send messages to each other using sequences of only 0s and 1s. In this system, each letter of the alphabet has its own code. Here are some letters and their codes:

A → 110	B → 111	E → 10	S → 0
---------	---------	--------	-------

The letters of a message are each replaced by their code and the result is 0101011111000.

### Question

What was the message?

- (A) SEEBASE
- (B) SEEBASS
- (C) SEEBESS
- (D) SEEBEES

# Remembering Faces

## Story

Talia is very forgetful, so she has created a system to help her remember the names of her four group members.

If a group member is wearing sunglasses, Talia checks to see if they are wearing a hat. If they are wearing a hat, then it is Ash, otherwise it is Deniz. If the group member is not wearing sunglasses, Talia checks to see if they are wearing a scarf. If they are wearing a scarf, then it is Raul, otherwise it is Ming.

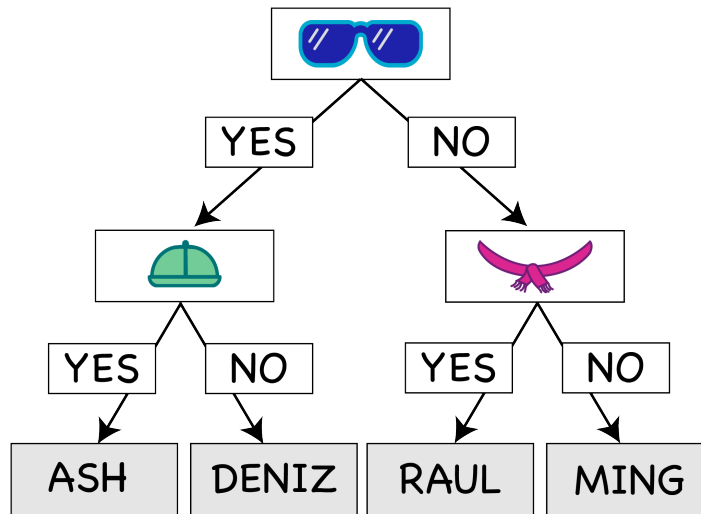

## Question

Which of the following correctly matches names with faces?

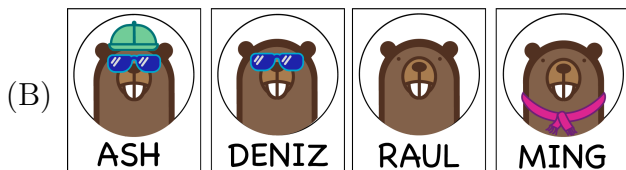
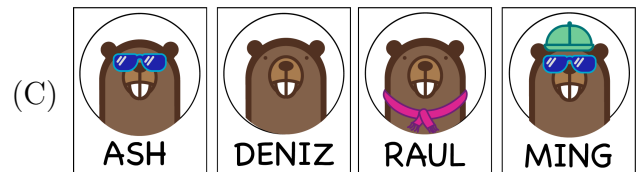
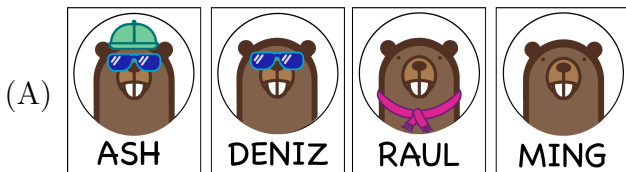

## Target Practice

### Story

Maryam is shooting arrows at the target shown. The number in a ring indicates how many points Maryam scores if an arrow hits that ring.

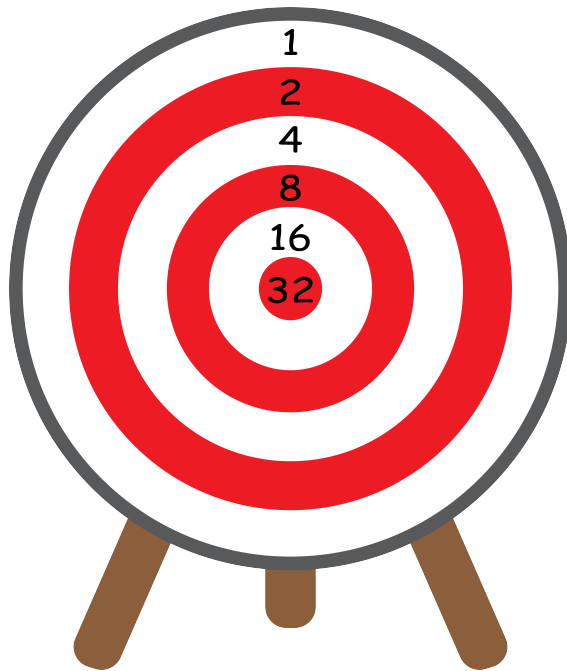

Maryam shoots three arrows and they all hit *different* rings.

### Question

Which total score is **not** possible for Maryam to obtain?

- (A) 56 points
- (B) 21 points
- (C) 10 points
- (D) 7 points

## Part B



# Building Instruction

## Story

In Beaverland, houses are built out of different blocks. A crane takes blocks one by one in a given order. It puts each block either on the base or on top of another block.

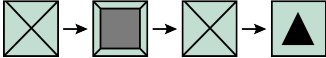
For example, using the block sequence , the following block house can be built.

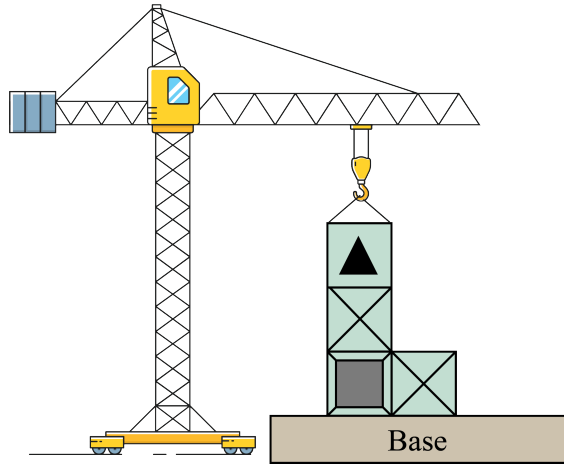

## Question

Which house **cannot** be built out of the following block sequence?

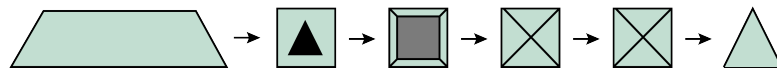

- (A)

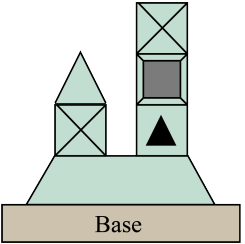

Base

(B)

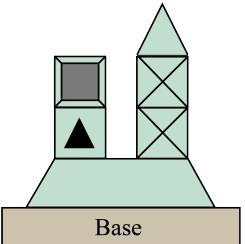

Base

(C)

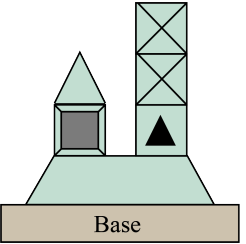

Base

(D)

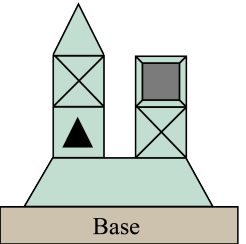

Base

# Nuts and Bolts

## Story

At the Beaver Construction Factory, Lana works on the nuts  and bolts  assembly line.

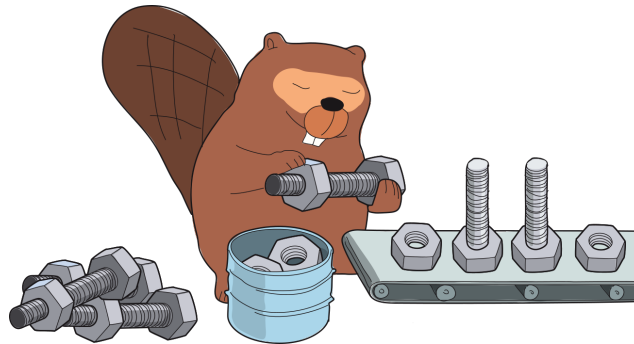

Her job description is as follows:

- Lana stands at one end of a long conveyor belt, which contains a line of nuts and bolts.
- Lana's job is to take each part, either a nut or a bolt, off of the conveyor belt.
- If Lana takes a nut from the conveyor belt, she puts it in the bucket beside her.
- If Lana takes a bolt from the conveyor belt, she takes a nut from the bucket beside her, attaches the nut and bolt together, and adds this to a pile of assembled parts.

However, things can go wrong for Lana in two different ways:

1. Lana takes a bolt from the conveyor belt, and there is no nut in the bucket to attach it to.
2. There are no more bolts on the conveyor belt, and there are still nuts in the bucket.

## Question

Which sequence of nuts and bolts, when processed from left-to-right, will **not** cause things to go wrong for Lana?

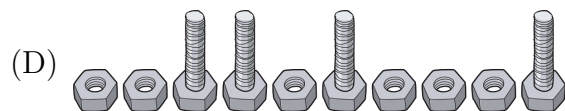
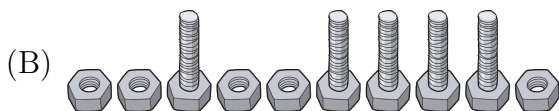
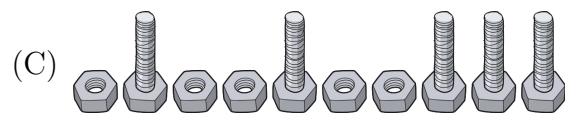
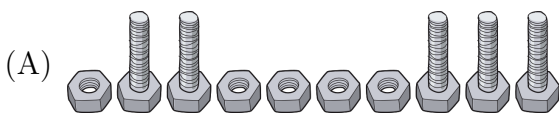

# Lights On

## Story

Beaver Sofia and her friends are playing an arcade game called “Lights On”. The game has 8 buttons for the beavers to stand on. Standing on a button will send a signal down a wire. These wires pass through some triangle or square boxes and eventually lead to a light bulb, as shown.

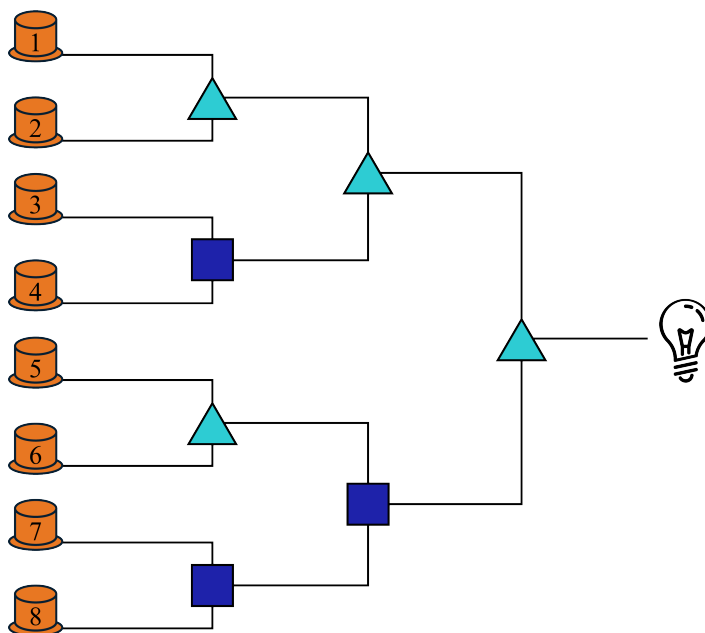

A triangle box will send on a signal if it receives signals from *both* incoming wires.

A square box will send on a signal if it receives a signal from *exactly one* of the incoming wires (in other words, from one of the incoming wires but not the other incoming wire).

The beavers win the game if they can turn the light on.

## Question

Which of the following combinations of buttons could the beavers stand on in order to win the game?

- (A) 2, 3, 4, and 8
- (B) 1, 2, 5, and 6
- (C) 1, 2, 3, 5, 6, and 7
- (D) 1, 2, 4, and 8

# Embroidery Machine

## Story

Benoit has a machine which can embroider two kinds of stitches:  $+$  and  $\times$ . The machine can also move the fabric by the width of one stitch so that stitches are embroidered from left to right.

If the two kinds of stitches are embroidered (in either order) without moving the fabric, the result is:  $*$ .

The machine can be programmed using the characters  $+$ ,  $x$  and  $>$  in some sequence.

- $+$  means to embroider  $+$ ,
- $x$  means to embroider  $\times$ , and
- $>$  means to move the fabric by the width of one stitch.

The machine repeats the entered program some number of times. For example, the program

$+ > + x > x >$

can cause the machine to embroider:

$+ * \times + * \times + * \times + * \times + * \times + * \times + * \times$

## Question

What program can cause the machine to embroider the following?

$\times \times * \times * \times \times * \times * \times \times * \times * \times \times * \times * \times$

- (A)  $x > x > x + > x > + x > x > x >$
- (B)  $x > x > x + > x > x >$
- (C)  $x > x > x + > x > + x >$
- (D)  $+ x > + x > x > + x > x >$

# Talking Tiles

## Story

Terry lives in a terrific town that is built on top of talking tiles. Each tile contains either a house, trees, grass, or stone.

Terry is visually impaired and so he uses the talking tiles to help him navigate. When he steps onto a tile, the talking tile tells him what is found in the four squares surrounding him in the following order: north ( $\uparrow$ ), east ( $\rightarrow$ ), south ( $\downarrow$ ), and west ( $\leftarrow$ ).

Below is a map of the town. Terry is currently standing on the stone tile marked with a star. When he stepped onto this tile, the talking tile said “trees stone house stone”.

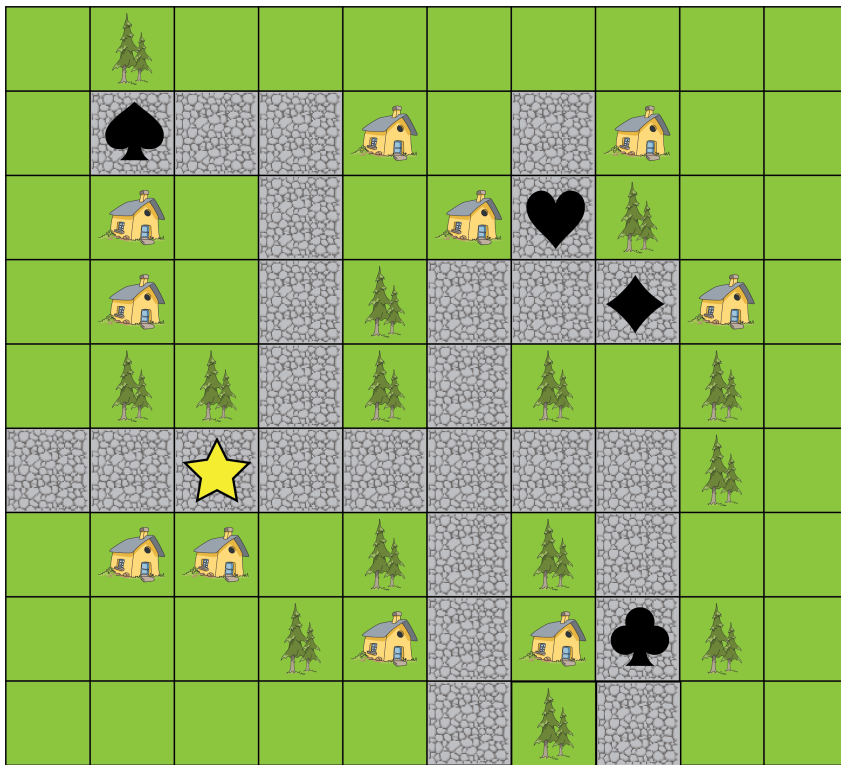

Terry decides to go for a walk around town and hears the following as he walks:

- “stone stone grass stone”
- “trees stone trees stone”
- “stone stone stone stone”
- “stone trees stone trees”
- “house stone stone trees”
- “stone stone trees stone”
- “stone trees stone house”

Terry only walks north, east, south and west.

## Question

Where is Terry now?

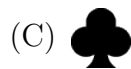
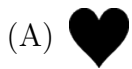



## Part C

## Signal Lamps





### Story

At a small seaside cafe, Bombom takes food orders and Lala does all the cooking. To send food orders to Lala, Bombom uses two signal lamps; one shaped like a leaf, and the other shaped like a flower. At first the cafe sold only coffee and tea and they assigned each item the following codes.

Item	Code
coffee	
tea	

This caused a problem, however, because Lala starts to prepare each drink as soon as she receives a complete code, instead of waiting to see if Bombom is finished. So whenever Bombom turns on the leaf lamp twice, Lala does not wait to see if another signal is sent. Instead, she starts to prepare a coffee, since the complete code for coffee (two leaves) has been sent.

They expanded their menu and assigned new codes to avoid any problems like this. The new menu and codes are as follows.

Item	Code
coffee	
tea	
juice	
sandwich	
muffin	

### Question

If they decide to add pie to the menu, which new code can be used without causing any problems?



# Beach Necklaces

## Story

Bashir makes necklaces using wavy beads and blue beads. He always makes them as follows.

- Place one wavy bead and one blue bead on a string with the wavy bead to the left of the blue bead.

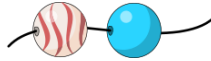

- Do one of the following two actions.

- *Action B*: Add a blue bead to both ends of the string.
- *Action W*: Add two wavy beads to the rightmost end of the string.

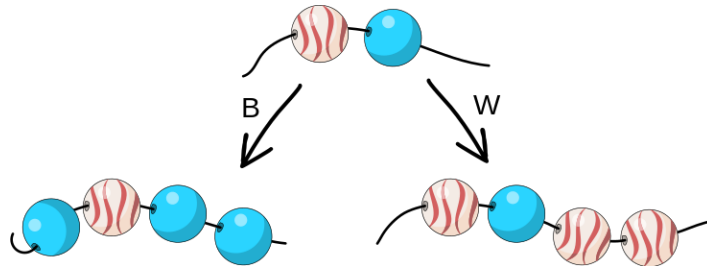

- Repeat step 2 until the necklace is complete.

## Question

Which necklace below **cannot** be made by Bashir?

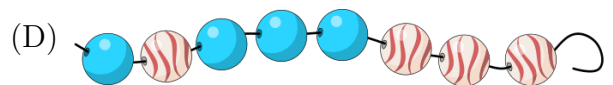
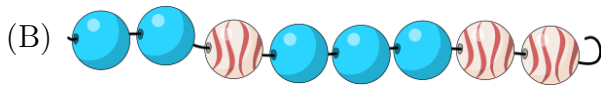
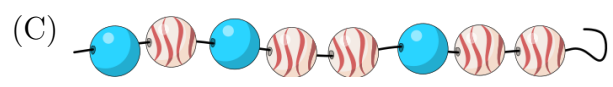
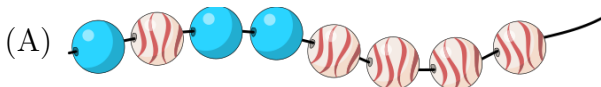



## Beautiful Gems

### Story

Troy has a collection of gems. He ranks his gems from most beautiful to least beautiful.

Sarah knows what gems are in Troy's collection, but she does not know how he has ranked them.

Sarah has a strategy to find out which gem is most beautiful according to Troy:

- Sarah chooses four of Troy's gems and asks Troy: "Out of this group of four, which gem is the most beautiful?"
- Sarah chooses a new set of four gems and asks her question again.
- Then she chooses a third set of four gems and asks her question for the last time.

When Sarah chooses her second and third set of four gems, she may sometimes include gems she has chosen before. Troy answers each question honestly and Sarah remembers all of Troy's answers.

Sarah's strategy allows her to find the most beautiful gem according to Troy, regardless of his ranking.

### Question

What is the largest possible number of gems in Troy's collection?

- (A) 8
- (B) 10
- (C) 11
- (D) 12

## Connected Islands

### Story

A community spread across six islands must connect all the islands together by building bridges. A map of all the possible bridges and the cost of building each bridge is shown.

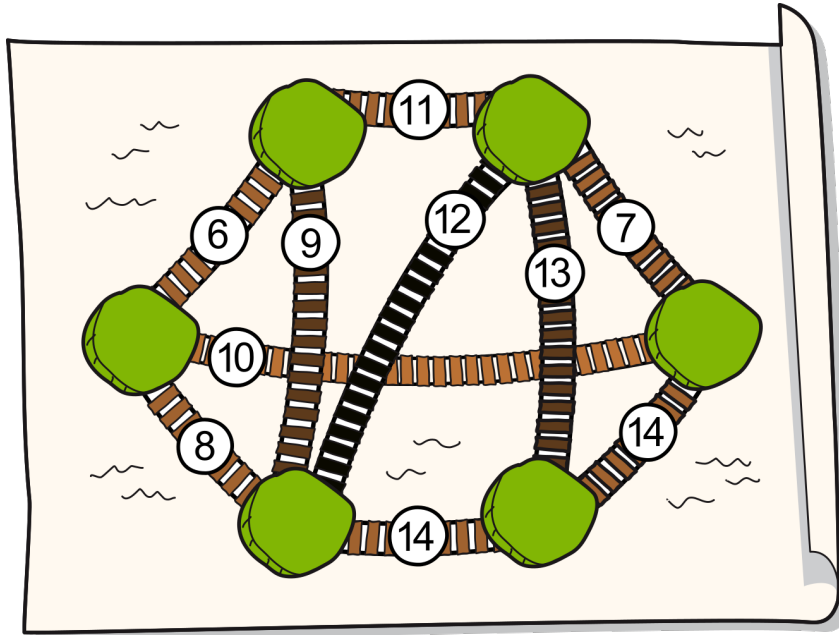

The community needs it to be possible to travel from any island to any other island either directly or indirectly.

Note that when you are on a bridge, you can only leave the bridge where it ends at an island. For example, you cannot hop between the bridges that cost 10 and 13 even though they overlap.

### Question

What is the lowest possible total amount that the community can spend on bridges?

- (A) 46
- (B) 45
- (C) 44
- (D) 40

# Mysteria

## Story

The inhabitants of Mysteria can be wizards, fairies, potions, or dragons. They always arrange themselves in a row and can undergo four types of magical transformations:

1. A wizard can turn into a fairy

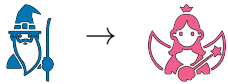

2. A wizard can turn into a wizard (on the left) and a fairy beside them (on the right)



3. A fairy can turn into a potion (on the left) and a dragon (on the right)



4. A fairy can turn into a wizard, with a potion beside them (on the left) and a dragon beside them (on the right)



These magical transformations can happen any number of times, in any order. That is, any wizard and any fairy in Mysteria can transform at any time.

## Question

Starting with the single wizard, which state of Mysteria is **not** possible to obtain?

- (A)
- (B)
- (C)
- (D)