



The CENTRE for EDUCATION  
in MATHEMATICS and COMPUTING  
*cemc.uwaterloo.ca*

## ***2016 Cayley Contest***

(Grade 10)

**Wednesday, February 24, 2016**  
(in North America and South America)

**Thursday, February 25, 2016**  
(outside of North America and South America)

*Solutions*

1. Evaluating,  $(3 + 2) - (2 + 1) = 5 - 3 = 2$ .

ANSWER: (E)

2. According to the graph, 7 of the 20 teachers picked “Square” as their favourite shape.

Thus,  $20 - 7 = 13$  teachers did not pick “Square” as their favourite shape.

(We can also note that the numbers of teachers who chose “Triangle”, “Circle” and “Hexagon” were 3, 4 and 6. The sum of these totals is indeed  $3 + 4 + 6 = 13$ .)

ANSWER: (E)

3. Evaluating,  $\sqrt{5^2 - 4^2} = \sqrt{25 - 16} = \sqrt{9} = 3$ .

ANSWER: (C)

4. Since each of Bill’s steps is  $\frac{1}{2}$  metre long, then 2 of Bill’s steps measure 1 m.

To walk 12 m, Bill thus takes  $12 \times 2 = 24$  steps.

ANSWER: (D)

5. *Solution 1*

Since  $\angle PQS$  is an exterior angle of  $\triangle QSR$ , then  $\angle PQS = \angle QSR + \angle SRQ$ .

Thus,  $2x^\circ = x^\circ + 50^\circ$  and so  $2x = x + 50$  or  $x = 50$ .

*Solution 2*

Since  $\angle PQS$  and  $\angle SQR$  form a straight angle, then  $\angle PQS$  and  $\angle SQR$  are supplementary.

Therefore,  $\angle SQR = 180^\circ - \angle PQS = 180^\circ - 2x^\circ$ .

Since the sum of the angles in  $\triangle SQR$  is  $180^\circ$ , then

$$\begin{aligned}\angle SQR + \angle QSR + \angle QRS &= 180^\circ \\ (180^\circ - 2x^\circ) + x^\circ + 50^\circ &= 180^\circ \\ 50^\circ - x^\circ &= 0^\circ \\ x^\circ &= 50^\circ\end{aligned}$$

Therefore,  $x = 50$ .

ANSWER: (A)

6. Since the slope of the line through points  $(2, 7)$  and  $(a, 3a)$  is 2, then  $\frac{3a - 7}{a - 2} = 2$ .

From this,  $3a - 7 = 2(a - 2)$  and so  $3a - 7 = 2a - 4$  which gives  $a = 3$ .

ANSWER: (C)

7. When Team A played Team B, if Team B won, then Team B scored more goals than Team A, and if the game ended in a tie, then Team A and Team B scored the same number of goals.

Therefore, if a team has 0 wins, 1 loss, and 2 ties, then it scored fewer goals than its opponent once (the 1 loss) and the same number of goals as its opponent twice (the 2 ties).

Combining this information, we see that the team must have scored fewer goals than were scored against them.

In other words, it is not possible for a team to have 0 wins, 1 loss, and 2 ties, and to have scored more goals than were scored against them.

We can also examine choices (A), (B), (D), (E) to see that, in each case, it is possible that the team scored more goals than it allowed.

This will eliminate each of these choices, and allow us to conclude that (C) must be correct.

(A): If the team won 2-0 and 3-0 and tied 1-1, then it scored 6 goals and allowed 1 goal.  
 (B): If the team won 4-0 and lost 1-2 and 2-3, then it scored 7 goals and allowed 5 goals.  
 (D): If the team won 4-0, lost 1-2, and tied 1-1, then it scored 6 goals and allowed 3 goals.  
 (E): If the team won 2-0, and tied 1-1 and 2-2, then it scored 5 goals and allowed 3 goals.  
 Therefore, it is only the case of 0 wins, 1 loss, and 2 ties where it is not possible for the team to score more goals than it allows.

ANSWER: (C)

8. *Solution 1*

We calculate the value of each of the five words as follows:

- The value of  $BAD$  is  $2 + 1 + 4 = 7$
- The value of  $CAB$  is  $3 + 1 + 2 = 6$
- The value of  $DAD$  is  $4 + 1 + 4 = 9$
- The value of  $BEE$  is  $2 + 5 + 5 = 12$
- The value of  $BED$  is  $2 + 5 + 4 = 11$

Of these, the word with the largest value is  $BEE$ .

*Solution 2*

We determine the word with the largest value by comparing the given words. Since  $BAD$  and  $CAB$  share the common letters  $A$  and  $B$ , then the value of  $BAD$  is larger than the value of  $CAB$  because the value of  $D$  is larger than the value of  $C$ . Similarly, the value of  $DAD$  is larger than the value of  $BAD$  (whose value is larger than the value of  $CAB$ ), and the value of  $BEE$  is larger than the value of  $BED$ . Therefore, the two possibilities for the word with the largest value are  $DAD$  and  $BEE$ . The value of  $DAD$  is  $4 + 1 + 4 = 9$  and the value of  $BEE$  is  $2 + 5 + 5 = 12$ . Thus, the word with the largest value is  $BEE$ . (Alternatively, we could note that 2  $E$ 's have a larger value than 2  $D$ 's, and  $B$  has a larger value than  $A$ , so  $BEE$  has a larger value than  $DAD$ .)

ANSWER: (D)

9. *Solution 1*

We write out the numbers in the sequence until we obtain a negative number:

$$43, 39, 35, 31, 27, 23, 19, 15, 11, 7, 3, -1$$

Since each number is 4 less than the number before it, then once a negative number is reached, every following number will be negative.

Thus, Grace writes 11 positive numbers in the sequence.

*Solution 2*

The  $n$ th number in the sequence is  $4(n - 1)$  smaller than the first number, since we will have subtracted 4 a total of  $n - 1$  times to obtain the  $n$ th number.

Therefore, the  $n$ th number is  $43 - 4(n - 1) = 47 - 4n$ .

The first positive integer  $n$  for which this expression is negative is  $n = 12$ .

Therefore, Grace writes 11 positive numbers in the sequence.

ANSWER: (A)

10. *Solution 1*

We label the players as A, B, C, D, and E.

The total number of matches played will be equal to the number of pairs of players that can be formed times the number of matches that each pair plays.

The possible pairs of players are AB, AC, AD, AE, BC, BD, BE, CD, CE, and DE. There are 10 such pairs.

Thus, the total number of matches played is  $10 \times 3 = 30$ .

*Solution 2*

Each student plays each of the other 4 students 3 times and so plays in  $4 \times 3 = 12$  matches.

Since there are 5 students, then the students play in a total of  $5 \times 12 = 60$  matches.

But each match includes 2 students, so each match is counted twice in the number of matches in which students play (60). Thus, the total number of matches played is  $60 \div 2 = 30$ .

ANSWER: (C)

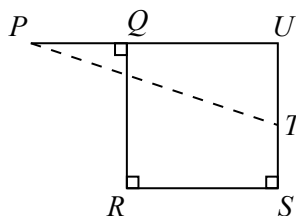
11. Extend  $PQ$  and  $ST$  to meet at  $U$ .

Since  $QUSR$  has three right angles, then it must have four right angles and so is a rectangle. Thus,  $\triangle PUT$  is right-angled at  $U$ .

By the Pythagorean Theorem,  $PT^2 = PU^2 + UT^2$ .

Now  $PU = PQ + QU$  and  $QU = RS$  so  $PU = 4 + 8 = 12$ .

Also,  $UT = US - ST$  and  $US = QR$  so  $UT = 8 - 3 = 5$ .

Therefore,  $PT^2 = 12^2 + 5^2 = 144 + 25 = 169$ .

Since  $PT > 0$ , then  $PT = \sqrt{169} = 13$ .

ANSWER: (E)

## 12. Since Alejandro selects one ball out of a box that contains 30 balls, then the possibility that is the most likely is the one that is satisfied by the largest number of balls in the box.

There are 3 balls in the box whose number is a multiple of 10. (These are 10, 20, 30.)

There are 15 balls in the box whose number is odd. (These are the numbers whose ones digits are 1, 3, 5, 7, or 9.)

There are 4 balls in the box whose number includes the digit 3. (These are 3, 13, 23, and 30.)

There are 6 balls in the box whose number is a multiple of 5. (These are 5, 10, 15, 20, 25, 30.)

There are 12 balls in the box whose number includes the digit 2. (These are 2, 12, and the then integers from 20 to 29, inclusive.)

The most likely of these outcomes is that he selects a ball whose number is odd.

ANSWER: (B)

13. We note that  $\frac{1}{6} = \frac{5}{30}$  and that  $\frac{1}{4} = \frac{5}{20}$ .

If we compare two fractions with equal positive numerators, the fraction with the smaller positive denominator will be largest of the two fractions.

Therefore,  $\frac{5}{30} < \frac{5}{24}$  and  $\frac{5}{24} < \frac{5}{20}$ , or  $\frac{1}{6} < \frac{5}{24} < \frac{1}{4}$ .

(Alternatively, we could note that since  $\frac{1}{6} = \frac{6}{24}$  and that  $\frac{1}{4} = \frac{6}{24}$ , then  $\frac{5}{24}$  must be the one of the given choices that is between these.)

ANSWER: (C)

14. Since  $100 = 10^2$ , then  $100^{10} = (10^2)^{10} = 10^{20}$ .

Therefore,  $(10^{100}) \times (100^{10}) = (10^{100}) \times (10^{20}) = 10^{120}$ .

When written out, this integer consists of a 1 followed by 120 zeros.

ANSWER: (A)

15. We note that  $20 = 2^2 \cdot 5$  and  $16 = 2^4$  and  $2016 = 16 \cdot 126 = 2^5 \cdot 3^2 \cdot 7$ .

For an integer to be divisible by each of  $2^2 \cdot 5$  and  $2^4$  and  $2^5 \cdot 3^2 \cdot 7$ , it must include at least 5 factors of 2, at least 2 factors of 3, at least 1 factor of 5, and at least 1 factor of 7.

The smallest such positive integer is  $2^5 \cdot 3^2 \cdot 5^1 \cdot 7^1 = 10\,080$ . The tens digit of this integer is 8.

ANSWER: (E)

16. The three diagrams below show first the original position of the triangle, the position after it is reflected in the  $x$ -axis, and then the position when this result is reflected in the  $y$ -axis:

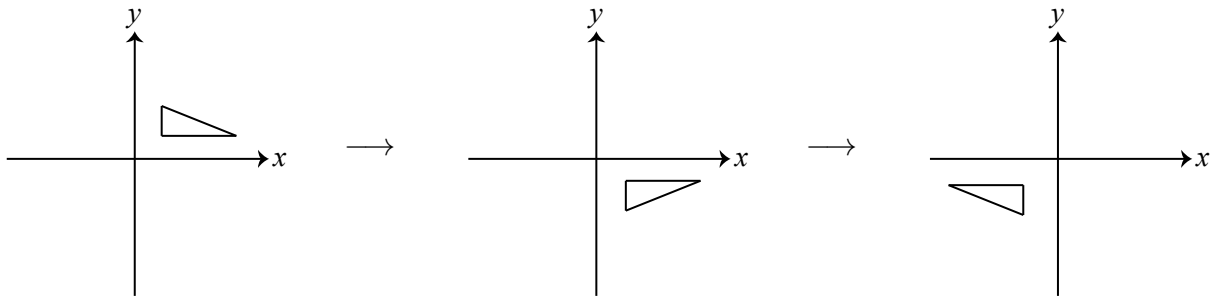

The final position is seen in (D).

ANSWER: (D)

17. Since the perimeter of square  $PQRS$  is 120, then its side length is  $\frac{1}{4}(120) = 30$ .

Therefore,  $PQ = QR = RS = SP = 30$ .

Since the perimeter of  $\triangle PZS$  is  $2x$ , then  $PZ + ZS + SP = 2x$ .

Since  $PS = 30$ , then  $PZ + ZS = 2x - PS = 2x - 30$ .

Therefore, the perimeter of pentagon  $PQRSZ$  is

$$PQ + QR + RS + ZS + PZ = 30 + 30 + 30 + (PZ + ZS) = 30 + 30 + 30 + (2x - 30) = 2x + 60$$

which equals  $60 + 2x$ .

ANSWER: (C)

18. *Solution 1*

Suppose that the three integers are  $x$ ,  $y$  and  $z$  where  $x + y = 998$  and  $x + z = 1050$  and  $y + z = 1234$ .

From the first two equations,  $(x + z) - (x + y) = 1050 - 998$  or  $z - y = 52$ .

Since  $z + y = 1234$  and  $z - y = 52$ , then  $(z + y) + (z - y) = 1234 + 52$  or  $2z = 1286$  and so  $z = 643$ .

Since  $z = 643$  and  $z - y = 52$ , then  $y = z - 52 = 643 - 52 = 591$ .

Since  $x + y = 998$  and  $y = 591$ , then  $x = 998 - y = 998 - 591 = 407$ .

The three original numbers are 407, 591 and 643.

The difference between the largest and smallest of these integers is  $643 - 407 = 236$ .

*Solution 2*

Suppose that the three numbers are  $x$ ,  $y$  and  $z$ , and that  $x \leq y \leq z$ .

Since  $y \leq z$ , then  $x + y \leq x + z$ .

Since  $x \leq y$ , then  $x + z \leq y + z$ .

Therefore,  $x + y \leq x + z \leq y + z$ .

This tells us that  $x + y = 998$ ,  $x + z = 1050$ , and  $y + z = 1234$ .

Since  $z$  is the largest and  $x$  is the smallest of the three original integers, we want to determine the value of  $z - x$ .

But  $z - x = (y + z) - (x + y) = 1234 - 998 = 236$ .

ANSWER: (E)

19. The number of points on the circle equals the number of spaces between the points around the circle.

Moving from the point labelled 7 to the point labelled 35 requires moving  $35 - 7 = 28$  points and so 28 spaces around the circle.

Since the points labelled 7 and 35 are diametrically opposite, then moving along the circle from 7 to 35 results in travelling halfway around the circle.

Since 28 spaces makes half of the circle, then  $2 \cdot 28 = 56$  spaces make the whole circle.

Thus, there are 56 points on the circle, and so  $n = 56$ .

ANSWER: (C)

20. *Solution 1*

Suppose that, when the  $n$  students are put in groups of 2, there are  $g$  complete groups and 1 incomplete group.

Since the students are being put in groups of 2, an incomplete group must have exactly 1 student in it.

Therefore,  $n = 2g + 1$ .

Since the number of complete groups of 2 is 5 more than the number of complete groups of 3, then there were  $g - 5$  complete groups of 3.

Since there was still an incomplete group, this incomplete group must have had exactly 1 or 2 students in it.

Therefore,  $n = 3(g - 5) + 1$  or  $n = 3(g - 5) + 2$ .

If  $n = 2g + 1$  and  $n = 3(g - 5) + 1$ , then  $2g + 1 = 3(g - 5) + 1$  or  $2g + 1 = 3g - 14$  and so  $g = 15$ . In this case,  $n = 2g + 1 = 31$  and there were 15 complete groups of 2 and 10 complete groups of 3.

If  $n = 2g + 1$  and  $n = 3(g - 5) + 2$ , then  $2g + 1 = 3(g - 5) + 2$  or  $2g + 1 = 3g - 13$  and so  $g = 14$ . In this case,  $n = 2g + 1 = 29$  and there were 14 complete groups of 2 and 9 complete groups of 3.

If  $n = 31$ , dividing the students into groups of 4 would give 7 complete groups of 4 and 1 incomplete group.

If  $n = 29$ , dividing the students into groups of 4 would give 7 complete groups of 4 and 1 incomplete group.

Since the difference between the number of complete groups of 3 and the number of complete groups of 4 is given to be 3, then it must be the case that  $n = 31$ .

In this case,  $n^2 - n = 31^2 - 31 = 930$ ; the sum of the digits of  $n^2 - n$  is 12.

*Solution 2*

Since the  $n$  students cannot be divided exactly into groups of 2, 3 or 4, then  $n$  is not a multiple of 2, 3 or 4.

The first few integers larger than 1 that are not divisible by 2, 3 or 4 are 5, 7, 11, 13, 17, 19, 23, 25, 29, 31, and 35.

In each case, we determine the number of complete groups of each size:

$n$	5	7	11	13	17	19	23	25	29	31	35
# of complete groups of 2	2	3	5	6	8	9	11	12	14	15	17
# of complete groups of 3	1	2	3	4	5	6	7	8	9	10	11
# of complete groups of 4	1	1	2	3	4	4	5	6	7	7	8

Since the number of complete groups of 2 is 5 more than the number of complete groups of 3 which is 3 more than the number of complete groups of 4, then of these possibilities,  $n = 31$  works.

In this case,  $n^2 - n = 31^2 - 31 = 930$ ; the sum of the digits of  $n^2 - n$  is 12.

(Since the problem is a multiple choice problem and we have found a value of  $n$  that satisfies the given conditions and for which an answer is present, then this answer must be correct. Solution 1 shows why  $n = 31$  is the only value of  $n$  that satisfies the given conditions.)

ANSWER: (B)

21. Suppose that Jackie had played  $n$  games before her last game.

Since she scored an average of 20 points per game over these  $n$  games, then she scored  $20n$  points over these  $n$  games.

In her last game, she scored 36 points and so she has now scored  $20n + 36$  points in total.

But, after her last game, she has now played  $n + 1$  games and has an average of 21 points scored per game.

Therefore, we can also say that her total number of points scored is  $21(n + 1)$ .

Thus,  $21(n + 1) = 20n + 36$  or  $21n + 21 = 20n + 36$  and so  $n = 15$ .

This tells us that after 16 games, Jackie has scored  $20(15) + 36 = 336$  points.

For her average to be 22 points per game after 17 games, she must have scored a total of  $17 \cdot 22 = 374$  points.

This would mean that she must score  $374 - 336 = 38$  points in her next game.

ANSWER: (A)

22. Since the track is circular with radius 25 km, then its circumference is  $2\pi(25) = 50\pi$  km.

In the 15 minutes that Alain drives at 80 km/h, he drives a distance of  $\frac{1}{4}(80) = 20$  km (because 15 minutes is one-quarter of an hour).

When Louise starts driving, she drives in the opposite direction to Alain.

Suppose that Alain and Louise meet for the first time after Louise has been driving for  $t$  hours.

During this time, Louise drives at 100 km/h, and so drives  $100t$  km.

During this time, Alain drives at 80 km/h, and so drives  $80t$  km.

Since they start  $50\pi - 20$  km apart along the track (the entire circumference minus the 20 km that Alain drove initially), then the sum of the distances that they travel is  $50\pi - 20$  km.

Therefore,  $100t + 80t = 50\pi - 20$  and so  $180t = 50\pi - 20$  or  $t = \frac{5\pi - 2}{18}$ .

Suppose that Alain and Louise meet for the next time after an additional  $T$  hours.

During this time, Louise drives  $100T$  km and Alain drives  $80T$  km.

In this case, the sum of the distances that they drive is the complete circumference of the track, or  $50\pi$  km. Thus,  $180T = 50\pi$  or  $T = \frac{5\pi}{18}$ .

The length of time between the first and second meetings will be the same as the amount of time between the second and third, and between the third and fourth meetings.

Therefore, the total time that Louise has been driving when she and Alain meet for the fourth time will be  $t + 3T = \frac{5\pi - 2}{18} + 3 \cdot \frac{5\pi}{18} = \frac{20\pi - 2}{18} = \frac{10\pi - 1}{9}$  hours.

ANSWER: (C)

23. If the four sides that are chosen are adjacent, then when these four sides are extended, they will not form a quadrilateral that encloses the octagon. (See Figure 1.)

If the four sides are chosen so that there are exactly three adjacent sides that are not chosen and one other side not chosen, then when these four sides are extended, they will not form a quadrilateral that encloses the octagon. (See Figures 2 and 3.)

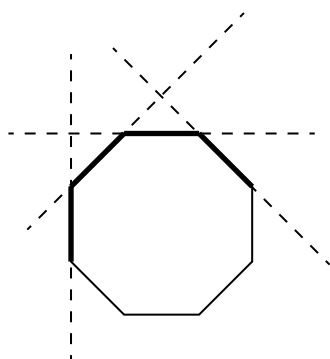

Figure 1

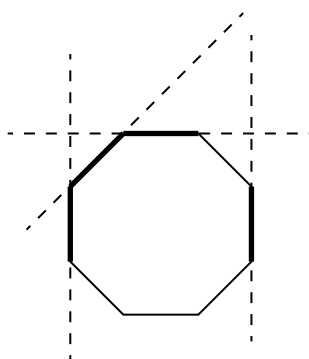

Figure 2

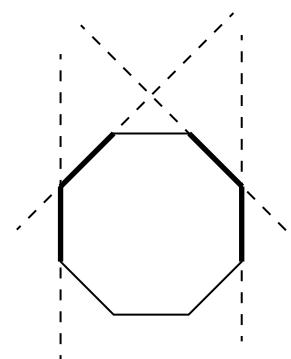

Figure 3

Any other set of four sides that are chosen will form a quadrilateral that encloses the octagon. This is true based on the following argument:

Suppose that side  $s_1$  is chosen and that  $s_2$  is the next side chosen in a clockwise direction.

These two sides will either be adjacent (Figure 4) or have one unchosen side between them (Figure 5) or will have two unchosen sides between them (Figure 6). (They cannot have three or four adjacent unchosen sides between them from the previous argument. They cannot have more than four adjacent unchosen sides between them since four sides have to be chosen.)

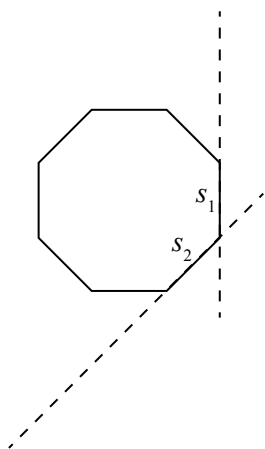

Figure 4

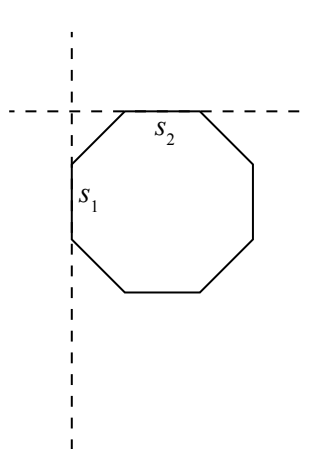

Figure 5

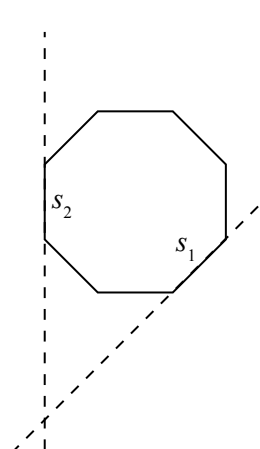

Figure 6

In each of these cases, sides  $s_1$  and  $s_2$  when extended meet on or outside the octagon and “between”  $s_1$  and  $s_2$ .

Continue the process to choose  $s_3$  and  $s_4$  in such a way as there are not three or four adjacent unchosen sides between any consecutive pair of chosen sides.

Since each consecutive pair of chosen sides meets between the two sides and on or outside the octagon, then these four meeting points (between  $s_1$  and  $s_2$ ,  $s_2$  and  $s_3$ ,  $s_3$



and  $s_4$ , and  $s_4$  and  $s_1$ ) and the line segments joining them will form a quadrilateral that includes the octagon. (An example is shown in Figure 7.)

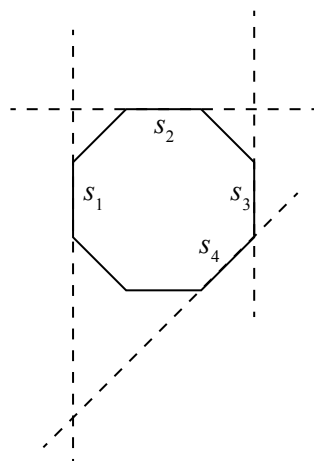

Figure 7

We are told that there is a total of 70 ways in which four sides can be chosen.

We will count the number of ways in which four sides can be chosen that do not result in the desired quadrilateral, and subtract this from 70 to determine the number of ways in which the desired quadrilateral does result.

There are 8 ways in which to choose four adjacent sides: choose one side to start (there are 8 ways to choose one side) and then choose the next three adjacent sides in clockwise order (there is 1 way to do this).

There are 8 ways to choose adjacent sides to be not chosen (after picking one such set, there are 7 additional positions into which these sides can be rotated). For each of these choices, there are 3 possible choices for the remaining unchosen sides. (Figures 2 and 3 give two of these choices; the third choice is the reflection of Figure 2 through a vertical line.) Therefore, there are  $8 \times 3 = 24$  ways to choose four sides so that there are 3 adjacent sides unchosen.

Therefore, of the 70 ways of choosing four sides, exactly  $8 + 24 = 32$  of them do not give the desired quadrilateral, and so  $70 - 32 = 38$  ways do.

Thus, the probability that four sides are chosen so that the desired quadrilateral is formed is  $\frac{38}{70} = \frac{19}{35}$ .

ANSWER: (B)

24. Suppose that a number  $q$  has the property that there are exactly 19 integers  $n$  with  $\sqrt{q} < n < q$ . Suppose that these 19 integers are  $m, m + 1, m + 2, \dots, m + 17, m + 18$ .

Then  $\sqrt{q} < m < m + 1 < m + 2 < \dots < m + 17 < m + 18 < q$ .

This tells us that  $q - \sqrt{q} > (m + 18) - m = 18$  because  $q - \sqrt{q}$  is as small as possible when  $q$  is as small as possible and  $\sqrt{q}$  is as large as possible.

Also, since this is exactly the list of integers that is included strictly between  $\sqrt{q}$  and  $q$ , then we must have  $m - 1 \leq \sqrt{q} < m < m + 1 < m + 2 < \dots < m + 17 < m + 18 < q \leq m + 19$ .

In other words, neither  $m - 1$  nor  $m + 19$  can satisfy  $\sqrt{q} < n < q$ .

This tells us that  $q - \sqrt{q} \leq (m + 19) - (m - 1) = 20$ .

Therefore, we have that  $18 < q - \sqrt{q} \leq 20$ .

Next, we use  $18 < q - \sqrt{q} \leq 20$  to get a restriction on  $q$  itself.

To have  $q - \sqrt{q} > 18$ , we certainly need  $q > 18$ .

But if  $q > 18$ , then  $\sqrt{q} > \sqrt{18} > 4$ .

Furthermore,  $q - \sqrt{q} > 18$  and  $\sqrt{q} > 4$  give  $q - 4 > q - \sqrt{q} > 18$  and so  $q > 22$ .

Next, note that  $q - \sqrt{q} = \sqrt{q}(\sqrt{q} - 1)$ .

When  $q$  is larger than 1 and increases, each factor  $\sqrt{q}$  and  $\sqrt{q} - 1$  increases, so the product  $q - \sqrt{q}$  increases.

When  $q = 25$ ,  $q - \sqrt{q} = 25 - 5 = 20$ .

Since we need  $q - \sqrt{q} \leq 20$  and since  $q - \sqrt{q} = 20$  when  $q = 25$  and since  $q - \sqrt{q}$  is increasing, then for  $q - \sqrt{q} \leq 20$ , we must have  $q \leq 25$ .

Therefore,  $18 < q - \sqrt{q} \leq 20$  tells us that  $22 < q \leq 25$ .

So we limit our search for  $q$  to this range.

When  $q = 22$ ,  $\sqrt{q} \approx 4.69$ , and so the integers  $n$  that satisfy  $\sqrt{q} < n < q$  are  $5, 6, 7, \dots, 20, 21$ , of which there are 17.

When  $22 < q \leq 23$ , we have  $4 < \sqrt{q} < 5$  and  $22 < q \leq 23$ , which means that the integers  $n$  that satisfy  $\sqrt{q} < n < q$  are  $5, 6, 7, \dots, 20, 21, 22$ , of which there are 18.

When  $23 < q \leq 24$ , we have  $4 < \sqrt{q} < 5$  and  $23 < q \leq 24$ , which means that the integers  $n$  that satisfy  $\sqrt{q} < n < q$  are  $5, 6, 7, \dots, 20, 21, 22, 23$ , of which there are 19.

When  $24 < q < 25$ , we have  $4 < \sqrt{q} < 5$  and  $24 < q < 25$ , which means that the integers  $n$  that satisfy  $\sqrt{q} < n < q$  are  $5, 6, 7, \dots, 20, 21, 22, 23, 24$ , of which there are 20.

When  $q = 25$ ,  $\sqrt{q} = 5$  and so the integers that satisfy  $\sqrt{q} < n < q$  are  $6, 7, \dots, 20, 21, 22, 23, 24$ , of which there are 19.

Therefore, the numbers  $q$  for which there are exactly 19 integers  $n$  that satisfy  $\sqrt{q} < n < q$  are  $q = 25$  and those  $q$  that satisfy  $23 < q \leq 24$ .

Finally, we must determine the sum of all such  $q$  that are of the form  $q = \frac{a}{b}$  where  $a$  and  $b$  are positive integers with  $b \leq 10$ .

The integers  $q = 24$  and  $q = 25$  are of this form with  $a = 24$  and  $a = 25$ , respectively, and  $b = 1$ .

The  $q$  between 23 and 24 that are of this form with  $b \leq 4$  are

$$23\frac{1}{2} = \frac{47}{2}, 23\frac{1}{3} = \frac{70}{3}, 23\frac{2}{3} = \frac{71}{3}, 23\frac{1}{4} = \frac{93}{4}, 23\frac{3}{4} = \frac{95}{4}$$

Notice that we don't include  $23\frac{2}{4}$  since this is the same as the number  $23\frac{1}{2}$ .

We continue by including those satisfying  $5 \leq b \leq 10$  and not including equivalent numbers that have already been included with smaller denominators, we obtain

$$23\frac{1}{2}, 23\frac{1}{3}, 23\frac{2}{3}, 23\frac{1}{4}, 23\frac{3}{4}, 23\frac{1}{5}, 23\frac{2}{5}, 23\frac{3}{5}, 23\frac{4}{5}, 23\frac{1}{6}, 23\frac{5}{6}, 23\frac{1}{7}, 23\frac{2}{7}, 23\frac{3}{7}, 23\frac{4}{7}, 23\frac{5}{7}, 23\frac{6}{7},$$

$$23\frac{1}{8}, 23\frac{3}{8}, 23\frac{5}{8}, 23\frac{7}{8}, 23\frac{1}{9}, 23\frac{2}{9}, 23\frac{4}{9}, 23\frac{5}{9}, 23\frac{7}{9}, 23\frac{8}{9}, 23\frac{1}{10}, 23\frac{3}{10}, 23\frac{7}{10}, 23\frac{9}{10}$$

There are 31 numbers in this list.

Each of these 31 numbers equals 23 plus a fraction between 0 and 1.

With the exception of the one number with denominator 2, each of the fractions can be paired with another fraction with the same denominator to obtain a sum of 1. (For example,  $\frac{1}{5} + \frac{4}{5} = 1$  and  $\frac{2}{5} + \frac{3}{5} = 1$ .)

Therefore, the sum of all of these  $q$  between 23 and 24 is  $31(23) + \frac{1}{2} + 15(1) = 728\frac{1}{2}$ , because there are 31 contributions of 23 plus the fraction  $\frac{1}{2}$  plus 15 pairs of fractions with a sum of 1.

Finally, the sum of all  $q$  of the proper form for which there are exactly 19 integers that satisfy  $\sqrt{q} < n < q$  is  $728\frac{1}{2} + 25 + 24 = 777\frac{1}{2}$ .

ANSWER: (C)

25. Using the given rules, the words that are 1 letter long are A, B, C, D, E.

Using the given rules, the words that are 2 letters long are AB, AC, AD, BA, BC, BD, BE, CA, CB, CD, CE, DA, DB, DC, DE, EB, EC, ED.

Let  $v_n$  be the number of words that are  $n$  letters long and that begin with a vowel. Note that  $v_1 = 2$  and  $v_2 = 6$ .

Let  $c_n$  be the number of words that are  $n$  letters long and that begin with a consonant. Note that  $c_1 = 3$  and  $c_2 = 12$ .

Suppose  $n \geq 2$ .

Consider a word of length  $n$  that begins with a vowel (that is, with A or E).

Since two vowels cannot occur in a row, the second letter of this word must be B, C or D.

This means that every word of length  $n$  that begins with a vowel can be transformed into a word of length  $n - 1$  that begins with a consonant by removing the first letter.

Also, each word of length  $n - 1$  that begins with a consonant can form two different words of length  $n$  that begin with a vowel.

Therefore,  $v_n = 2c_{n-1}$ .

Consider a word of length  $n$  that begins with a consonant.

Since the same letter cannot occur twice in a row, then the second letter of this word is either a vowel or a different consonant than the first letter of the word.

Each word of length  $n - 1$  that begins with a vowel can form 3 words of length  $n$  that begin with a consonant, obtained by adding B, C, D to the start of the word.

Each word of length  $n - 1$  that begins with a consonant can form 2 words of length  $n$  that begin with a consonant, obtained by adding each of the consonants other than the one with which the word of length  $n - 1$  starts.

Therefore,  $c_n = 3v_{n-1} + 2c_{n-1}$ .

We note from above that  $v_1 = 2$  and  $c_1 = 3$ .

The equations  $v_2 = 2c_1$  and  $c_2 = 3v_1 + 2c_1$  are consistent with the information that  $v_2 = 6$  and  $c_2 = 12$ .

Since  $v_2 = 6$  and  $c_2 = 12$ , then  $v_3 = 2c_2 = 24$  and  $c_3 = 3v_2 + 2c_2 = 3(6) + 2(12) = 42$ .

We want to determine  $v_{10}$ .

We continue these calculations and make a table:

$n$	$v_n$	$c_n$
1	2	3
2	6	12
3	24	42
4	84	156
5	312	564
6	1128	2064
7	4128	7512
8	15 024	27 408
9	54 816	99 888
10	199 776	364 224

Therefore, there are 199 776 words of length 10 that begin with a vowel.

ANSWER: (E)