

Problem

In the set of figures below, sides of equal length are indicated by a ‘|’ or ‘||’.

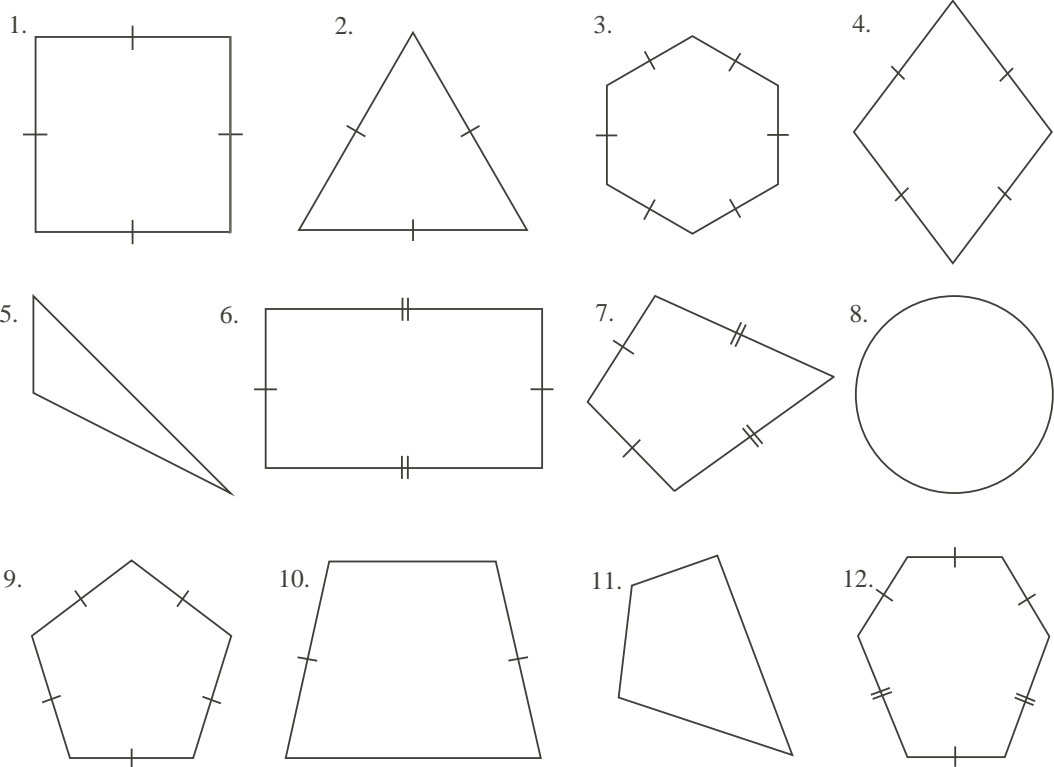

Use the enlarged diagrams on the following page in answering questions a) to d).

- a) Give a name for each figure.
- b) Which figures have only one line of symmetry? Draw the line on each such figure.
- c) Which figures have exactly two lines of symmetry? Draw the lines on each such figure.
- d) Are there any figures with more than four lines of symmetry? If so, which figures?

Extension:

1. Which figures would you describe as having a centre point? Why?

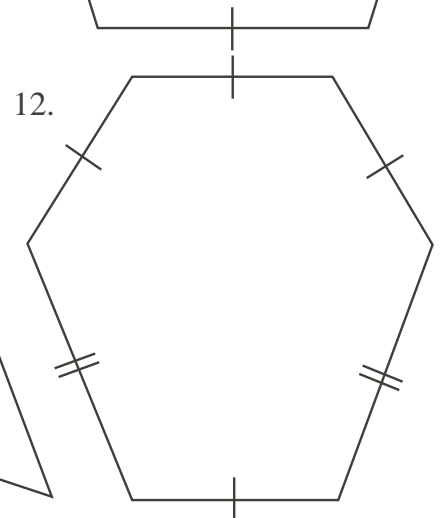
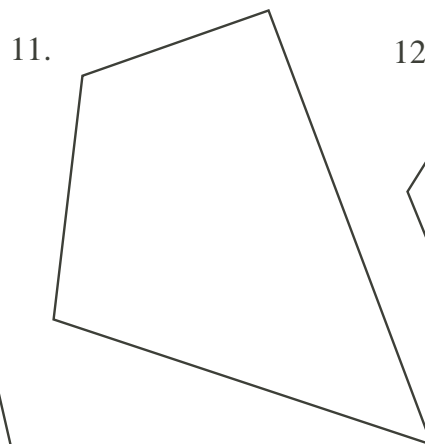
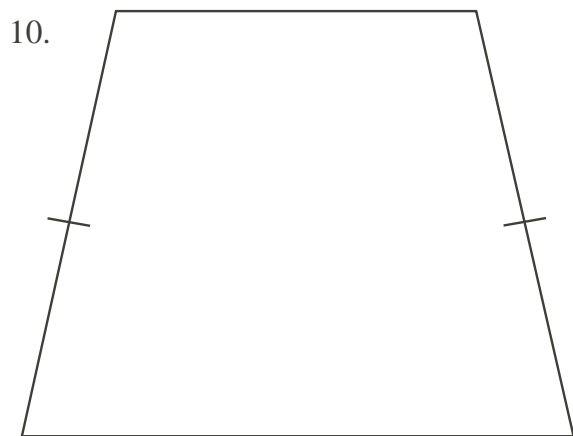
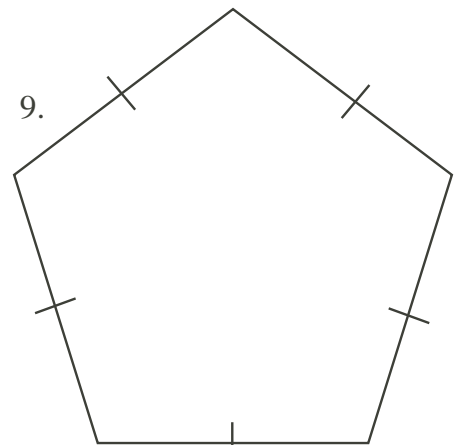
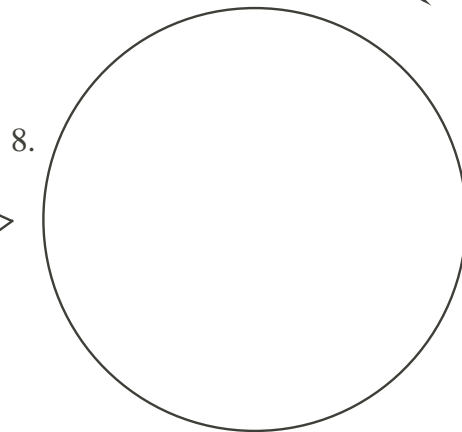
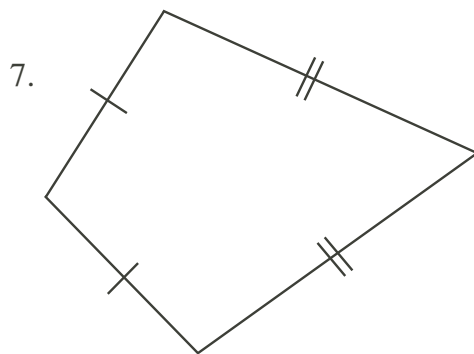
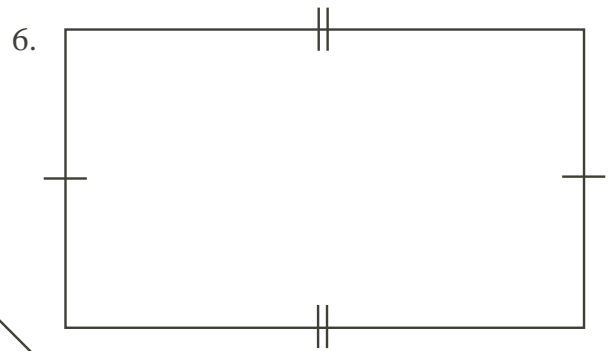
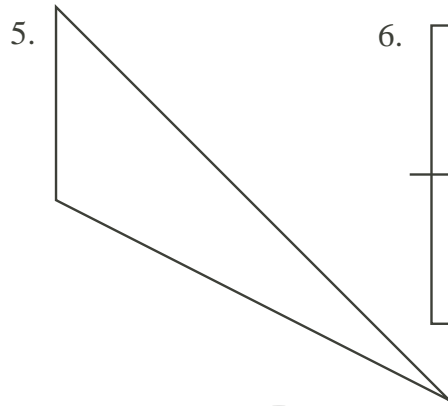
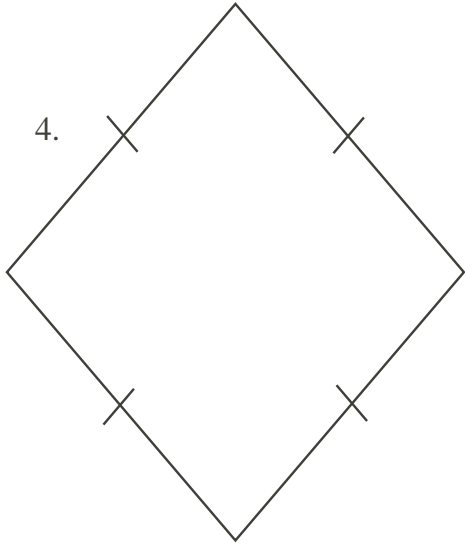
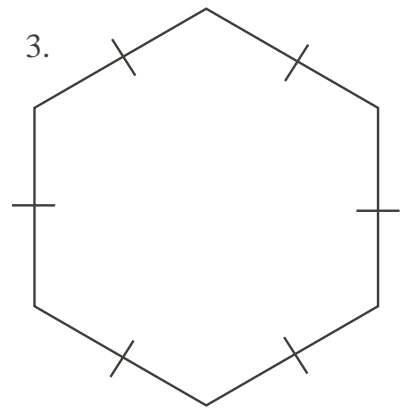
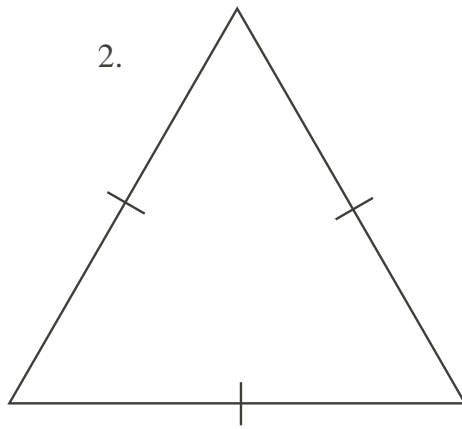
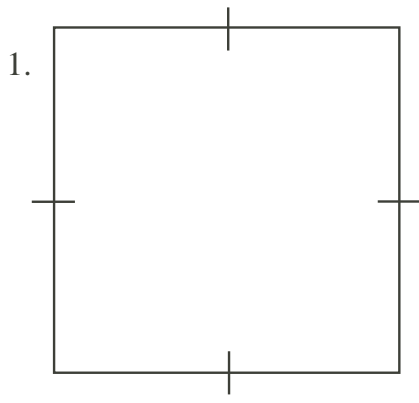

Hints

Hint 1 - What is a line of symmetry?

Suggestions:

1. If your students are new to the names of two-dimensional figures, make a list of the 12 names (from the solutions below), in random order, on the blackboard, and have the class match them to the figures.
2. You may wish to suggest that your students cut out the enlarged figures and fold to verify the lines of symmetry.
3. Before students try the extension, you may wish to have a class discussion about what constitutes a *centre point* of a geometric figure.

Solution

Part a)

Possible names include:

- | | | | |
|------------------------|-------------------------------|-------------------------|----------------------------|
| 1 - square | 2 - (equilateral) triangle | 3 - (regular) hexagon | 4 - rhombus, diamond |
| 5 - (scalene) triangle | 6 - rectangle | 7 - quadrilateral, kite | 8 - circle |
| 9 - regular pentagon | 10 - trapezoid /quadrilateral | 11 - quadrilateral | 12 - (non-regular) hexagon |

Part b), c), d)

The diagrams below show all lines of symmetry, except for the circle, which has infinitely many lines of symmetry (all diagonals). They reveal that Figures 7, 10, 12 have only one line of symmetry, Figures 4 and 6 have exactly two lines of symmetry, Figure 1 has four, and Figures 3, 8, and 9 have more than 4 lines of symmetry.

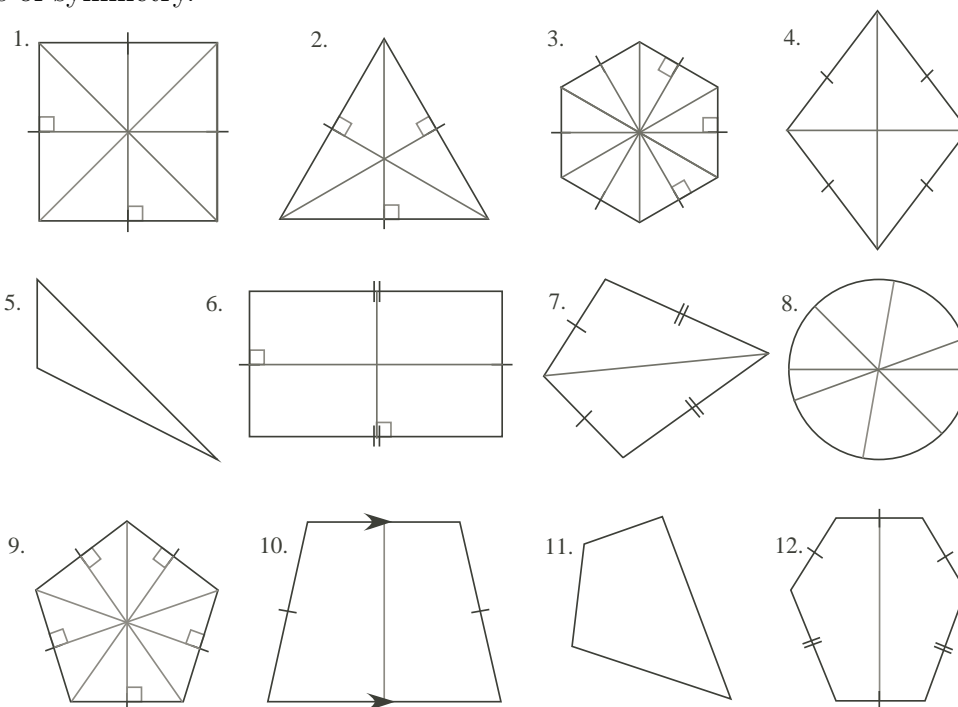

Extension:

1. A reasonable definition is to say that a figure has a centre point if it has two or more lines of symmetry meeting in a common point. That point is then the centre point.