



The CENTRE for EDUCATION
in MATHEMATICS and COMPUTING
cemc.uwaterloo.ca

From the archives of the CEMC

April 2017 Solutions

In honour of the 50th anniversary of the Faculty of Mathematics, at the beginning of each month of 2017, a set of five problems from the 54 years of CEMC contests will be posted. Solutions to the problems will be posted at the beginning of the next month. Hopefully, these problems will intrigue and inspire your mathematical mind. For more problem solving resources, please visit cemc.uwaterloo.ca.

1. 1975 Junior Mathematics Contest, Question 23

In a semi-circle, AB and CD are parallel chords of lengths 24 and 10 respectively. The distance between these chords is 7. The radius of the semi-circle is

- (A) 12 (B) 15 (C) 14 (D) 17 (E) 13

Solution

Let O be the centre of the circle.

Draw the perpendicular OML to the chords, as below.

Then L bisects CD and M bisects AB .

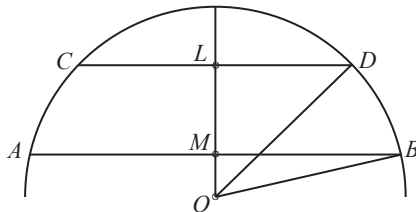

Since OD and OB are radii, then $OD = OB$.

Let $OM = a$.

Hence,

$$\begin{aligned} OD^2 &= OB^2 \\ OL^2 + LD^2 &= OM^2 + MB^2 && \text{(By the Pythagorean Theorem)} \\ (a + 7)^2 + 5^2 &= a^2 + 12^2 \\ a^2 + 14a + 49 + 25 &= a^2 + 144 \\ 14a &= 70 \\ a &= 5 \end{aligned}$$

Thus $OB^2 = 5^2 + 12^2 = 169$. Since $OB > 0$, then $OB = 13$.

ANSWER: (E)

2. 1966 Junior Mathematics Contest, Question 27

A man has walked two-thirds of the distance across a railroad bridge when he observes a train approaching at 45 kilometers per hour. If he can just manage to escape by running at the same uniform speed to either end of the bridge, what is this rate of speed?

Solution



In the diagram, the man runs from B to A , point M is $\frac{2}{3}$ of the way from B to A and point P is $\frac{1}{3}$ of the way from B to A .

The train is approaching A and the man sees the train when he is at M .

We are told that if the man runs towards A , he will arrive at A at the same time as the train.

Since $MA = MP$, then if the man runs towards B , when the train arrives at A , the man will be at P .

We are told that if the man runs towards B , he will arrive at B at the same time as the train.

Thus, the man runs from P to B in the same time as the train travels from A to B .

Since $PB = \frac{1}{3}AB$, then the man's speed is $\frac{1}{3}$ that of the train.

Since the speed of the train is 45 km/h, then the man's speed is 15 km/h.

3. 1984 Fermat Contest, Question 19

If $100^{25} - 25$ is expressed as an integer, the sum of its digits is

- (A) 219 (B) 444 (C) 432 (D) 453 (E) 435

Solution

Since $100^{25} = 10^{50}$, then $100^{25} = 1000\dots00$ (that is, 1 followed by 50 0's).

Thus, $100^{25} - 1 = 999\dots99$ (that is, 50 9's).

Thus, $100^{25} - 25 = (100^{25} - 1) - 24 = 999\dots9975$ (that is, 48 9's followed by 75).

The sum of the digits is $48 \times 9 + 7 + 5 = 444$.

ANSWER: (B)

4. 1967 Junior Mathematics Contest, Question 23

Two parallel lines intersect the x -axis cutting off a line segment of length 3. The same lines also cut off a segment of the y -axis of length 4. The perpendicular distance between the lines is

- (A) 5 (B) 2.5 (C) $\frac{7}{3}$ (D) $\frac{5}{12}$ (E) none of these

Solution

Sketching two such lines as depicted below, we can create a right-angled triangle, ABC .

Note that x is the perpendicular distance we want.

Also, $BC = 3$ and $AC = 4$ since they form parallelograms with the axes.

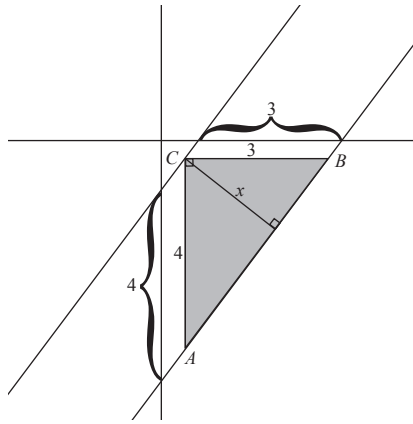

By the Pythagorean Theorem, $AB = \sqrt{BC^2 + AC^2} = \sqrt{3^2 + 4^2} = 5$.
 We obtain the triangle pictured below in two different orientations.

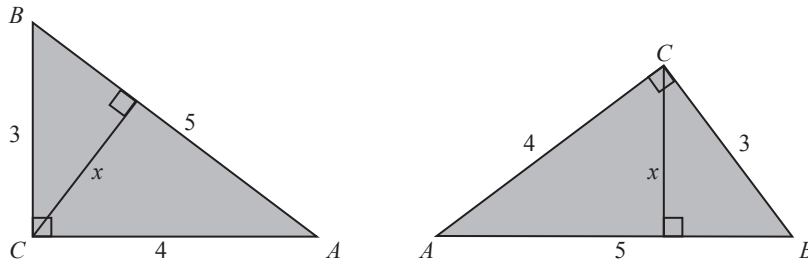

From the first orientation, the area of this triangle is $\frac{3 \times 4}{2} = 6$. From the second orientation, we can then say $6 = \frac{x \times 5}{2}$, as the perpendicular distance between the lines, x , is the height of the triangle in this orientation.

This yields $x = \frac{12}{5}$. Thus the perpendicular distance between the lines is $\frac{12}{5}$.

ANSWER: (E)

5. 1983 Cayley Contest, Question 15

In a competition, the average score of Pat's first 4 games was 6.5; the average of her next 5 games was 6.4. If she scored 9 on her tenth game, her overall average was

- (A) 10.95 (B) 7.725 (C) 7.3 (D) 6.96 (E) 6.7

Solution

When Pat scored an average of 6.5 points over 4 games, she scored a total of $6.5 \times 4 = 26$ points. When Pat scored an average of 6.4 points over 5 games, she scored a total of $6.4 \times 5 = 32$ points. Over her 10 games, she scored $26 + 32 + 9 = 67$ and so her overall average was $67 \div 10 = 6.7$.

ANSWER: (E)